

FM 55-60

**ARMY
TERMINAL
OPERATIONS**

HEADQUARTERS, DEPARTMENT OF THE ARMY

DISTRIBUTION RESTRICTION: Approved for public release; distribution is unlimited.

**ARMY TERMINAL
OPERATIONS**

TABLE OF CONTENTS

	Page
PREFACE	iv
CHAPTER 1. OVERVIEW	
Introduction	1-1
Types of Terminals	1-1
Classification of Terminals by Cargo Type	1-3
Special Operations	1-4
Command Organizations	1-4
CHAPTER 2. MARINE TERMINAL UNITS	
Introduction	2-1
Organization	2-1
Transportation Terminal Service Company (Container/Break-bulk) (TOE 55-827L)	2-2
Transportation Terminal Service Company (Break-bulk) (TOE 55-818L)	2-4
Transportation Cargo Transfer Company (TOE 55-817L)	2-6
Transportation Terminal Service Detachment (TOE 55-560L)	2-7
CHAPTER 3. MARINE TERMINAL OPERATIONS	
Introduction	3-1
Planning Phases	3-1
Management and Operation of Strategic, Common-User Contingency Seaports	3-2
Marine Terminal Planning Steps	3-6
Planning Considerations	3-6
Operational Planning	3-7
Ammunition and Hazardous and/or Classified Cargo	3-7
Terminal Capacity	3-8
Ship Destination Meeting	3-11
Vessel Unloading	3-12
Productivity	3-13
Cargo Clearance	3-10
Vessel Loading	3-14
Documentation	3-15
Floating Craft Maintenance	3-17

DISTRIBUTION RESTRICTION: Approved for public release; distribution is unlimited.

*This publication supersedes FM 55-60, 18 May 1987.

	Page
Personnel Movement	3-18
Communications	3-19
CHAPTER 4. LOGISTICS OVER-THE-SHORE OPERATIONS	
Introduction	4-1
Operation Planning	4-1
Reconnaissance and Site Selection	4-4
Beach Capacity	4-6
Beach Transfer Points	4-8
Temporary Holding Areas	4-8
Traffic Control	4-9
Beach Management	4-9
Unloading Operations	4-10
Shore-to-Shore Operations	4-10
CHAPTER 5. INLAND WATERWAY OPERATIONS	
Introduction	5-1
Inland Waterway System	5-1
Inland Waterway Terminal	5-2
Operational Planning	5-2
CHAPTER 6. MARSHALING YARD OPERATIONS	
Introduction	6-1
Organization and Functions	6-2
Surface Requirements	6-5
Location of the Container Marshaling Area	6-5
Stacking Configurations	6-6
Space Requirements	6-12
Terminal Activities	6-12
Marshaling for Rail Movement	6-13
Procedures	6-13
Security	6-27
CHAPTER 7. INLAND TERMINAL OPERATIONS	
Introduction	7-1
Staff and Unit Planning	7-2
Operational Planning	7-2
Personnel and Equipment Requirements	7-3
Air Terminals	7-4
Motor Transport Terminals	7-5
Rail Terminals	7-5
Inland Waterway Terminals	7-6
Personnel Movements	7-6
Documentation	7-6

PREFACE

This FM deals with Army terminal operations in a TO. It contains procedures and techniques to plan, use, and control Army water, motor, rail, and air terminal operations. It explains the transportation doctrine and organizational structures needed to deploy Army terminal operations in a TO. It covers roles, missions, and concepts of employment for terminal operation units.

This manual is mainly for unit commanders, key personnel, higher HQ staffs, theater planners, and commanders of operational allied units.

This publication implements the following international agreements:

- **STANAG 2166**, Movements and Transport Documents Used for Movements by Ship
- **QSTAG 592**, Forecast Movement Requirements—Rail, Road and Inland Waterways
- **STANAG 2926**, Procedures for the Use and Handling of Freight Containers for Military Supplies

The proponent of this publication is HQ TRADOC. Send comments and recommendations on DA Form 2028 (Recommended Changes to Publications and Blank Forms) to Commandant, US Army Transportation School, ATTN: ATSP-TDX, Fort Eustis, Virginia 23604-5389.

The US Army's environmental strategy into the 21st century defines the Army's leadership commitment and philosophy for meeting present and future environmental challenges. It provides a framework to ensure that environmental stewardship ethic governs all Army activities. The Army's environmental vision is to be a national leader in environmental and natural resource stewardship for present and future generations, as an integral part of all Army missions. The Army's environmental vision statement communicates the Army's commitment to the environment.

Unless this publication states otherwise, masculine nouns and pronouns do not refer exclusively to men

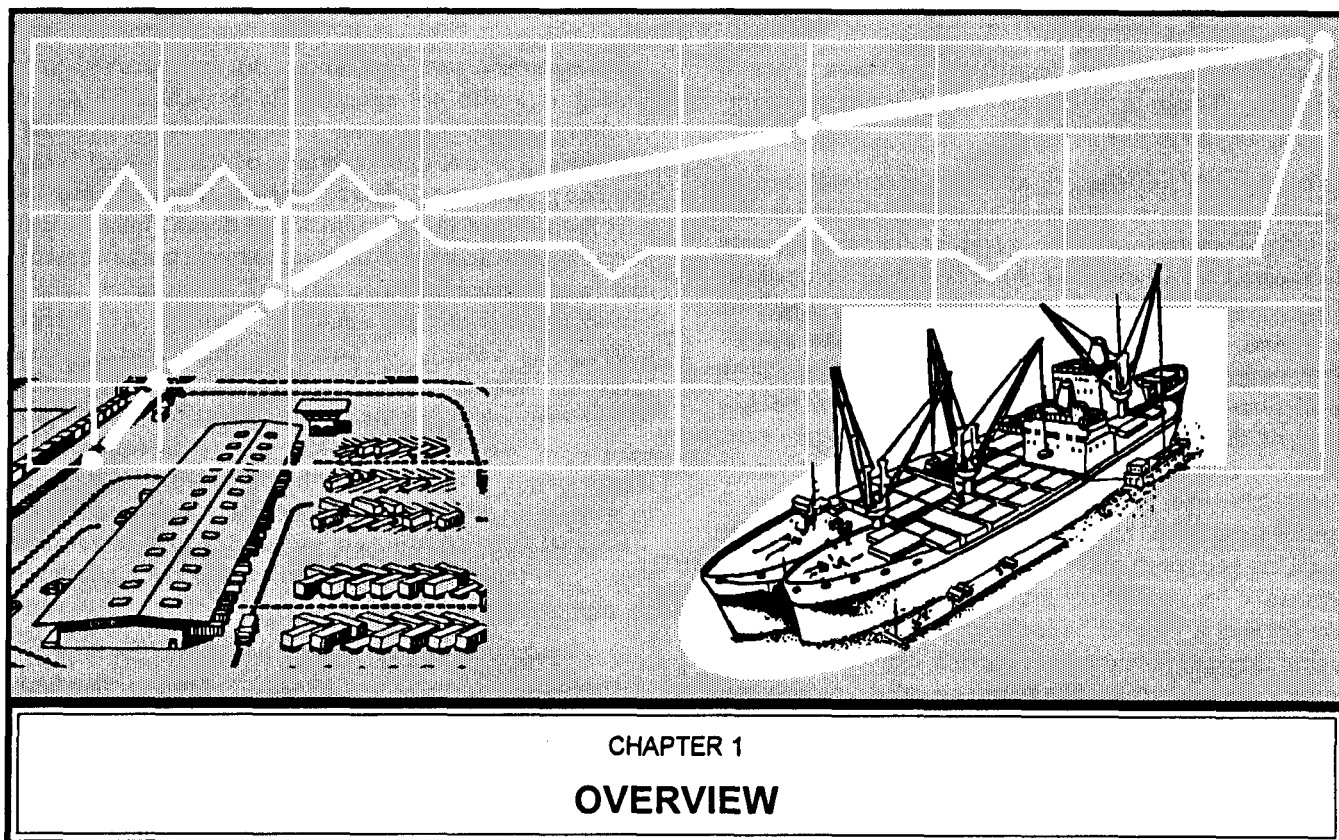

CHAPTER 1 OVERVIEW

INTRODUCTION

Terminals are key nodes in the total distribution system that support the commander's concept of operation at all levels of war and through the range of military operations. They provide loading, unloading, and handling of cargo and personnel between various transportation modes. When linked by modes of transport, they define the transportation structure for the operation. Force projection missions require early identification and establishment of terminals. A well-conceived plan assures that terminals can support the deployment, reception, and onward movement of the force and its sustainment. Crucial to the execution of the operation is the assignment of the right personnel, cargo, and material handling equipment at each terminal. ITV of material moving through the transportation system also provides the CINC with information pertaining to location and final destination of all cargo.

The Army is required to function across a range of operation from peacetime through conflict to war (see FM 100-5). Terminal operators must be able to operate in every TO. Terminals will be vulnerable to air and missile attacks, especially if US and allied forces have not established air superiority and sea control. They may also be subject to attacks by unconventional forces and to sabotage, terrorism, mining, espionage, and chemical or biological attacks. Whatever the level of the Army operation, terminals will remain a critical piece to ensure continuous movement of personnel and cargo.

TYPES OF TERMINALS

The two main categories of Army terminal operations consist of marine terminal operations and inland terminal operations. These are described below.

Marine Terminals

Marine terminals are classified into three types of facilities. These facilities include fixed-port, unimproved, and bare beach.

Fixed-port facilities. Fixed-port terminals are an improved network of cargo-handling facilities designed to transfer oceangoing freight. These terminals are located worldwide. At these facilities, deep-draft oceangoing vessels berth themselves along a pier or quay and discharge cargo directly onto the apron. Most cargo is moved into in-transit storage areas to await terminal clearance. Selected cargo may be discharged directly to land transport. The type, size, number, and location of military marine terminals selected for use, dictate the number and types of units needed to sustain theater support requirements. Using small or geographically dispersed terminals may be necessary for flexibility and survivability. However, this creates a greater need for command and control organizations. A fixed-port facility operated by a HN under contract, may only require a contract supervision team (TOE 55-560LC). A similar facility operated as a military marine terminal, may require a terminal battalion (TOE 55-816L). Fixed-port facilities are designed for oceangoing vessel discharge operations and port clearance. These facilities have sufficient water depth and pier length to accommodate deep-draft vessels. They also have highly sophisticated facilities, equipment, and organization to effectively support cargo discharge and port clearance operations.

Direct pierside discharge is used whenever possible because of its efficiency and fewer military resource requirements. It most effectively uses personnel and equipment. It is the most practical way to discharge large equipment and large volumes of containerized cargo. Its effectiveness depends on the inland transportation net's ability to clear discharge and cargo. Equipment needed for direct pierside discharge operations varies with the nature of the cargo and the type of vessel being worked.

Generally, TOE authorized to terminal service companies is sufficient to conduct general cargo operations (container and break-bulk). Since this type of operation handles large volumes of cargo and containers, careful planning is essential.

Unimproved port facilities. An unimproved port facility is a site not specifically designed for cargo discharge. It does not have the facilities, equipment, and infrastructure characteristic of a fixed-port facility. The predominant characteristics of an unimproved port facility are insufficient water depth, insufficient pier length to accommodate oceangoing cargo vessels, and inadequate clearance network. As a result, shallow-draft lighterage must be used to discharge oceangoing vessels anchored in the stream. Other facilities may be available, but they are generally inadequate for cargo discharge operations on a scale associated with a fixed port. In most instances, US Army terminal service units using equipment organic to their TOE, operate unimproved port facilities. These terminals are established or used when developed fixed-port facilities are not available or are inadequate to support the workload.

Bare beach facilities. A bare beach facility best fits the perceived definition of a LOTS operation. In a bare beach facility, Army lighterage is discharged across a beach. Normally no facilities, equipment, or infrastructure are available to support cargo loading, discharge, or port clearance operations. The terminal service and watercraft units must rely exclusively on equipment organic to their TOE or from engineer support units. Beach terminals require specifically selected sites where lighterage cargo is delivered to or across the beach and into marshaling yards or onto waiting clearance transportation. Landing craft, amphibians, and terminal units are used in a beach operation under the command and control of a terminal battalion. The same basic cargo-handling functions performed in a fixed port are the mission requirements at the beach terminal. However, beach operations are conducted under less than desirable conditions and usually require significant engineer support.

Inland Terminals

Inland terminals include the following types of terminals:

- Air.
- Motor transport.
- Inland waterway.
- Rail.

Inland terminals provide cargo transfer facilities at interchange points between air, rail, truck, and water transportation nets. They also provide these facilities from connecting links between these modes when terrain and operational requirements cause a change in carrier. Chapter 7 discusses inland terminal operations.

Marine terminals and inland terminals may be further identified by the type of cargo they are designed to handle. The Army also operates marine and inland POL terminals in cooperation with the QM corps. However, this manual does not address these operations. Figure 1-1 shows the types of terminals and their subclassifications.

**CLASSIFICATION OF TERMINALS
BY CARGO TYPE**

General Cargo Terminals

Large, covered, in-transit sheds on the pier with a working apron between the ship and in-transit sheds, characterize general cargo marine terminals. There may be one or several shore cranes. However, many general cargo terminals depend on self-sustaining cargo vessels to discharge most of the cargo. These terminals are best equipped to handle heavy lift or special lift cargo. General cargo terminals are found in developing countries where the volume of traffic or the lack of complex facilities prohibit the expansion of specialty terminals. Fixed ports, unimproved ports,

and bare beach sites can handle general cargo. They are identified as general cargo fixed ports, general cargo unimproved ports, or general cargo bare beach sites. General cargo terminals specialize in break-bulk operations where cargo is handled as individual pieces of freight such as pallets, boxes, or bales. These terminals can also discharge containers. However, the containers must be handled as a special lift, outsize, or heavy cargo. Container stacking and marshaling areas are normally small and MHE is inadequate for container handling; therefore, container productivity rates are not high.

Container Terminals

Container terminals are specialized facilities designed for uninterrupted, high-volume flow of containers between ship and inland transportation modes, and vice versa. Specialized, largely non-self-sustaining vessels that are unloaded by high productivity industrial equipment, service these terminals. These terminals may have facilities to consolidate break-bulk cargo into containers. An efficient container terminal equipped with gantry cranes can usually discharge and back-load a non-self-sustaining containership in 24 to 48 hours. In overseas areas, HN civilian personnel operate established container terminals during peacetime and are expected to continue to operate them during war. If the terminals are available, but the local civilian work force or the industrial facilities are not, an Army terminal service company (container/break-bulk) (TOE 55-827L) can operate the facility.

MARINE TERMINALS	INLAND TERMINALS	CARGO CLASSIFICATION OF TERMINALS
<ul style="list-style-type: none"> • FIXED-PORT FACILITY • UNIMPROVED PORT FACILITY • BARE BEACH FACILITY 	<ul style="list-style-type: none"> • AIR TERMINAL • MOTOR TRANSPORT TERMINAL • RAIL TERMINAL • INLAND WATERWAY TERMINAL 	<ul style="list-style-type: none"> • GENERAL • CONTAINER • RO/RO • COMBINATION (COMBI-TERMINAL)

Figure 1-1. Types of terminals and subclassifications

Although containers can be moved through an unimproved port or bare beach facility, productivity is adversely effected. When used alone, container terminal applies to a fixed-port facility specifically designed for container operations. Unimproved container port and bare beach container port only describe the predominant configuration of the cargo transiting those ports. Their names do not imply that the port is specially designed to handle containers.

RO/RO Terminals

A RO/RO terminal is another specialized facility designed to handle cargo on tracks or wheels. A RO/RO terminal consists of the following:

- Deepwater berth.
- Centralized management cluster.
- Terminal in- and/or out-processing facilities.
- Large, open controlled parking area.

The key element of the RO/RO terminal is that all cargo remains on wheels throughout the terminal transit cycle. Vessel turnaround times vary according to the size of the vessel and the quantity of cargo. Complete discharge and back-loading can normally be done in 18 to 36 hours. The productivity of RO/RO terminals depend on the cargo rolling off the ship, through the terminal and related processing, and onto final destination. RO/RO operations at an unimproved or bare beach facility are not as efficient as at a fixed-port operation. During fixed-port operations, vessels are discharged directly to land rather than to lighterage. A RO/RO terminal is a fixed-port terminal.

Combi-terminals

The combi-terminal provides a combination facility that can handle containers and conventional cargo in the same area. At pierside, such facilities frequently feature conventional cargo cranes (8 to 16 tons) and a large capacity (60-ton) container gantry crane. At landside, an overhead gantry crane services an open air container storage area with related equipment such as yard tractors and straddle carriers. Typically, extensive open-air and closed storage areas exist for general cargo operations. The combi-terminal's advantage is that both types of cargo can be handled efficiently at a single location without shifting the vessel from a container berth to a general cargo berth to discharge the vessel.

When dealing with terminal operations, transportation planners must carefully consider the cargo discharge capabilities of available facilities. Combi-terminals are ideal for Army terminal operations. However, if a combi-terminal is not available, planners must tailor the port support resources to meet terminal and cargo characteristics.

SPECIAL OPERATIONS

Amphibious, shore-to-shore, and riverine operations are special operations in which terminal operations play an integral part. They are not terminal operations in and of themselves. FM 55-50 has more information on amphibious, shore-to-shore, and riverine operations.

COMMAND ORGANIZATIONS

The command element in the COMMZ is the TA HQ. It provides an integrated support system for subordinate organizations. Its operational area extends from the marine terminals of the theater to the rear boundary of the corps. It thereby provides the necessary link between the combat force and its source of manpower and material replenishment. The TA is organized with four mission commands and a variable number of TAACOMs.

The TA commander is an organizer, supervisor, planner, and coordinator. He decentralizes authority for combat and CSS operations to his four subordinate functional commands (see Figure 1-2).

The TA TRANSCOM, one of the functional commands, supports TA requirements (see Figure 1-3). It may include groups, battalions, companies, and teams of the 55-series TOE. The TRANSCOM is the principal Army transportation HQ in the theater. Although located in the COMMZ, it provides theaterwide mode operations required to provide an integrated transportation system. The TRANSCOM provides for the movement of personnel replacements and supplies at shipside, at air terminals, or at rear area depots. It delivers them as far forward as possible toward the CZ while minimizing unloading, reprocessing, rehandling, or transshipping at intermediate points.

The senior terminal HQ under the TRANSCOM is a terminal group. It commands up to six terminal battalions based on the operation. The transportation terminal battalion is the basic operating HQ in the terminal structure. It commands each marine terminal in the theater.

Transportation Composite Group

The transportation composite group (TOE 55-622L) is normally responsible for all terminal operations within a specified area. When the size and complexity of the theater requires two or more transportation

composite groups, a TRANSCOM assumes responsibility for all theater terminal operations. The composite group, when subordinate to the TRANSCOM, is responsible for assigned terminal operations.

Mission and assignment. The HHC, transportation composite group, provides command and staff planning for units employed in transportation service activities that support an independent division-size force or a two-division size separate corps force. The group is normally assigned to a support brigade that supports an independent force.

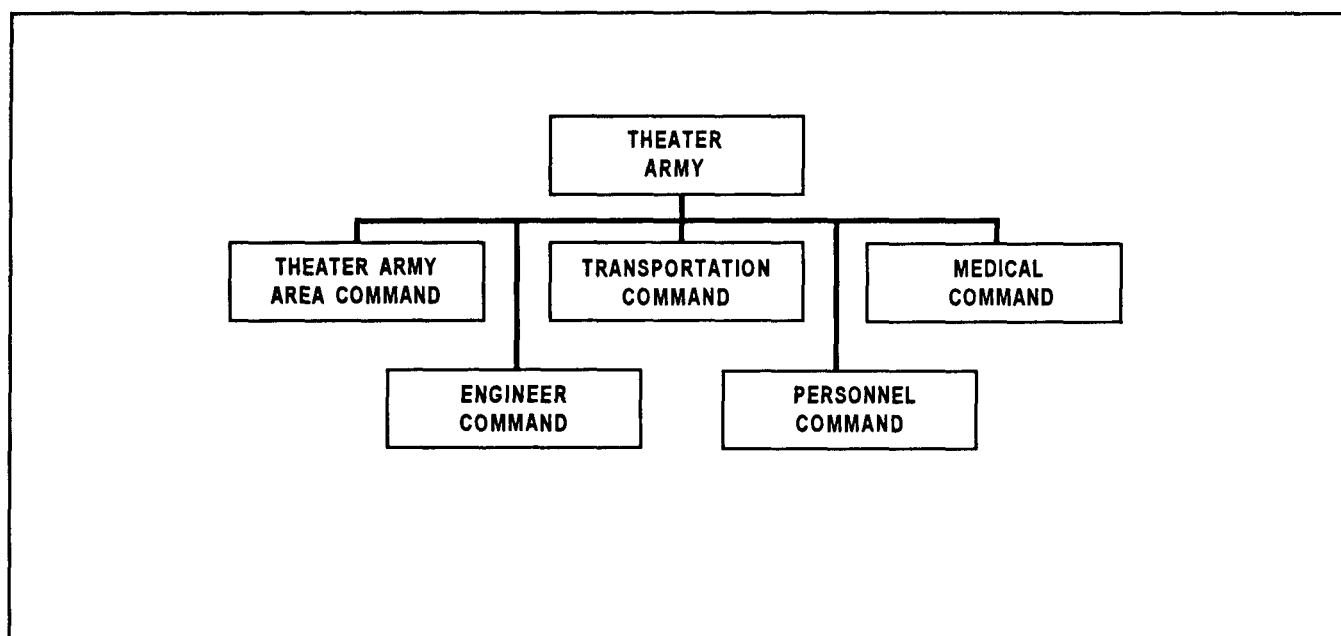

Figure 1-2. TA command organization

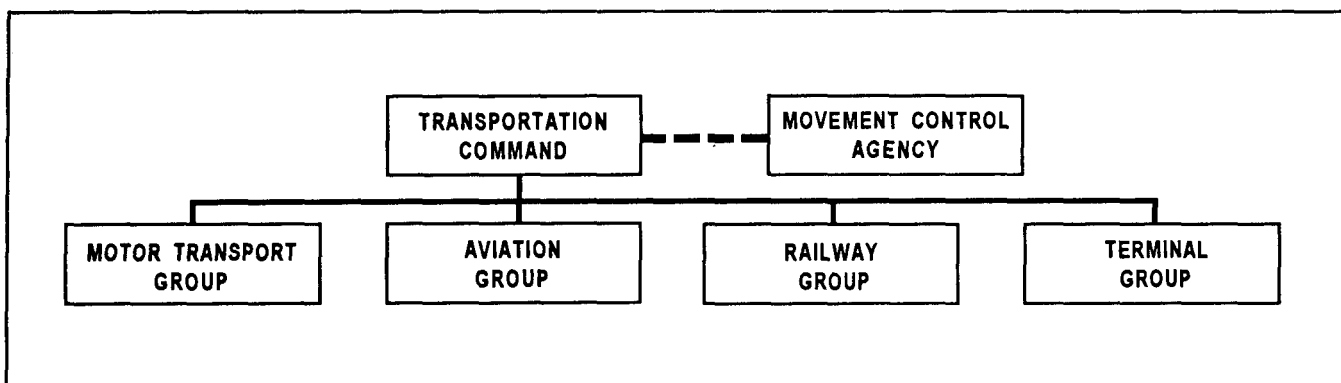

Figure 1-3. Transportation command organization

Capabilities. The transportation composite group can plan, control, and supervise the activities of attached air, motor, terminal service and/or cargo transfer, rail, and watercraft transportation units required to support an independent force. The transportation composite group also provides a nucleus organization for the development of a TRANSCOM during initial stages of a logistical base build-up. The group can command two to seven transportation battalions with a combination of units to support all or selected modes of transportation requirements.

Functions. The transportation composite group depends on appropriate functional commands of the TA for medical, signal, finance, legal, and personnel administrative services. The HHC, transportation composite group also does the following:

- Manages military and civilian personnel.
- Administers labor management policies with respect to non-US civilians and employees.
- Executes policies regarding non-US civilian labor and maintains coordination with appropriate civil affairs.
- Collects, processes, and disseminates intelligence information and supervises intelligence training and security and intelligence programs.
- Prepares SOPs, directives, and plans for installation and area security; and area damage control within assigned areas.
- Coordinates these plans with subordinate commanders and adjacent commands or activities.
- Prepares current and long-range plans, procedures, policies, and programs pertaining to operations and functions for all modes of transportation required to support the independent force or TO.
- Prepares SOPs, directives, and plans to interpret and implement environmental considerations IAW SOFA and US environmental regulations.
- Selects and allocates units by types and numbers required to support the mission of the transportation composite group.
- Inspects units, installations, and activities of subordinate commands.
- Assists subordinate units with training plans and programs. Monitors training activities of subordinate units.
- Develops plans to move personnel and cargo through the transportation mode terminals operated by subordinate units.

- Coordinates with the MCC to manage and clear all modes of transport operations supporting the force or theater.

- Develops requirements for communications and ADP systems service required to support operations of the group and subordinate units.

- Procures material and services locally, particularly contract services, to support operations of the multi-modal terminals and transport operations supporting the independent force or theater.

- Develops SOPs, directives, current and long-range plans, procedures, policies, and programs in the logistics areas pertaining to supply and maintenance programs and activities in subordinate units. Helps units obtain and coordinate support services with the responsible units or elements.

- Manages maintenance, to include developing appropriate policies, procedures, and operational instructions relative to maintenance and safety activities for subordinate units.

Transportation Terminal Battalion

The transportation terminal battalion (TOE 55-816L) is the basic command and control HQ for theater terminal operations. It is the normal command element for each two- to four-ship marine terminal. It is the key terminal organization supporting amphibious operations. It is also the command element in inland waterway operations (see Chapter 5).

The terminal battalion is a flexible organization. Its components vary according to the particular requirements of each of its diversified missions. Tailoring is done by modifying the number and types of units attached for each task. In addition to the terminal-type units, transportation truck companies and certain nontransport units may be attached to the terminal battalion to meet specialized mission requirements.

Mission and assignment. The HHC, transportation terminal battalion commands units operating marine terminals. The transportation terminal battalion is assigned to the TRANSCOM. It is normally attached to a transportation terminal group or a transportation composite group. It may also operate separately under the supervision of a TRANSCOM.

Capabilities. The transportation terminal battalion can command two to seven transportation terminal-type units. These include terminal service, terminal

transfer, boat, amphibian, or harborcraft. It can command the equivalent of a four-ship terminal in an established port facility or a two-ship terminal in a beach operation.

This unit depends on the personnel service company (TOE 12-467L) for personnel administration. It depends on area medical services for unit level medical support. It also depends on appropriate teams from the finance corps (TOE 14-403L) for finance services.

Functions. The HHC, transportation terminal battalion functions are as follows:

- Commands units conducting marine terminal operations.
- Operationally controls loading, unloading, and cargo transfer operations.
- Supervises documentation activities of the battalion and maintenance of ship's files.
- Determines the estimated workload and transportation. Ensures that necessary transport equipment is available.
- Assists and advises subordinate operating units concerning identification, segregation, and documentation of cargo, either aboard ship *or* on shore.
- Ensures subordinate units operate IAW appropriate federal, state, local, and HN environmental laws.

- Consolidates requisitions and procures supplies and equipment for subordinate units.

- Conducts maintenance inspections of vehicles and equipment.

- Exercises staff supervision overall maintenance, supply, equipment, evacuation, real estate, safety policies, environmental policies, and food service activities of the battalion.

- Provides wire communications and message center service for communication with higher HQ and with subordinate units of the battalion.

- In the absence of a transportation contract supervision team (TOE 55-560LC), supervises contracting operations supporting terminal operations.

- Reviews intelligence data to assess impact on operations and to allow defensive measures.

The HQ company of the transportation terminal battalion may consolidate some of the functions of subordinate units, such as MHE operations and documentation. Consolidated operations, under some circumstances, provide better allocation, management, and control of scarce skills and resources.

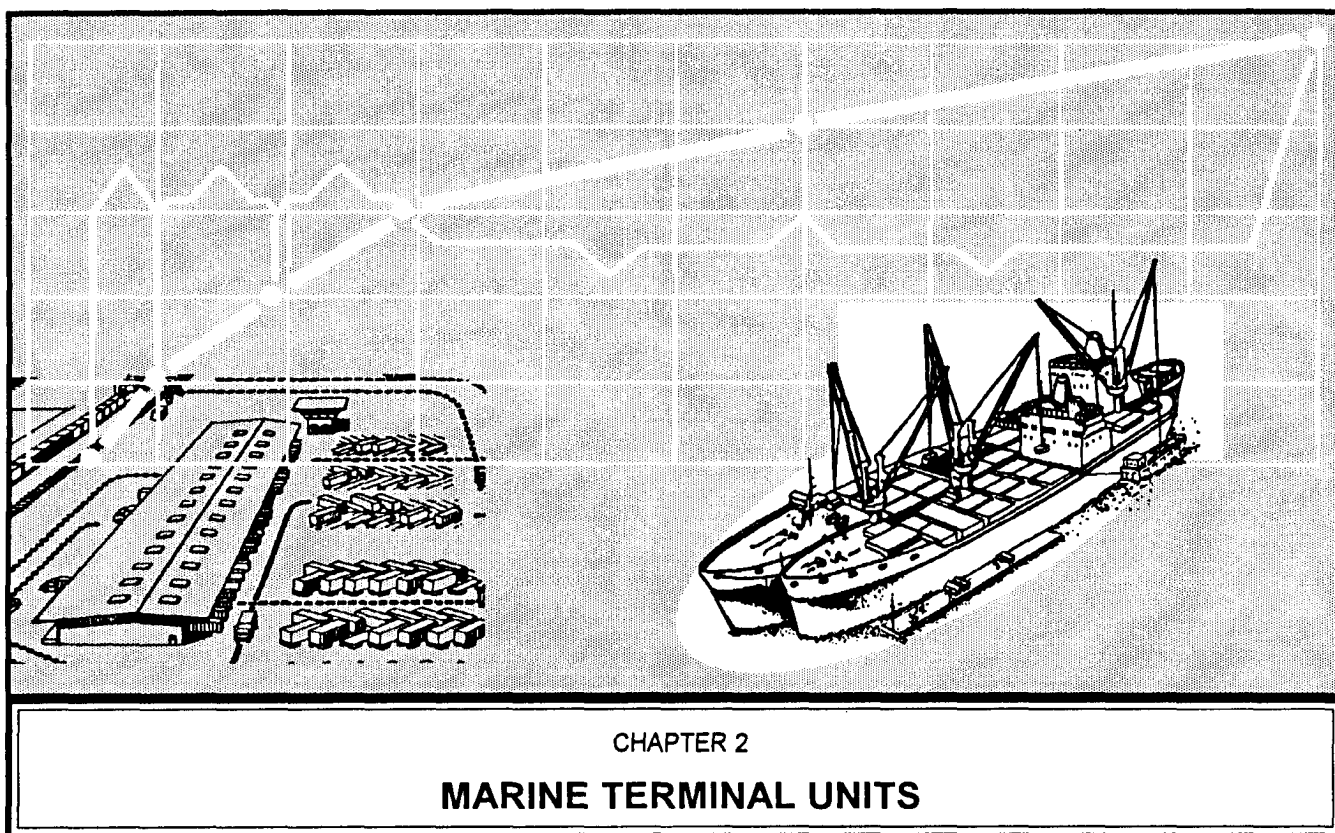

INTRODUCTION

Marine terminal units work closely with marine transport units. The US Army currently has three major types of marine transport units. These are the transportation medium watercraft company (TOE 55-828L), the transportation heavy watercraft company (TOE 55-829L), and the medium lighter company (ACV) (TOE 55-833 L). There are also 18 separate TOE teams designed to perform specific marine CSS functions where units of less than company size are appropriate. Amphibians and boat companies move cargo and personnel from ship to shore. The amphibians can move cargo directly to inland transfer points, thus reducing beach and cargo handling. Cellular teams identified in TOE 55-530 provide harborcraft. Harborcraft include tugs; barges; and floating cranes; and command and control boats which are essential to the command and control, of marine terminal operations in fixed ports or LOTS operations. See FM 55-50 for more information on Army marine transport operations.

ORGANIZATION

The marine terminal organization (see Figure 2-1, page 2-2) consists of terminal service, harborcraft, lighterage companies, and the command units needed to supervise and coordinate their operations. The size and composition of the marine terminal organization depends on variables such as the number of ports and beaches to be used, the quantity of cargo and number of personnel to be moved through the terminals, and the capabilities and availability of local resources and facilities. As the basic operating HQ in the theater terminal structure, the terminal battalion provides direct command and control over the terminal service companies. It also provides operational supervision over the terminal service companies and the amphibian and boat units that deliver cargo to and through the beach.

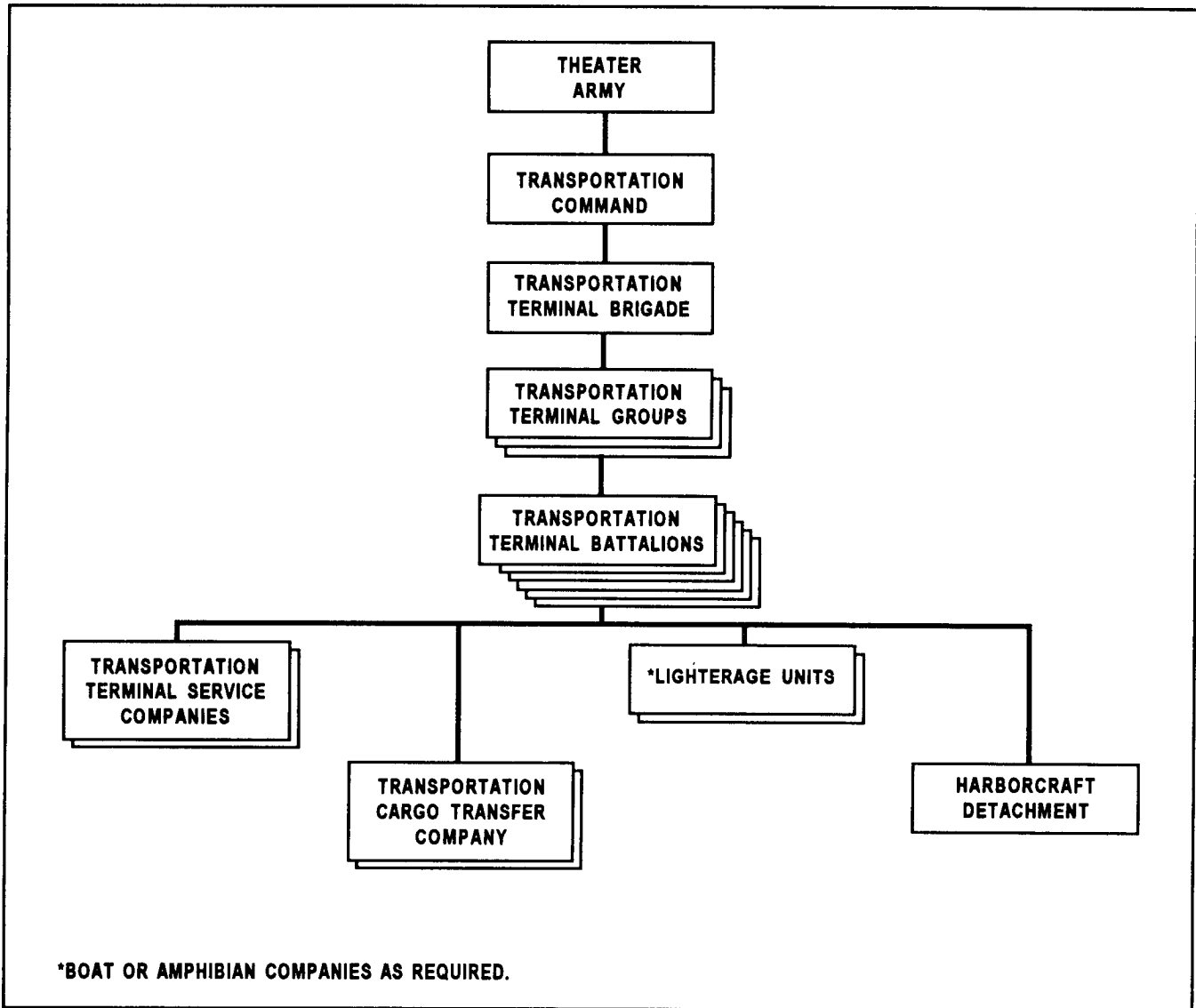

Figure 2-1. Marine terminal organization

**TRANSPORTATION TERMINAL SERVICE COMPANY
(CONTAINER/BREAK-BULK) (TOE 55-827L)**

The transportation terminal service company (container/break-bulk) (TOE 55-827L) is designed to discharge, back-load, and transship break-bulk and containerized cargo at marine terminals located at fixed ports, inland barge terminals, or in LOTS operations. This unit is designed to simultaneously work break-bulk and container vessels at fixed terminals or in a LOTS operation.

The container/break-bulk terminal service company can operate independently or its operations may be integrated with those of other marine terminal units supervised by the same battalion. Centralization of equipment, maintenance, and documentation at the battalion level is also feasible within the obvious constraints imposed by container-peculiar equipment and equipment operators.

The container/break-bulk terminal service company requires external support services identical to those provided to the break-bulk terminal service company. Responsibilities for cargo discharge operations parallel those of break-bulk terminal service units as they pertain to discharging, back-loading, transshipping, and related functions. The essential difference between the two organizations is the size and weight of the individual package being moved. For a break-bulk company, a container is a special lift (oversize/overweight). For a container/break-bulk unit, the container is a normal lift; the unit has trained personnel and the equipment necessary to routinely handle containers.

Mission and Assignment

The mission of the transportation terminal service company (container/break-bulk) is to discharge, back-load, and transship break-bulk and containerized cargo at marine terminals located at fixed ports or in LOTS operations.

The terminal service company (container/break-bulk) can be assigned to a TRANSCOM or to a transportation terminal group. When supporting an independent force, it is normally assigned to a COSCOM, support brigade, or transportation composite group. A terminal battalion normally commands and controls this attached unit.

Capabilities

At Level 1, on a two-shift basis with 75 percent operational availability of all mission equipment, this unit can perform numerous missions. In a LOTS operation, this unit can simultaneously do the following:

- Discharge or back-load 300 containers or discharge and back-load 100 containers when supported by a heavy crane platoon, TOE 55-560LE.

- Discharge or back-load 1,600 STONs of break-bulk cargo or discharge 800 STONs of break-bulk cargo and back-load 800 STONs.

- Sort break-bulk and containers by designation, load break-bulk cargo and containers from the marshaling yards on land transportation, and perform limited stuffing and unstuffing of containers.

- Receive and process containers for retrograde.

- Provide limited in-transit storage.

Infix-port operations, this unit can simultaneously do the following:

- Discharge or back-load 600 containers or discharge and back-load 200 containers, when supported by a heavy crane platoon, TOE 55-560 LE.

- Discharge or back-load 2,500 STONs of break-bulk cargo or discharge 1,250 STONs of break-bulk cargo and back-load 1,250 STONs.

This unit can sort break-bulk and containers by designation, load break-bulk cargo and containers from the marshaling yards on land transportation, and perform limited stuffing and unstuffing of containers. It can receive and process containers for retrograde. It can also provide limited in-transit storage.

Type B and Level 1 organizations have the same capabilities. The Type B column adapts this TOE to the lesser requirements for US military personnel. Vacancies existing in the Type B column indicate the types of positions that can be filled by non-US personnel. The number of non-US personnel, determined by the major commander, depends on the capacity of available personnel to produce, the number of shifts, and other local conditions.

Appropriate teams available to the theater commander provide interpreters and translators required when organized under the Type B column. The columns designated by Levels 1 through 3 are designed to relate to the categories established in AR 220-1. Individuals of this organization can help coordinate the defense of the unit's area or installation. This unit performs unit maintenance on organic equipment except C-E equipment. This unit depends on the following:

- The appropriate elements in the COMMZ and/or independent corps for health services, legal, finance, and personnel and administrative services.

- HHC, transportation terminal battalion (TOE 55-816L) or other appropriate HQ to which attached for unit maintenance of organic C-E equipment and religious services.

- Appropriate engineer units to provide port, LOTS, and POL facilities.

- The automated cargo documentation (TOE 55-560J2J) for cargo accounting and documentation.

- The heavy crane platoon (TOE 55-560LE) for container discharge support.

Basis of allocation is as required based on the stated capabilities. This unit is designated as a Category III unit. (For unit categories, see AR 310-25.)

Organization and Functions

The transportation terminal service company (container/break-bulk) consists of a company HQ, an

equipment maintenance section, two ship platoons with five hatch sections each, and two shore platoons with a clearance and yard section each.

The ship platoons are designed so that each platoon works a shift. The five hatch sections in each platoon are designed to work break-bulk or container cargo. The ship platoons can work break-bulk and container cargo operations simultaneously. These hatch sections are designed to work break-bulk container vessels. They can also work with the TACS to load or discharge container vessels having no onboard crane capability at piers or in LOTS operations. This unit has the organic equipment to sustain normal operations. It is normally augmented with a heavy crane platoon (TOE 55-560LE) to assist the shore platoon in clearance and marshaling yard operations. This augmentation is essential to increase productivity and discharge lighters in LOTS operations.

The two shore platoons work in shifts. Each platoon works a shift and each has a clearance section and a yard section. The shore platoon receives the break-bulk cargo or containers at water's edge, pierside, or on the beach. The cargo is then cleared to a marshaling or storage area or loaded directly on conveyances that will transport it to the next terminal or destination. The shore platoons also receive break-bulk cargo or containers for water shipment and must unload it on the pier or beach to be loaded aboard vessels or lighters. Shore platoons also consolidate cargo and stuff or unstuff containers. The shore platoons must also receive and process containers for retrograde shipments. They usually have a limited capability for in-transit storage.

There is no documentation platoon or section in this unit. The automated cargo documentation detachment (TOE 55-560LD) augments the unit for cargo accounting and documentation.

The equipment maintenance section stores, accounts for, and performs organizational maintenance on cargo-handling equipment, gear, MHE, and other TOE authorized hardware. It also performs limited emergency repair of containers. This repair is limited to the capability of assigned maintenance personnel. It is usually restricted to the repair of such items as sheet metal panels, door assemblies, and landing gear when

the damage prevents transport of the container. Although not specifically designed for two-shift operation, this section is normally required to work around the clock.

TRANSPORTATION TERMINAL SERVICE COMPANY (BREAK-BULK) (TOE 55-818L)

Found primarily in the RC, the transportation terminal service company (break-bulk) (TOE 55-818L) works in theater marine terminal operations to handle break-bulk cargo. It is organized to work a single ship on a two-shift, around-the-clock basis.

The transportation terminal service company (break-bulk) may operate separately, or its operations may be integrated with those of one or more other terminal service and lighterage units supervised by the same battalion. When time, space, and tactical conditions permit, it is generally more economical for a terminal battalion to operate centralized equipment pools, maintenance shops, and documentation centers. Under these circumstances, the battalion controls the equipment, the maintenance personnel, and the documentation clerks of the companies. This relieves the company commander of the responsibility for all functions except handling cargo. This includes discharging from ship to pier or lighter and loading cargo aboard clearance transport or moving it to a temporary holding or marshaling area. However, when operating separately, the company must analyze proposed operations against available equipment and notify the terminal battalion or group of any additional support needed. It must also prepare all documentation needed to forward the cargo to its initial destination (depot or user).

Higher HQ provides or arranges for external support services such as utilities, finance, legal, supply, medical, and maintenance support. The terminal service company (break-bulk) loads or discharges cargo, prepares cargo documentation, and places cargo aboard the clearance mode. Depending on the operational situation, cargo may be placed into in-transit storage areas before loading on clearance modes. Their respective battalion HQ arranges rail and motor transport clearance on a mission basis through movement control channels.

Organization and Functions

This transportation terminal service company consists of a company HQ, two ship platoons, two shore platoons, a documentation platoon, and a stevedore gear and equipment maintenance section. The company HQ consists of a commander and administrative and supply personnel.

Each ship platoon is designed to work one standard five-hatch ship. Each platoon consists of five 14-man hatch sections. In a normal 24-hour day, each platoon works one shift. In discharge operations, the ship platoon breaks the cargo out of the hold, lifts it over the side, and lands it on the wharf or into lighters. During loading, the ship platoon receives cargo at shipside, lifts it into the ship, and stows it in the hold. Each hatch section includes a hatch foreman, an assistant hatch foreman, a signalman, two winch operators, a forklift operator, and eight cargo handling specialists.

The hatch foreman oversees the loading and/or unloading of his assigned hatch. He is usually stationed on deck where he can observe the entire operation. He selects and obtains the proper type of cargo-handling gear and equipment and assigns tasks to section personnel during each operation. He supervises the positioning and rigging of booms, save-all, and cargo nets. He also observes and enforces safety regulations.

The assistant hatch foreman personally directs and supervises the cargo handling specialists working in the hold. He directs the stowing, bracing, and lashing or the breakout of cargo and enforces safety regulations. Depending on the type of cargo and operational requirements, the eight terminal operation specialists work in the hold, in teams, or divided between the hold and the pier or lighters being loaded or discharged. The assistant hatch foreman supervises their work.

On most ships, while operating the winches, the winch operators cannot see the cargo hook after it passes into the hold or over the side of the ship. A signalman is positioned so that he can see the draft of cargo at all times. He ensures that the winch operators can clearly see his signals. Standard signals for winch operators are in FM 55-17. Modern cargo-handling methods use winches, cranes, and side- or stern-loading ports, or any combination of these methods to load or discharge cargo.

The shore platoons provide the MHE and personnel to load and unload cargo on the wharf or at the beach. Each platoon consists of a HQ and a cargo-handling section. Each platoon is manned for a one-shift operation. A section chief who supervises the cargo handling specialists heads each cargo-handling section. MHE operators and truck drivers are assigned to both sections. The equipment of each section is pooled and operated around the clock. The unit is authorized rough terrain cranes and forklift trucks to handle cargo on the wharf or at the beach. The cargo handling specialists move cargo to and from the ship's gear and into and from clearance and incoming transportation. They also help in handling cargo moved within the terminal and temporary holding areas.

The documentation detachment accounts for all cargo the company handles and prepares all transportation documentation required to move cargo within the terminal. The detachment consists of a HQ, a documentation section, and a cargo-checking section. Each section is manned for two-shift operations. The cargo-checking section documents all cargo at shipside. This section tallies each item as it is loaded or unloaded and ensures that it is properly marked and documented. Documentation personnel may use automated devices to perform cargo accounting. These consist of handheld data input devices, CRTs tied into a mainframe, or stand-alone computers that require courier service to transfer information discs or tapes to the battalion or group. Two checkers are assigned to check cargo into or out of each hatch: one in the hold and one on the pier at the point of discharge. The 14 clerks in the documentation section are normally pooled with clerks of other terminal service companies in a battalion-operated documentation center. When the terminal service company is operating separately, the documentation section works directly with its parent unit in two shifts of seven personnel each.

The stevedore gear and equipment maintenance section stores, accounts for, and performs organizational maintenance on cargo-handling equipment, gear, MHE, and other TOE authorized hardware. Although not specifically designed for two-shift operations (duplication of skills), the platoon normally works around the clock. The engineer equipment repair technician

in charge must assign his personnel to shifts according to the amount and type of maintenance to be performed.

A number of functions normally performed in marine terminal cargo operations have no TOE positions provided for them. These include the operation of a dunnage yard, warehousing functions incidental to in-transit and security storage, and light engineering within the capabilities of the assigned engineer equipment. Manning for these functions must be arranged as needed from the available TOE personnel.

The terminal service company commander should be aware of the need for physical security to prevent pilferage and mishandling of government cargo. He must also be aware of the basic rules and guidance for all aspects of defense pertaining to the rear battle area.

The company commander must maintain a spill contingency plan including emergency supplies and equipment for isolating and disposing of hazardous material spills IAW federal, state, local, and HN environmental laws.

Mission and Assignment

The transportation terminal service company (break-bulk) discharges, back-loads, and transships break-bulk cargo at conventional marine terminals and in LOTS operations. The break-bulk terminal service company is normally assigned to the senior transportation command in the theater and is further attached to a transportation terminal battalion for command and control.

Capabilities

At full strength, this transportation terminal service company can operate on one ship, on a two-shift basis; or on two ships, on a one-shift basis at piers or over beaches with 75 percent equipment available. In a LOTS operation, this unit can do the following:

- Discharge or back-load 1,600 STONs of break-bulk cargo or simultaneously discharge 800 STONs of break-bulk cargo and back-load 800 STONs.
- Sort break-bulk by destination.
- Load break-bulk cargo from the marshaling yards on land transportation.

In LOTS operations, the weather and sea conditions on the supporting lighterage unit may reduce productivity significantly. Factors that reduce the overall tonnage potential of these units over extended periods, must be considered in planning for specific operations.

In a fixed-port operation, this unit can do the following:

- Discharge or back-load 2,500 STONs of break-bulk cargo or simultaneously discharge 1,250 STONs of break-bulk cargo and back-load 1,250 STONs.
- Sort break-bulk by destination.
- Load break-bulk cargo from the marshaling yards on land transportation.

TRANSPORTATION CARGO TRANSFER COMPANY (TOE 55-817L)

The transportation cargo transfer company (TOE 55-817L) will transship cargo at air, rail, and motor terminals. FM 55-12 outlines these responsibilities. This company can operate up to three separate terminals on an around-the-clock basis.

The transportation cargo transfer company (TOE 55-817L100/200) can transship cargo at Army air, rail, and motor terminals. The company can perform all functions associated with transshipment including unloading, discharging, cargo segregation and/or consolidation, cooperating, documentation, and loading. The unit has limited capability for temporary holding and stuffing and unstuffing containers. The cargo transfer company or its elements may also be used at Air Force air terminals to operate in-transit cargo areas to operate a small shipment consolidation point for retrograde cargo, or to function as an A/DACG.

Mission and Assignment

The transportation cargo transfer company is normally assigned to a TAACOM or to a COSCOM and attached to a transportation composite group, or as directed by the TA DCSLOG. It may be placed under the OPCON of the TAACOM on a temporary basis. It does not normally operate at distribution

points. However, the company or its elements may be committed to temporarily support supply units at distribution points if excessive cargo backlog or similar conditions create a need. The Army may establish facilities and station personnel at Air Force air terminals to perform functions pertaining to Army traffic. The cargo transfer company at or near the air terminals may operate an in-transit cargo area for large air shipments. Consolidated shipments consigned to multiple consignees are turned over to the cargo transfer company for unstuffing. It is then expeditiously delivered to consignees. Similarly, overseas theater units ship retrograde cargo to the in-transit area. The cargo transfer company consolidates shipments by commodity and by the destination depot in the CONUS to the greatest extent possible. These consolidated shipments are forwarded to the intertheater air terminal as directed by the appropriate Army movement control element. The transportation cargo transfer company may also help stage units taking part in airborne operations. It may help clear cargo backlogs in marine or air terminals. It may also perform functions as an A/DACG. This unit depends on the personnel service company for personnel services and on appropriate teams from the finance service organization for finance services. Appropriate hospital or area unit medical and support teams provide unit level medical support on an area basis. The brigade or group HHC to which the unit is attached or assigned provides chaplain support.

Capabilities

The transportation cargo transfer company (TOE 55-817L) is documented and organized in the following two variations:

□ When organized under TOE 55-817L100, with 75 percent of its mission vehicles and MHE operational, this unit can operate a single terminal on a 24-hour basis. It can transship or handle 1,000 STONs of break-bulk cargo or 150 containers daily.

□ When organized under TOE 55-817L200, with 75 percent of its mission vehicles and MHE operational, this unit can operate up to three separate terminals on a 24-hour basis. Each terminal can transship 1,000 STONs of break-bulk cargo or 150 containers per day for a unit total of 3,000 STONs of break-bulk cargo or 450 containers daily, or some combination thereof.

Organization and Functions

The company is organized and equipped to transfer cargo at all types of Army inland terminals, except large inland waterway terminals serving ocean-type shipping. It consists of a company HQ, an equipment maintenance section, and one to three cargo transfer platoons, depending on the variation of TOE 55-817L under which it is organized. Each platoon contains a platoon HQ, a cargo equipment squad, and two cargo operation sections. This structure includes personnel to process and prepare documentation for all cargo handled. This unit also has personnel, tools, and equipment to perform organizational maintenance on all unit equipment.

The transportation cargo transfer company in the L100 or L200 variation is equipped with 20-ton cranes, 140-ton container-handling cranes, 4,000- and 10,000-pound rough terrain forklifts, 50,000-pound container-handling rough terrain forklifts, and tophandler attachments for 20-, 35-, and 40-foot containers. The unit also has hand trucks, roller conveyors, cargo trucks, semitrailer and tractor combinations, shuttle tractors (yard dogs), and other cargo-handling gear and equipment necessary to perform the mission.

The L100 organization has only one cargo transfer platoon and is primarily employed when one terminal operation or reduced capability is required for an extended period. The L200 organization is normally employed with each of its three cargo transfer platoons assigned to work at a separate terminal. When elements of less than platoon size are needed, this requirement can be met by detailing a cargo transfer squad or element of one of the cargo operations sections and the necessary equipment to other terminals or locations for short periods. The company HQ or platoon should be located where it can best communicate and control operations.

TRANSPORTATION TERMINAL SERVICE DETACHMENT (TOE 55-560L)

These detachments can be used, as required, to augment terminal service and cargo transfer units. They are normally attached to a transportation terminal battalion or, in the case of the transportation contract supervision detachment (TOE 55-560LC), to a transportation composite group or a TRANSCOM.

**Detachment A
(Cargo Documentation)
(TOE 55-560 LA)**

This detachment documents cargo or containers being loaded, discharged, or transferred from one mode of transportation to another. It can complete documentation associated with loading and discharging 500 STONs of general cargo or 480 containers daily at marine terminals, railheads, truckheads, or airheads.

**Detachment B
(Freight Consolidation and Distribution)
(TOE 55-560LB)**

This detachment operates a consolidation and distribution point or terminal facility handling LCL (or truckload) lots of cargo. It can process 100 LCL shipments daily at a C&D point, fixed marine terminal, barge site, railhead, airhead, or truckhead. It can also stuff and unstuff 25 twenty-foot container equivalents daily.

**Detachment C
(Transportation Contract Supervision)
(TOE 55-560LC)**

This detachment negotiates for and administers contracts for stevedoring and inland waterway and highway transport. It contractually arranges for

loading or discharging of cargo from ships or barges and clearance of discharge cargo from the terminal. It contractually arranges for movement of cargo from terminals, depots, or local procurement sources by inland waterways and highway transport. It administers contracts connected with loading, discharging, and transporting cargo and the terminal clearance of that cargo.

**Detachment D
(Automated Cargo Documentation)
(TOE 55-560LD)**

This detachment, on a two-shift basis, documents break-bulk or container cargo. It can handle up to four ships in fixed-port operations or two ships in LOTS operations.

**Detachment E
(Heavy Crane Platoon)
(TOE 55-560LE)**

This detachment, on a two-shift basis, provides personnel and equipment to handle 400 containers in fixed-port operations and 200 containers from lighters in LOTS operations.

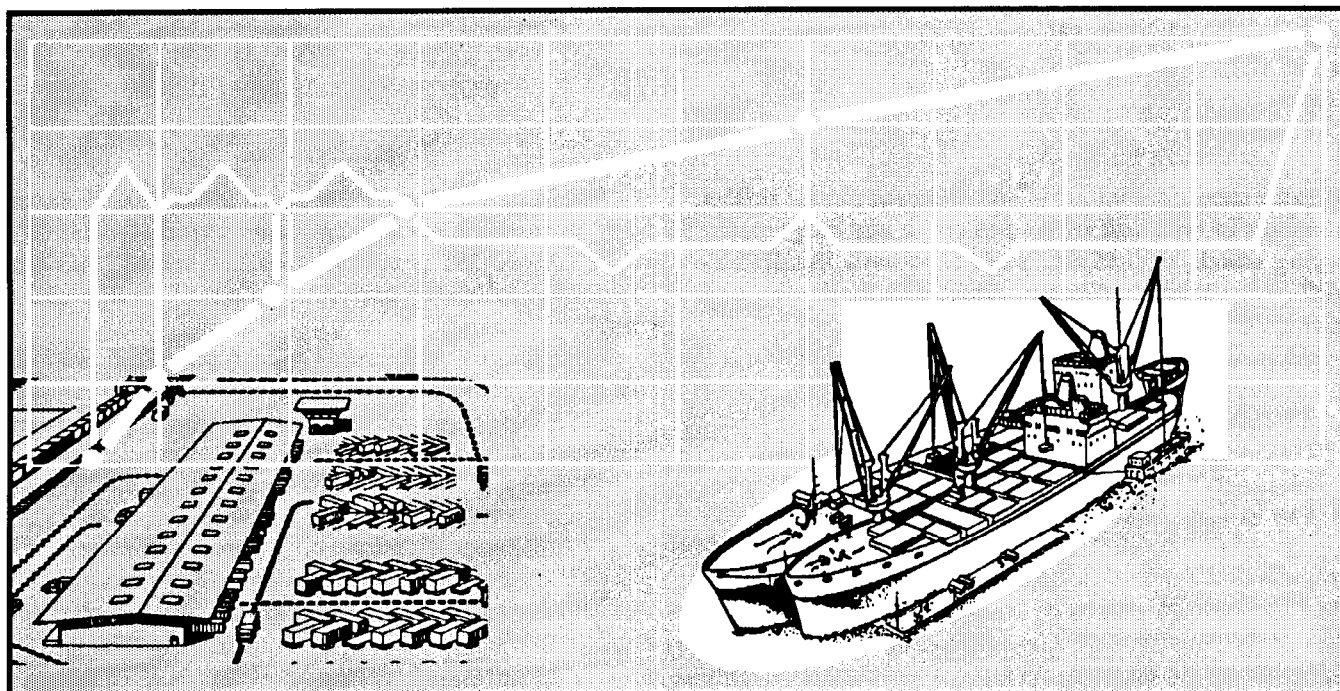

CHAPTER 3

MARINE TERMINAL OPERATIONS

This chapter implements STANAG 2166.

INTRODUCTION

The purpose of water terminal operations is to place equipment and supplies where and when needed. History has proven that 90 to 95 percent of unit equipment and sustainment cargo moves by SEALIFT and through marine terminals. This flow of cargo requires coordination between the strategic and operational level of war transportation organizations. Army logisticians must plan and coordinate the movement of this cargo from CONUS (SPOE) to the final destination in the theater (SPOD).

To assure the success of the operation, the terminal operators, as well as other agencies, will arrive in theater early to begin the discharge of arriving ships. It will be vital that the terminal units have the required MHE and personnel to conduct ship discharge

operations. Planners should establish terminals capable of handling palletized, containerized, bulk liquid, and RO/RO cargo. Problem areas must be identified and solutions reached either by direct coordination with the mode operators and receivers through command channels. Refer to FM 55-50 for more information on water terminals operations.

PLANNING PHASES

MTMC and MSC, based on availability, select the types and numbers of vessels used to support a TO. Vessel selection is based on the anticipated availability of marine terminals and the three phases of ship's planning. These phases are also important to the

MANAGEMENT AND OPERATION OF STRATEGIC, COMMON-USER CONTINGENCY SEAPORTS

Background

theater terminal planners. The different phases reflect changes in type and volume of cargo and cargo packaging which, in turn, are more efficiently handled by different varieties of vessel types. The three planning phases consists of the following:

- Initial phase.
- Tactical resupply phase.
- Sustained resupply phase.

Initial Phase

The initial phase introduces unit equipment. It depends greatly on the capability of discharging RO/RO vessels and barge-carrying vessels (LASH/SEABEE). In this phase, the military terminal organization is in the early development stages. It cannot fully handle large numbers of ships and large volumes of cargo. Ocean freight consists mostly of unit moves that require unit integrity of personnel, supplies, and equipment. RO/RO vessels and barge-carrying ships are desirable because of the high volume of vehicles being transported and the need to expedite vessel discharge and port clearance.

Tactical Resupply Phase

The tactical resupply phase addresses the time when terminal facilities are being operated and improved. Neither they nor the land transportation net can handle large volumes of containers discharged from non-self-sustaining containerships. Conventional break-bulk vessels and self-sustaining containerships off-load at fixed ports and through LOTS environments. The level of unit moves has dropped greatly. Accordingly, the percentage of vehicles in freight is reduced.

Sustained Resupply Phase

The sustained resupply phase occurs when the receiving ports and the theater transportation net can receive large volumes of containers discharged from large, non-self-sustaining containerships. The terminal organization is well developed. However, the availability of fixed facilities and the quantity and types of vessels affect port capacity. Maximum capacity is afforded by matching vessels to appropriate terminals.

The MTMC is generally considered DOD's expert on seaport operations and capabilities. A USTRANSCOM component command, MTMC performs the following activities on a routine or ongoing basis:

- Manages and operates 10 CONUS and 15 OCONUS common-user seaports.
- Opens, manages, and operates contingency ports supporting military exercises.
- Books DOD cargo with commercial carriers.
- Contracts for terminal services.
- Interfaces with HNs on port-related issues.
- Prepares ship manifests and other documents.
- Develops and operates seaport management systems.

□ Conducts surveys of seaport capabilities throughout the world.

Despite this acknowledged expertise in port management, theater CINCs do not always call on MTMC to assist in planning SPOD operations. MTMC's supporting role in implementing these plans may be inconsistent or ill-defined. Lacking specific doctrine and CAAs, theater port management has been arranged on an ad hoc basis. The following recent deployments confirm this point:

□ Desert Shield/Desert Storm (Saudi Arabia). MTMC was not responsible for managing SPODs during deployment. Gradually, MTMC was assigned theater responsibility and eventually took over port management during the redeployment and retrograde phases.

□ Restore Hope (Somalia). MTMC deployed three personnel temporarily to conduct port assessments. They were not assigned a port management role.

□ Rwanda Hope (Somalia.) MTMC deployed to Mombasa, Kenya, and performed the full range of port management functions.

□ Uphold Democracy (Haiti). MTMC was among early deployers but did not have full responsibility for port management.

□ Vigilant Warrior (AWR3 discharge). MTMC was among the first on the ground; providing the CINCCENT with predeployment planning for port

operations, contracting for facilities and commercial stevedore support, and performing the full range of port management activities.

Experience gained in these operations demonstrates the need for and value of more consistent port management doctrine and seaport organization similar to that employed at aerial ports by AMC. DOD has a substantial investment in the CONUS port infrastructure. However, there is no similar deployable management force structure and doctrine for operating overseas port facilities.

A port management organization with a family of port and cargo management systems is needed to incorporate advances in information processing and communication technologies. Reduced inventory levels and increased dependence on direct vendor support, as envisioned by the BD concept, also require such an organization. To support the ITV/TAV elements of BD, a strategic distribution system must be effectively managed. Movements must be documented at every echelon in an accurate and timely manner.

A set of responsibilities has been defined that will capitalize on MTMC's expertise and core competencies at contingency SPOEs/SPODs. It solidifies MTMC's role in all scenarios as an early deployer to any theater to provide the CINC with expert port management, transportation engineering, and transportation systems support. The result will be synchronization of intertheater movement between strategic and common-user SPOEs and SPODs. In laying the groundwork for the port management concept, the following must be considered:

- Military capability is required to manage, and may be required to operate, the port(s) in the theater of operations.

- The supported CINC determines command and control relationships between units with responsibilities at theater ports.

- The specific responsibilities and command relationships normally detailed in the CAA will be followed.

- Force structure, command relationships in the operational theater, and some aspects of port

management and operation functions vary from one operation to the next and will be METT-T driven based on each scenario.

- Army doctrine will designate MTMC as the port manager and the transportation group (composite) the port operator.

- Where discrepancies exist between Army doctrine and an individual CAA, METT-T and the CAA will govern.

Responsibilities

Under the port management concept, the port manager and the port operator each have specific, clearly-defined roles and functions.

Port manager. As port manager, MTMC supports the JTF/CTF/CINC staff. The MTMC performs the following functions:

- Participate in the CINC OPLAN development and analysis.

- Conduct assessments of contingency ports to include a transportation engineering assessment.

- Advise the CINC as to the appropriate mix of military and civilian port operating capability required for a given contingency based on METT-T.

- Establish liaison with designated HN port authorities for acquiring water terminal facilities and related services.

- Develop statements of work and contract for stevedoring and related terminal services where such services are commercially available.

- Operate WPS, ICODES, IBS, and other theater water terminal transportation/logistics ADP systems.

- Book inter- and intra-theater surface cargo on MSC controlled common-user ships and liner service.

- Provide common-user container management services.

- Administer MSC ocean carrier contracts and vessel charters.

- Arrange for transition of military operating capability to a commercial contract or HNS.

- Participate in planning and execution of redeployment.

- Work load the port (such as provide vessel discharge priorities, ship schedules, and manifest data to the port operator based on the theater commander's intent).

- Provide inter-theater documentation oversight, documentation services for MSC negotiated commercial liner contracts, and other documentation services as determined by METT-T.

- Provide communication/ADP technical support for transportation/logistics ADP systems related to theater water terminals.

Port operator. As port operator of a contingency SPOD, the transportation group (composite) or transportation battalion (terminal) will perform various functions. These functions include the following:

- Beach and port preparation and improvement.
- Cargo discharge and upload operations.
- Harbor craft services.
- Ship-to-shore movement of cargo and lighterage control.
- Heavy lift services.
- Beach and port clearance command and control.
- Cargo documentation for reception, staging, and onward movement of personnel, equipment, and supplies to provide ITV to the supported CINC.

Concept of Operations. The following actions/steps are key to properly executing the port management concept:

- During the TPFDD development/refinement phase of the planning process, MTMC will provide planners to the supported CINC to develop port management and port operations requirements.

- In crisis action scenarios, MTMC will provide planners to the supported CINC for SPOD assessment and TPFDD development.

- At the request of the supported CINC and at USTRANSCOM direction, MTMC will deploy an advance party to conduct port assessments, establish contact with local port authorities, and determine availability of HNS in terms of both labor and equipment. Based on the advance party assessment and other METT-T factors, MTMC will recommend the appropriate mix of military, HNS, and civilian port operating capability required to support the contingency.

- Prior to the arrival of the first vessel, the tailored port opening package—to include the balance of the MTMC Management Cell—will deploy to the theater to support SPOD management and operations.

- MTMC will perform the theater port manager function using management cells with elements located with the CINC/JTF/CTF staff and at each designated common-user SPOE/SPOD. These organizations will perform the functions necessary to control the strategic flow of cargo and information between SPOE and hand-off to the theater (see Table 3-1).

- MTMC's port management organizations will be provisionally staffed by preselected military and civilian personnel with the basic skills needed to perform contingency port management functions. These organizations will have a rapid transition-to-war capability since most of the assigned personnel will be performing functions similar in nature to their daily peacetime activities.

- Besides the personnel and skills needed to ensure port management success, port management organizations will have and be able to use high quality information management tools including WPS, ICODES, and IBS. The MTMC management cell will deploy with and operate the C31 port management center.

- A tailored Transportation Group or Transportation Battalion (Terminal) will normally perform port operations functions requiring US military capability. In all cases, this organization should be operational in theater before the first vessel arrives. The port operator will perform the following:

- Execute the reception, staging, and onward movement of equipment and supplies.

- Ensure the expeditious, well-documented transfer of deploying unit equipment into the theater of operations as directed by the theater MCA.

- In keeping with the goal of freeing military units for other possible contingencies, the supported CINC should seek to transition from a military port operation to a commercial port operation as soon as tactical conditions permit. Possible alternate port operators include HNS, third country commercial contractors, or LOGCAP. While port operators may transition between different organizations during the contingency, MTMC will perform the port manager function throughout the predeployment/deployment/redeployment process.

- Where HNS and/or commercial contractors can support all port operations requirements, there will be no requirement to deploy military units to perform these functions. In this scenario, only the MTMC management cell will deploy to establish and administer actual operations through commercial contracts.

Table 3-1. MTMC port management cells

	STATUS	GRADE/ OCCUPATION	A	B	C	D
Command and Control						
Commander	MIL	COL/88A	1	1	1	1
Deputy	MIL	LTC/88A	1	1	1	1
NCOIC	MIL	MSG/64Z	1	1	1	1
Clerk/Driver	MIL/CIV		1	1		
Technical Support						
Contracting officer	MIL/CIV		1	1	1	1
Communication support	CIV		1	1		
ADP systems support	CIV		2	2	1	1
Transportation engineer	CIV	2101	1	1	1	1
Operations Section						
Operations team chief	MIL	MAJ/88A	1	1		
Assistant team chief	MIL/CIV		1	1		
Operations NCOIC	MIL	SFC	1	1		
Operations administrative assistant	MIL/CIV		1	1		
Container manager	MIL/CIV		1	1		
HAZMAT/Ammunition	MIL/CIV		1	1		
Transition planner	MIL/CIV		1	1		
Chief documents supervisor	MIL/CIV		1	1		
Deputy documents supervisor	MIL/CIV		1	1		
Freight movement supervisor	MIL/CIV		6	6		
Port Management						
Commander	MIL	LTC/88A	2	1	1	1
Transportation plans officer	MIL	MAJ/88A	2	1	1	
Contract officer	MIL/CIV		2	1	1	1
Cargo officer	MIL/CIV		2	1	1	1
Movements supervisor	MIL	SFC/88N	2	1	1	
Movements supervisor	MIL/CIV		4	2	2	1
Documentation clerk	MIL/CIV		10	5	4	2
TOTAL			48	36	17	12
Cell A - ASMP deployment—operate two ports. Discharge all PREPO and strategic sealift ships for two heavy divisions by C + 30. Forty-two ships total; seven-berth surge requirement.						
Cell B - LRC deployment—operate a single port. Discharge selected PREPO and eight strategic sealift ships by C + 15. Twelve ships total; three-berth surge requirement.						
Cell C - Peace-enforcing and humanitarian mission. Select PREPO and four strategic sealift ships by C + 15. Six ships total; two-berth surge requirement.						
Cell D - Small humanitarian mission. Three ships total by C + 15; single-berth operation.						
NOTE: CIV COULD BE CONTRACTOR OR LN PERSONNEL. ACTUAL NUMBER OF PERSONNEL IS METT-T DRIVEN.						

MARINE TERMINAL PLANNING STEPS

Marine terminal planning involves six basic steps developing logically from the preceding one. These steps are as follows:

- Determine the type or category of existing terminals. For example, container, RO/RO, break-bulk, special commodity (ammunition), bulk fuel, or a composite capability for multipurpose or combi-terminals.

- Estimate the existing terminal throughput capacity. This is the estimated total tonnage and numbers of personnel and containers that can be received, processed, and cleared through the terminal in a day. (A day is two 10-hour shifts plus two 2-hour maintenance periods.)

- Compute the terminal workload needed to support the operation. The workload is expressed as numbers of personnel, vehicles, containers, and STONs for noncontainerized cargo. This computation includes the total tonnage and numbers of personnel and containers that must be received, processed, and cleared through the terminal.

- Determine the repair and rehabilitation of existing facilities and/or new construction needed to increase existing terminal throughput capacity to equal the computed terminal workload. Normally, existing terminal capacity is insufficient to support the operational workload.

- Estimate the MHE needed to process the required workload. Equipment such as tugs, barges, and floating cranes; and the personnel to man them, are identified in TOE 55-530.

- Estimate the units, individuals, and supervisory and command elements needed to operate the terminal. TOE 55-560 lists team personnel and equipment available to augment terminal operations. Security personnel requirements should also be included in case MP or HNS is not available.

PLANNING CONSIDERATIONS

Countering the Threat

The presence of the US in nations around the world may provoke a wide range of responses by factions, groups, or forces of an unfriendly nation. Regardless of the mission, commanders must protect their forces at all times. Rear operations can be the target of the enemy's deep attack. To preclude diverting assets

needed for close operations, commanders train and equip units involved in rear operations to protect themselves against all but the most serious threats. The terminal command must ensure that the soldiers involved in a marine terminal operation are prepared to meet this challenge.

Water terminals are critical logistic installations that are high-value targeted and must be safeguarded by both active and passive means. These terminals will be susceptible to air and missile attack, hostile unconventional forces, sabotage, terrorism, mining, and espionage.

The S3 is responsible to the terminal commander for planning the defense of the terminal. This plan will be in coordination with any of the following:

- US Navy.
- US Coast Guard.
- HN civil defense forces.

Most harbors and ports are physically laid out so that limited dispersion can be achieved within the boundaries of the port itself. Dispersion within an established terminal does not permit maximum port use. However, it does allow the commander to take partial advantage of the many port facilities without unduly endangering the mission. The extent to which the commander uses the established terminal represents a calculated risk. He must carefully evaluate the probability of an attack that could destroy the port and consider its subsequent effect on the theater logistical plan. Further information can be found in FM 55-50, Chapter 1.

Port Security

Port security refers to the safeguarding of the cargo and equipment that is discharged from the ships. The responsibility of port security belongs to the port commander. Availability of existing port security elements determines whether the port commander deems augmentation to be necessary. Those security elements already present might consist of security fences, controlled storage areas, warehouses, electronic surveillance, and alarms.

A Reserve Component Port Security Company may be required to augment existing port security elements. The PSC works for the physical security officer within the S3 section of a terminal battalion or group.

The PSC administers the port commander's physical security plan. The goal of the plan will be to keep unauthorized personnel out of the area. Such persons may engage in sabotage, petty and large-scale theft operations, and establishment of inside contacts with foreign nationals or others working in the terminal or marshaling yards.

Cargo

The amount of containerized cargo, break-bulk cargo, and rolling stock greatly influences the transportation plan. In peacetime, the estimated ratio of containerized to noncontainerized traffic is 80:20. In wartime, the large volume of unit equipment to be deployed initially reverses this ratio, but as the theater matures, the original ratio resumes. Packaging dictates a need for specialized equipment and trained personnel. Cargo handlers may need to construct special slings and bridles to move heavy, outsize, or special cargo. Some cargo requires covered storage sites. Dangerous or hazardous cargo requires careful handling, segregation, or possibly a separate and isolated terminal. A great amount of ammunition is transported through marine terminals. The transportation planner must evaluate the terminal operation plan to project which areas will handle shipments of ammunition and other hazardous cargo. Ammunition requires special equipment such as electric forklifts. Ammunition should be stored in a segregated area. QSTAG 590 standardizes markings and handling and storage instructions for cargo consignments and international transport of military cargo.

Theater Geophysical Characteristics

Terminal planning to support a TO requires a study of the geophysical characteristics of the total theater. Physical characteristics and layout of the port and/or beach must be considered, as well as the logistics support requirements determined by the overall scheme of operations. Highway and inland waterway networks must be studied relative to their locations as well as those of supported and supporting units. Terminal units must be selected to operate terminals and terminal transfer points. In both planning and operation phases, the mission, personnel, and physical facilities must be balanced. This may involve using beaches,

rehabilitating destroyed or damaged piers, constructing new piers, upgrading unimproved port facilities, and/or using indigenous or contract labor and equipment.

Personnel and Equipment Requirements

Using the ship and the terminal service company as basic factors, the personnel and equipment requirements may be determined. Upon defining these needs, planners can estimate requirements quickly and accurately for pier and/or beach operations.

OPERATIONAL PLANNING

The plans, operations, and security section of the terminal battalion begins planning immediately on mission assignment. The mission to discharge a specific ship is accompanied by the ship's papers (cargo stowage plan, hatch lists, and ocean manifest) and the cargo disposition instructions. Initial planning is based on these papers and available personnel and equipment. It includes determining the following:

- Point of discharge (wharf or anchorage).
 - Piloting services.
 - Types of terminal units required.
 - Tugboat requirements.
 - Equipment required for special or heavy lifts.
 - Priorities of discharge, if any.
 - Arrangements for terminal clearance, including transportation required and the need for temporary holding or further segregation.
 - Security and safety requirements.
 - Spill contingency plans including emergency supplies and equipment for containing and disposing of hazardous material spills.
 - Estimates of hatch and/or vessel completion times.
 - Considerations of specific ship characteristics.
- For example, shore cranes may be used to stage flat racks and/or sea sheds for fast sealift ships.

AMMUNITION AND HAZARDOUS AND/OR CLASSIFIED CARGO

Army terminal operations will involve movement, handling, and storage of hazardous materials through

areas which are particularly sensitive to environmental damage. Preventing damage to the environment must include attention to accidental and routine operational causes as well as enemy action and sabotage.

The special requirements for handling ammunition, explosives, bulk fuel, and other hazardous cargo must be planned for along with port restrictions such as the vessel's NEW. Provisions must be made for classified storage facilities. Personnel must be properly cleared to handle classified cargo. Constant coordination is needed between terminal operators and ammunition units for inspections, unloading, clearance, courier service, safety, and special security requirements for conventional and special ammunition entering terminals. Special requirements governing the transport and handling of military explosives and other hazardous cargo aboard vessels and in ports are in CFR 49. Special shipping instructions for military biological research material and hazardous cargo are in AR 55-228. (See AR 700-65 for nuclear weapons and nuclear weapons materiel.) For hazardous chemical shipments, FM 101-40 requires a munition safety control (technical escort) unit to guard shipments, protect personnel handling the shipments, and dispose of damaged munitions and decontaminated objects and areas accidentally contaminated during shipment. TM 3-250 and TM 9-1300-206 give details on handling chemicals and ammunition. FM 3-5 gives information on decontamination. FM 8-285 gives first aid instructions for individuals exposed to chemical agents. NAVORD-OP 5 gives details on loading and stowing ammunition and explosives aboard ship.

TERMINAL CAPACITY

There are seven basic types of dry cargo, nonbulk terminals. They differ drastically in their intended purposes and layout. Matching them with the right type of ship and cargo packaging, results in their intended efficiency. The seven types include the following:

- Break-bulk.
- RO/RO.
- Container.
- Container and/or RO/RO.
- Combination.
- Lighter.
- Passenger.

Terminal throughput capacity estimation is a very careful evaluation of five functional areas (see Table 3-2). These areas include reception, discharge, transfer, storage, and clearance. Threat, weather, labor, and other factors that are not functions of the estimating process must also be considered. The five functional areas are described below.

Reception

This capacity is based on the number of ships (by type, length, and draft) that can be berthed in a harbor or at a terminal.

Fixed berths. The best type of ship and an alternate for this berth depend on the type of terminal at the berth; for example, container, break-bulk, and RO/RO.

Vessels require 75 to 100 linear feet of berth length in addition to their measured LOA. Therefore, the longest vessel or combination of vessels must be 75 to 100 feet less than the length of the berth. The minimum water depth alongside the berth at mean low tide determines the maximum allowable draft for vessels at that berth. A ship should always have at least 2 feet under its keel for safety of the vessel.

Anchorage berths. For military planning, ships anchor either offshore or in-the-stream (harbor). Other methods exist, but these two are used for military purposes so the ship can get underway quickly. Use the following formulas to determine the required size (diameter) of an anchorage site for a ship:

$$\text{Offshore: } D = 2(7d + L)$$

$$\text{In-the-stream: } D = R(4d + 2L)$$

Where:

D = diameter

d = depth of water

L = length of ship

R = reserve factor (1.1)

Use the following formulas to determine the largest ship that will fit properly in a given area:

$$\text{Offshore: } L = \frac{D - 7d}{2}$$

$$\text{In-the-stream: } L = \frac{D - 4d}{R}$$

Table 3-2. Terminal throughput capacity estimation checklist

COLLECT THESE DATA:	COMPUTE THESE FACTORS:	TO DETERMINE:
<ul style="list-style-type: none"> • Channel depth • Channel width • Length of berths • Type of berths (such as quay, pier, and mole) • Diameter of anchorages • Depth of water at berth • Type of terminal at berth • Discharge equipment on board • Discharge equipment ashore • Width of apron • Special lift equipment • Number of discharge equipment • Type of cargo • Type of cargo-handling equipment • Round-trip distance • Number of cargo-handling equipment • Intrinsic capacity • Average dwell time • Operating capacity • Terminal facilities • Stacking methods • Equipment used • Clearance conveyance by mode • Terminal equipment and personnel • Gate capacity 	<p>(1) Marine terminal reception capacity</p> <p>(2) Marine terminal discharge capacity</p> <p>(3) Marine terminal transfer capacity</p> <p>(4) Marine terminal storage capacity</p> <p>(5) Marine terminal clearance capacity</p>	<p>Marine terminal throughput capacity for importing cargo only.</p> <p>(Retrograde operations will reduce the import capacity.)</p>
<p>NOTE: Once all of the above evaluations are completed, then evaluate the following: threat assessment, affect of the elements, and training level of labor.</p>		

Discharge

The cumulative amount of cargo that can be discharged from each of the berths is-terminal discharge capacity. This is an evaluation of discharge facilities and equipment found on the berths as well as on the

type of ship to be docked on the berths. It is expressed in STONs, containers, MTONs, square feet, or numbers of personnel.

Break-bulk berth. With the berth operating on a 24-hour basis at 75 percent availability of CHE, 2,500 STONs of break-bulk cargo can be discharged each day per berth.

Lighters berth. Using one crane per lighter during discharge operations, the berth can discharge 300 STONs of break-bulk, 450 STONs of ammunition, or 200 containers per day.

RO/RO berth. Loading and discharging areas for various classes of RO/RO vessels vary greatly. Since MSC vessels are loaded under conditions more likely to be encountered during a military contingency, their short-term rate of 600 MTONs or 3,898 square feet of cargo per hour is recommended for planning purposes. A RO/RO terminal should have 10 acres of open hard surface space with at least a 100-foot apron.

Underdeveloped container berth. The discharge rate of 300 containers per day applies when off-loading or loading containers using US Army heavy lift cranes working at anchor alongside a ship in an underdeveloped fixed port. If back-loading is conducted at the same time as off-loading, the back-loading rate equals about one-half of the discharge rate for off-loading only. This berth should have at least a 100-foot apron.

Developed fixed container terminal. When using container-handling cranes at a fully developed container facility, the simultaneous discharge and loading rate is between 700 and 800 containers per 24-hour period. The rate of discharge at any container terminal depends on the type of CHE, type of ship being worked, and the number of container cranes used. The number of cranes per terminal and berth often varies between terminals. The size of the container does not affect the rate of discharge. If container-handling and transport equipment is available, all containers can be handled at the same rate.

□ LASH. The average ship discharge rate is one lighter every 15 minutes and one container every 3 minutes.

□ SEABEE. The average ship discharge rate is two barges every 25 minutes and one container every 3 minutes (if containers are carried in lieu of barges on the main deck).

Computations. Capacity is based on the capability of discharge methods and equipment used. Historical reports, shipper's reports, and realistic evaluations

help in the estimation. The shortage of personnel must also be considered. Figure 3-1 is a sample worksheet for discharge capacity.

Transfer

This is an evaluation of the capacity to move cargo from the discharge point to the storage point. It can be a time, equipment, and motion study that considers the number of moves available. For example, transfer capacity is the time it takes to move a pallet of cargo from the ship's side to the storage area, deposit it, and return to the ship's side. It is measured the same as the discharge capacity. Transfer capacity is used twice (once for the lighterage and once with the MHE on the beach) when discharging ships at LOTS sites or anchored in the stream.

Storage

This is the amount that can be stored at any one time. Storage capacity is given as an intrinsic capacity to obtain the operating capacity. The operating capacity depends greatly on the average dwell time of the cargo. Some cargo space must be left empty so that space is available to move cargo. Experience shows that congestion in the storage area begins at about 60 percent and is complete at 80 percent of the intrinsic cargo capacity of the terminal.

Clearance

This is the ability, measured like discharge capacity except by mode, to clear cargo from the terminal. The terminal clearance capacity may be limited by either of the following:

- Number of clearance conveyances.
- Ability of terminal equipment and personnel to load clearance conveyances. Clearance conveyances for military purposes includes, but is not limited to, trucks, railcars, lighters, and helicopters.

Throughput

In every instance, the least of the discharge, transfer, or clearance capacity is the terminal's throughput capacity. All capacities must be estimated carefully considering all aspects of the situation even if the limiting capacity is obvious. This makes it possible to determine where improvements can generate the greatest increase in throughput capacity.

plan to receive the cargo. Based on cargo disposition instructions, the terminal battalions plan and give specific assignments to terminal units for discharge of vessels and terminal clearance.

After the disposition of the incoming ship is decided, the terminal brigade or group must coordinate a number of actions before ship discharge and port clearance operations can commence. These actions mainly consist of the following:

- ❑ To receive detailed cargo disposition instructions for military and civilian aid cargo, including diversions and detailed routing instructions from the TAMCA.

- ❑ To arrange clearance of personnel and cargoes directly forward, bypassing rear area facilities.

- ❑ To assign individual ship berths.

Ship berth assignments require coordination with local MSC representatives and may also involve local HN authorities. The assignments are usually made at the terminal battalion level. Detailed disposition and routing instructions for personnel, US allied military cargo, and military aid cargo, require coordination with the MMC, the MCA, the PERSCOM, and the recipient nation or allied command. Liaison officers attached to the terminal group coordinate the latter. Disposition of civilian aid cargoes requires liaison with government representatives of the recipient nation. Foreign liaison officers and US civil affairs personnel may assist in this matter. The TAMCA provides detailed routing instructions for US military cargo and has MCTs at each discharge site to assist terminal personnel.

VESSEL UNLOADING

Based on the vessel manifest and cargo disposition instructions received, the terminal battalion plans the discharge of individual ships before their arrival. This planning includes the following:

- ❑ The specific location to be used within the terminal.

- ❑ The method of discharge (floating or shoreside cranes, pier or offshore discharge, and the order of hatches and cargo within the hatches to be worked).

- ❑ The designation of specific units to work each vessel.

The operating terminal battalions work closely with the local transportation movement teams. The terminal battalions ensure that variations from the vessel

discharge plan are coordinated with clearance mode operators. Proper coordination prevents unnecessary delays in port clearance.

Detailed procedures and techniques for unloading cargo vessels are in FM 55-17. A terminal service company is assigned the mission of unloading cargo from a vessel. Before moving or unloading cargo, a boarding party boards the ship to coordinate with the vessel master. In small operations or when the vessel calls on the port frequently, the boarding party may consist of only the boarding officer (normally the battalion operations officer or terminal service company commander). During this visit and inspection of the ship and cargo, the boarding party may decide to alter the discharge plan made before the ship arrives. Unforeseen conditions such as damage to the ship's gear, unexpected priority cargo, or oversize or heavy lifts not noted on advanced stow plans, may change the initial discharge plan. In more complex operations or when the ship calls on the port infrequently, the boarding party may be composed of any or all of the following personnel:

- ❑ Terminal operations officer. He determines and reports the general condition of the ship's equipment and facilities. He also delivers pertinent terminal regulations and the terminal commander's orders to the vessel master and to the military troop commander. He obtains copies of the ship's papers when advance copies have not been received and determines major damage to or pilferage of cargo. He also obtains other information pertinent to unloading the vessel's cargo.

- ❑ Customs representative. He checks for clearances, narcotics, weapons, and contraband and performs other necessary customs activities according to theater directives and HN laws.

- ❑ MSC representative. He determines from the ship's officers the requirements for repairs, fuel, and storage. He also delivers MSC instructions to the vessel master.

- ❑ Surgeon and/or veterinarian. He checks for communicable diseases, sanitary conditions of personnel spaces and facilities, and condition of perishable cargo.

- ❑ Harbormaster. He coordinates matters on berthing, tug assistance, and employment of floating cranes and other harborcraft under his control.

- ❑ Ship platoon leader. He coordinates the detailed plans for cargo loading and unloading.

□ Lighterage unit representatives. He coordinates plans using lighters to unload vessels at anchorage berths.

□ Troop movement officer. He coordinates plans to move troop units or casualties through the terminal.

□ MP representative. He determines the needs and plans for providing MP support required during unloading and debarkation operations.

Although the boarding party coordinates with the vessel master when the ship first arrives, the vessel master normally designates one or two of his officers for coordinating operational matters. Frequently, the vessel master may direct that he or his representative be notified of changes in stow plans, when ship's gears are rigged or spotted, when hatches are opened or closed, when heavy lifts are rigged, or when the vessel sustains any damage. It is not unusual for vessel masters to insist that the ship's personnel rig the ship's gear, open and close hatches, or even operate winches. These requirements should be coordinated early in operational planning and the special requirements noted in the ship's files so planning for subsequent discharge operations is easier.

PRODUCTIVITY

Chapter 2 specifies the capabilities of the terminal service companies (container/break-bulk). Procedures for computing terminal throughput are in the terminal capacity paragraph. These production figures are adequate for long-range or general planning. However, they are inadequate for the short-range planning needed to determine such things as shift production or estimated time of completion for individual hatches.

The production capabilities for the break-bulk and container terminal service unit are based on the production from working five-hatch, break-bulk cargo ships and commercial container vessels. In a developed marine terminal, operations might entail discharging watercraft and barges in addition to general cargo, RO/RO, and containerships. Production figures for these smaller carriers vary significantly from those of the larger vessels and are therefore developed locally.

Many factors affect production during discharge operations. Weather, sea state, visibility (fog and darkness), crew experience, the type of lifting gear (shore crane or ship's gear), cargo stow tactical situation,

and terminal congestion and packaging all affect discharge productions. The sum of these positive and negative influences results in the number of lifts that can be obtained per hour. Lift capacity can be computed by hatch or for the entire vessel. It can be obtained by timing the lifts for a specified period or by computing information from tally sheets at the end of a shift.

Many factors may influence actual cargo discharge production. Unit productivity specified in applicable TOE is adequate for general planning purposes. However, it should not be used to measure unit efficiency. The fact that a unit does or does not discharge 2,500 STONs per day may have little relationship to real efficiency without adequately considering the factors mentioned in the previous paragraph. These factors and others promote or detract from actual productivity. Unit efficiency must be judged on the basis of factors and conditions as they affect a specific discharge operation. Attaining 2,500 STONs of production is insufficient if a majority of the unit was idle or less than gainfully employed, or if the operation was inefficient as reflected by unnecessary or excessive nonproductive time. On the other hand, attaining a lesser tonnage production might be considered exceptional if accomplished under less than ideal circumstances (such as operational variables and difficulties and insufficient TOE). Personnel responsible for managing cargo discharge and port clearance operations must constantly evaluate those operations to improve efficiency and productivity. Assigning a terminal service company to work a general cargo vessel would waste manpower if all hatches were not scheduled to be worked. On the other hand, an extra gang or shift on a long hatch might result in the ship sailing a day earlier than normal operations might allow. In the case of unit moves on RO/RO vessels, productivity may increase if personnel from the moving unit unlash rolling stock (wheeled vehicles) and drive vehicles off the ship under the supervision and direction of terminal service personnel. This procedure allows the bulk of the terminal service personnel to work, in total or in part, another vessel. Unit productivity and efficiency is vastly improved.

CARGO CLEARANCE

The MCT representative coordinates with the terminal and mode operators for placement of appropriate

transport at locations and times necessary to clear cargo from the terminal. This is based on the location of and the requirements for transport. Cargo clearance is the act of moving cargo from shipside or temporary storage to its first destination outside the terminal operating area. This first destination may be the final destination or it may be a rear area depot. Destinations will be identified in the cargo disposition instructions.

Ideally, heavy maneuver units will move their tracked vehicles from the port to follow-on staging areas by means of nondivisional HETs. The division MCO will coordinate for these assets through the Corps MCC.

Nondivisional HETs will be allocated in accordance with mission priorities. The use of nondivisional HETs will be augmented by divisional HETs when necessary. Throughout movement operations, special emphasis will be placed on preserving unit integrity. If sufficient HET assets are unavailable to complete the mission, heavy maneuver units will use division or corps medium trucks to move lighter tracked vehicles. Coordination for these assets will be made through the division MCO. Use of division or higher HET assets may be augmented by other modes of transportation, such as rail. In a situation where tactical considerations are not paramount, it may be ideal to move heavy units by rail. However, in a tactical environment in which flexibility and responsiveness are essential, the use of HETs will be maximized.

Prompt clearance of cargo is important. It is essential to the efficiency and success of the total theater logistics systems. It is also necessary to avoid congestion in the terminal area. A continuing cargo backlog feeds on itself and slows operations to a point that the entire terminal effort collapses. Also as cargo builds in the terminal, it reduces the amount of dispersion that can be achieved. This increases the security risk. It also increases the requirements for camouflage and deception schemes to provide operational security.

The most efficient method of clearance is to discharge cargo directly from the ship to clearance transport. However, operating conditions often do not permit this. The following conditions may prevent direct clearance from shipside:

- Cargo that cannot be segregated without delaying operations.
- Special situations that require segregation by time, lot, or weight.

- Lack of proper transport.
- Inability of receiving installations to accept cargo.
- Delays in receiving cargo disposition instructions.

When such conditions exist, cargo should be moved to temporary in-transit storage areas. Temporary in-transit storage areas are usually next to or very near the pier discharge area. Cargo should never be placed in temporary in-transit storage areas until every effort has been made to clear it from the terminal. If temporary holding is necessary, the cargo held should not exceed one day's discharge. It should be cleared from the terminal at the earliest possible time. If the amount of cargo in the temporary in-transit storage areas becomes excessive, a terminal transfer element (platoon or company) should be attached to the terminal service company to load clearance transport equipment as it becomes available. The number and location of temporary in-transit storage areas within the terminal depend on many factors. Some of these factors consist of the following:

- Availability of suitable sites.
- Type and quantity of cargo to be discharged.
- Equipment and personnel available.
- Location and modes of transportation used in the terminal clearance operation.

The areas should have a hard, all-weather surface and should be located between the discharge points and the inland transportation net. This would permit efficient use of MHE to move cargo from shipside to the area, within the area, and from the area to the transportation net. Emergency supplies and equipment for containing hazardous material spills should be readily available at or near temporary storage areas.

VESSEL LOADING

The main function of a terminal operation organization in a theater is the reception, offload, and transshipment of personnel and material. However, sometimes personnel and supplies must be loaded aboard vessels. These outbound movements may vary from small- to large-scale shipments of cargo and/or personnel. The terminal commander's responsibility for outbound cargo is essentially the same as for inbound cargo. The main difference is that the operation is performed in reverse order. It includes initiating port release; booking, receiving, and stowing cargo; and preparing necessary documentation. The terminal

group commander assigns the loading mission to a terminal battalion and coordinates as necessary with the MSC.

The transportation element of the TA DCSLOG, sets up procedures to move freight from points within the theater to the terminal for further movement to CONUS or other destinations outside the theater. These procedures generally provide for the shipping agency to submit a request through its supporting MCT. Once the TAMCA receives the request, it then coordinates the necessary shipping actions at the periodic ship destination meeting.

The terminal group issues cargo booking information to the terminal battalion operating the selected terminal. This information is used to preplan vessel stowage, storage requirements, and operational workload. When the berthing time of the vessel is definitely established, the battalion assigns the loading mission and sends the subordinate units information on the following:

- Location of the loading berth.
- Time that loading is scheduled to begin.
- Time that cargo is to be received.
- Estimated departure date of the vessel.
- Special cargo to be loaded and MHE required.

Plans are made for the receipt, temporary holding, and movement of cargo to the loading area. The terminal battalion forwards port releases to the shipping agency. Port releases are carefully scheduled to prevent interference with the terminal clearance program and to avoid delays in loading.

When the nature of the cargo has been determined, the battalion prepares a prestowage plan for loading the particular vessel with the cargo. The appropriate vessel authority receives the prestowage plan for approval. Upon the vessel's arrival, the ship's master or his representative receives the plan for final approval. When the vessel is berthed, the holds, hatches, and the ship's gear are thoroughly inspected for any difficulty that might arise during loading operations.

The prestowage plan becomes the basis on which to call cargo forward to the terminal area. In calling the cargo forward, the battalion commander must consider planned loading time aboard ship and the area available for temporary holding if the cargo arrival time and loading time do not coincide. It is desirable to have enough cargo on hand to sustain one day's

loading before starting loading operations. This ensures continuous loading in case some shippers cannot meet the planned port call date. Cargo received before the loading time must be moved into temporary in-transit storage areas so as not to interfere with any clearance operations.

Retrograde cargo, such as containers, trucks, tanks, aircraft, SEAVANs, and MILVANs, being returned to CONUS are prepared and processed for CONUS Department of Agriculture quarantine inspection. This is done before cargo is loaded aboard aircraft or vessels. Plans should be made in advance to have adequate cleaning equipment and appropriate insecticide chemicals and rodent poison on hand. This ensures that retrograde cargo can be promptly and properly processed.

DOCUMENTATION

Cargo moving through Army terminals is documented according to DOD Regulation 4500.32-R, Volumes I and II. The basic document for all cargo movements under these procedures is DD Form 1384 (TCMD). This form and its use is described below.

DD Form 1384

This multipurpose form can be prepared manually or electronically. The manual version of the form is a seven-part document. Originated by the shipper for each transportation unit, the TCMD data (not necessarily the document) accompanies the shipment from the origin to the consignee. Detailed procedures for preparing and processing the TCMD and allied documents are in DOD Regulation 4500.32-R, Volumes I and II. STANAG 2166 (see Appendix A) contains standardized movement and transport documents for ship transport. The TCMD is used for the following:

- To provide advance notice of shipment to consignees.
- As an airbill, a highway waybill, a dock receipt, and a cargo delivery report.
- For movement control of shipments worldwide within the DOD transportation system, including in-transit reporting and tracing actions.
- As a source document for mechanically prepared air and ocean manifests.
- As a source of logistic management data.

Inbound movements. For ships loaded in CONUS, MTMC transmits information to the discharge terminal and the TAMCA. The TAMCA provides a copy of the manifest to the inventory control center so it may make any necessary changes in consignee or destination of the cargo. The TAMCA incorporates any necessary changes and transmits manifest information to the terminal command element responsible for discharging the ship. Depending on the degree of sophistication of the computer and program the TAMCA uses, hatch tallies and partial TCMDs may also be provided to the terminal element. The terminal battalion reproduces the incoming data in a format and in the number of copies needed to actually discharge the ship. The TAMCA provides detailed cargo disposition instructions.

Upon the ship's arrival, the reproduced manifest is the basis for checking the cargo off the ship. The data on the quantity, identity, and condition of incoming cargo developed by the unloading terminal service unit are used to prepare the cargo outturn message and to reconcile the manifest. Upon reconciliation of the ship discharge data with the manifest, the terminal battalion prepares a cargo outturn report. The terminal battalion forwards the report to group HQ for transmission to MTMC and other interested agencies listed in DOD Regulation 4500.32-R, Volumes I and H. (See AR 55-38 for reporting transportation discrepancies in shipments.)

The above general procedures may have to be modified when ships arrive from theaters other than CONUS. This is especially true if no data processing equipment is available at the loading port. In this case, the manifest is forwarded by airmail or courier to the terminal group, which retransmits it to the designated discharge port. If the sea distance is short, the manifest may not arrive before the ship. Therefore, the terminal battalion responsible for discharging the ship may have to obtain a copy of the manifest from the ship's master.

The TCMD is normally the basic document for checking and documenting incoming cargo. However, other forms, such as tally sheets, may be used for internal accountability. When drafts of cargo are moved away from the ship, the cargo checkers begin internal accountability. Throughout the terminal, cargo checkers check the cargo in and out and direct cargo to

its next destination. When cargo is put into the in-transit storage area and/or loaded aboard the clearance conveyance, the TCMD is properly annotated.

The unit commander is responsible for the checkers. He determines how often the cargo must be checked and is accountable for all cargo. The system must be sound and must allow a smooth and constant flow of the cargo with an accurate accountability.

Except when cargo is moved directly from shipside to a local consignee, cargo must be reconstituted into transportation units, such as railcar loads or line-haul truckloads, before clearing the terminal area. These units may differ from those in which the cargo left shipside and may require new TCMDs. A copy of these new and more complete TCMDs accompanies the cargo to destination. The TCMD forms the basis for preparing bills of lading, freight warrants, and train manifest as required. The documentation section of the terminal battalion uses the hatch checker's partial TCMDs or tally sheets and the TCMDs prepared to cover onward movement to reconcile the ship's manifest. They are also used to prepare cargo outturn messages and outturn reports. Movement control personnel use them to notify consignees (report of shipment) in advance that shipments are en route and to follow the shipment's progress to destination.

Outbound movements. Procedures for offering cargo for shipment, handling movement releases, and documenting outbound cargo are coordinated between the theater movement control activity and the OCCA. Procedures are subject to theater regulations, as well as AR 725-50 and DOD Regulation 4500.32-R, Volumes I and II. Determination of what moves and its priority is coordinated at the theater movement control activity.

The TCMD covers outbound movements in either manual or automated form. Freight warrants and/or bills of lading cover the cargo if it is shipped to the loading port by commercial means. The TCMD serves as backup for these documents.

When planning for outbound cargo handling, the terminal commander must consider the size of the shipment and the type of cargo. These effect the choice of loading berth, equipment, and personnel. He must also consider the volume and schedule of inbound traffic and clearance requirements.

The terminal service unit actually charged with loading the cargo prepares prestowage plans (which are subject to approval by the MSC) and the ocean shipping documents (manifest, stowage plan, and, if required, hatch lists). Upon receipt of ship loading data from the terminal concerned, the terminal group transmits the cargo traffic message to the discharge port. It also forwards the ship's manifest data to destination by electronic means, airmail, or courier, as appropriate. If more than one loading terminal is involved, each must notify the next terminal of the ship's departure and must manifest the cargo loaded. The last loading terminal prepares the ship's departure message, cargo traffic message, and ship's manifest.

Daily Operations Report

In addition to the documentation required by existing regulations, the terminal group normally requires each terminal battalion operating a port or beach terminal to prepare a daily operations report. This report usually includes the following:

- Number of passengers embarked, debarked, and awaiting embarkation and debarkation; and the number of passengers to be handled during the next 24 hours.

- Number of tons (weight and measurement tons) of cargo by major category (general, vehicles, and POL) that have been discharged, loaded, cleared (by mode) and awaiting discharge, loading, and clearance; and the number of tons booked and expected in the next 24 hours.

- Number of ships which have arrived, departed, remain in port, and are expected to arrive and depart during the next 24 hours; and the status of ships in port, such as discharging, loading, awaiting orders, and under repair.

- Workload for the previous months and anticipated for the next month.

- Summaries of available ship berths, number and capacity of lighters and trucks, number of gangs for ship and pier work, covered and open storage space, number or railroad cars that can be accommodated and cleared, and MHE availability.

FLOATING CRAFT MAINTENANCE

Maintenance and repair of floating craft used in marine terminal operations pose problems and require

arrangements different than from other types of equipment. Except for amphibians and ACVs that can move inland for maintenance work, maintenance and repair facilities for landing craft and other floating equipment must be located afloat or near the water's edge. Rather than being echeloned along the forward theater axis as in other systems, these facilities are generally spread laterally along the theater's rear boundary. Except for some inland waterway systems, marine maintenance and repair facilities are oriented toward the rear.

A marine engineer technician on the terminal battalion staff is responsible for staff supervision of unit maintenance for all marine equipment in the attached companies. This officer supervises correct recording of maintenance activities within the battalion according to existing directives. He also conducts periodic inspections. He prepares reports of inspections, circulates technical information, and provides technical maintenance assistance when required.

A marine maintenance officer provided on the staff of the terminal group and terminal brigade exercises staff supervision over the maintenance function for the command. The commander of the assigned marine DS/GS maintenance unit also acts as a special advisor on floating craft maintenance to the marine maintenance officer and to the terminal group or brigade commander.

Objectives

The objectives of Army watercraft maintenance are as follows:

- Early detection and correction of faults that affect safety afloat.

- Sustainment of an operational readiness posture where this maintenance can be most effectively and economically performed.

More details regarding marine maintenance doctrine can be found in FM 55-50.

Marine Maintenance System

The three-level marine maintenance system provides a flexible, system-oriented supply support structure tailored to the unique character and low density of the single-user Army watercraft fleet. The three levels of watercraft maintenance are marine unit maintenance, marine DS/GS maintenance, and marine depot. All three maintenance levels will be associated with high use of solvents, POL, and other

hazardous materials. Therefore disposal IAW applicable federal, state, local, and HN environmental laws must be planned. Spill contingency plans, emergency materials, and equipment must be maintained.

Marine unit maintenance. This level of maintenance is characterized by rapid turnaround of end items by replacement and minor repair as authorized by applicable maintenance allocation charts. It also provides mandatory parts list stockage and may include direct exchange service. It can be performed entirely by the crew or divided between the crew and a shore-based organizational maintenance section. In the case of landing craft and amphibians, separate TOE sections provide backup shore-based unit maintenance. Tugs, picketboats, floating cranes, and coastal vessels are provided maintenance capacity in single-craft items. Marine unit maintenance functions for these craft are performed entirely by their crews except when grouped into company-size, mission-structure elements. In those instances, unit level, shore-based maintenance cells may be added when required or desired.

Marine DS/GS maintenance. Marine DS/GS maintenance units provide backup supply and maintenance support. They are allocated functions on a return-to-user basis. Maintenance varies for each type of craft due to variances in marine unit maintenance criteria. These units also perform functions considered time-consuming or operationally burdensome for the operating unit. The marine DS/GS maintenance unit provides one-stop support from its base location and forward on-site service via floating maintenance teams. Its maintenance operations are based aboard a floating machine shop located in a harbor or port facility which has a high density of watercraft.

Marine depot maintenance. This level of maintenance is performed by commercial contract, interservice support agreements, or special repair activities. Orientation is toward prompt and effective repair of components and assemblies for return to the supply system. End item overhaul is authorized on a case-by-case basis. During cyclic drydocking, the marine intermediate maintenance facility or unit or contract maintenance inspects, repairs, cleans, and paints the hull.

PERSONNEL MOVEMENT

Personnel moves may consist of casualties or units being deployed or redeployed or may occur as a part of a tactical operation. Personnel moves include inbound (debarkation) and outbound (embarkation) moves.

Inbound (Debarkation)

To plan properly for debarkation and disposition of personnel, the troop movement officer of the terminal group HQ and the commanders of the terminal operating units (battalions and terminal service companies) require certain advance information. This information is obtained from the following:

- Approved movement programs.
- Directives of higher HQ.
- Projected information, such as preembarkation radio messages and lists of personnel waiting in embarkation terminal staging areas for transport to the overseas theater.
- Passenger lists.
- Prearrival information.

The movement programs and projected information enable the troop movement officer and the air, rail, and motor transportation planning officer to make advance plans.

Receipt of the passenger list enables the troop movement officer and others concerned to make specific and detailed plans for receiving incoming personnel. The passenger list provides the name, rank, SSN, shipment number, and organization of all personnel aboard a vessel. This is broken down by units, casualties, officers, warrant officers, enlisted personnel, and civilians. This information is needed for the staging areas to prepare for billeting and messing. The staging area commanders notify the troop movement officer and the terminal operating unit commanders of the location of each unit's billet. The air, motor, and rail transportation planning officers are also given this information. Based on this information and the tentative date of the vessel's arrival, aircraft, trucks, buses, and/or rail equipment can be ordered through the MCC. The information contained in the passenger list is distributed to all other interested agencies.

Usually the last item of advance information needed to permit final planning is an accurate forecast of the

ETA of a vessel. An overseas terminal ordinarily receives this in the radio message sent by the ship's master 24 to 48 hours before the ship's arrival.

Coordination is required, at the terminal command level before actual debarkation, to provide the terminal battalion commander with the information and support for an orderly and efficient debarkation. Agencies and personnel concerned with predebarkation planning and coordination include the following:

- Troop movement officer.
- Movements officer.
- Rail transportation planning officer.
- Air transportation planning officer.
- Highway transportation planning officer.
- Provost marshal.
- Post surgeon.
- Staging area commander.
- Replacement regulating detachment (if casualties are involved).
- Commanders of the terminal operating units assigned this mission.
- MSC representative.
- Items requiring coordination include the following:
 - Vessel's ETA.
 - Exact mission assignment, including the vessel's pier or anchorage and lighterage assignment.
 - Time debarkation is to begin and estimated time hold baggage and other impedimenta will be available.
 - Final arrangements for assigning boarding parties and providing adequate facilities for the use of debarking personnel, the order of debarkation, security measures, the traffic control plan, providing adequate transportation to clear the terminal, designating routes to the staging area, and providing escorts if trucks or buses are used.
 - Special information, if any, which may affect debarkation plans, such as the length of time a vessel can remain at the terminal.

After the necessary coordination has been made, the troop movement officer publishes a debarkation order incorporating all final plans. If the ETA is changed after the debarkation order has been published, the troop movement officer obtains and furnishes a new ETA to all interested personnel as soon as possible.

The actual debarkation is done by the responsible terminal battalion and one or more of its terminal service companies.

Outbound (Embarkation)

Careful consideration is required to ensure an orderly and efficient embarkation. In addition to the personnel listed for debarkation coordination, embarkation coordination also involves representatives from the embarking units and the military departments aboard the vessel(s). Personnel being returned to CONUS must be processed in advance, according to AR 40-12, to meet the requirement of the CONUS quarantine inspection. Personnel must also be processed for CONUS customs inspection.

Problems that must be resolved to provide the operating unit commander and others with required information and support are similar to those incurred in inbound movements. Detailed plans and final arrangements must be completed for the following:

- Composition and designation of the advance party and the time it will embark. These advance details should include mess personnel, kitchen police, guards, and guides.
- Baggage details, arrangements for loading equipment to accompany personnel and any additional equipment that appears on the organizational equipment list. (An officer from each unit or movement order of casualties should be appointed as unit transport baggage officer.)
- Method of transporting personnel from staging area to shipside and schedules showing time of departure of each unit from the staging area and arrival and embarkation times at the pier.
- Detailed traffic control arrangements, including MP to escort truck and bus convoys, if necessary.
- Pier traffic plan.
- Number of gangplanks to be used in the embarkation of each ship.

COMMUNICATIONS

Efficient command and prompt transmission of information and instructions require a reliable signal communications system. When operations are conducted under dispersed conditions, the problem

becomes more complex due to increased distances between the HQ and its subordinate elements. A good communications system within and between ports, depots, beach sites, control points, and other transportation activities is essential. A wire communications system is preferred, particularly in a static situation. However, radio or motorized messenger service may be used.

Coordinating the complex operations for a terminal group to function properly requires early establishment and continued operation of an efficient integrated signal communications network. Communications requirements are developed on a project basis and vary according to the size and composition of the terminal organization and the number of sites operated.

In addition to the communications traffic needed to operate and administer a terminal group and its subordinate units, a requirement may exist for direct visual and radio communications with incoming or outgoing military-operated or military-controlled vessels. This is for information concerning berthing, anchoring, movement, and status or for other operating

instructions or information. When such a requirement exists, it is developed on a project basis. Details involving planning, technical matters, supply, and personnel (including security, training, and operational procedures involving signal equipment and communications systems) are coordinated by the signal officer according to policy established by the commander. The communications officer plans and coordinates the establishment of radio and telephone circuits to and between the terminal group and subordinate battalions. Due to the large volume of traffic generated by subordinate terminal units and the urgency for prompt transmission, total reliance on long signal lines is not feasible.

Good communications must exist within a terminal service company when discharging and/or loading a ship. Hand-held wireless communications are required by hatch crews, crane operators, signalmen, hatch and ship platoon leaders, as well as those on the shoreside facilities. Good communications solve problems much quicker, and the cargo flow is smoother.

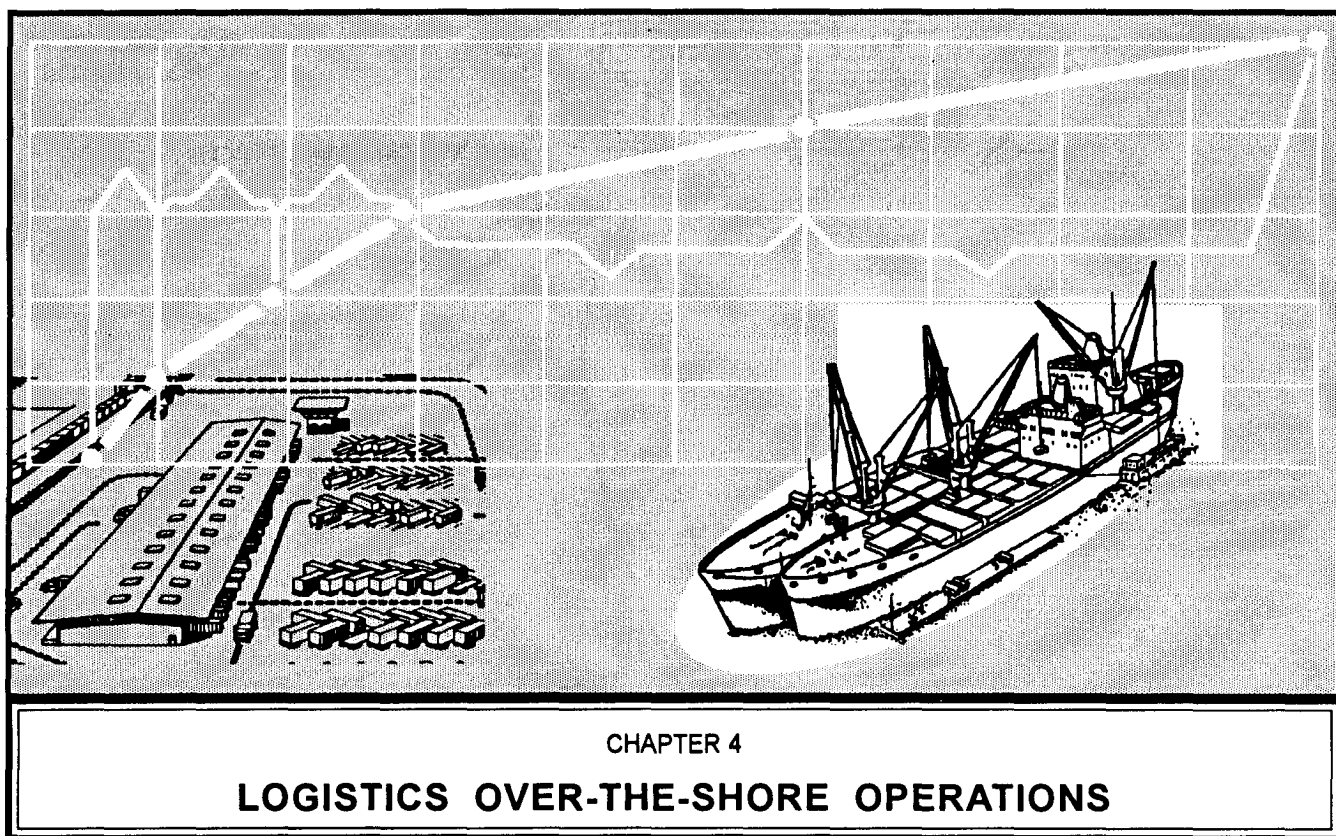

CHAPTER 4

LOGISTICS OVER-THE-SHORE OPERATIONS**INTRODUCTION**

JCS Pub 4-01.6 discusses JLOTS in detail. In overview, an ocean vessel can anchor in the stream or offshore. In-the-stream anchorage means the vessel is anchored in protected deep water, such as a harbor. Offshore anchorage is an anchorage off the shoreline in unprotected deep water. From either anchorage location the ship can discharge to lighterage for subsequent discharge to a fixed-port facility, an unimproved facility, or bare beach. Figure 4-1 (page 4-2) depicts this type of operation.

OPERATION PLANNING

Existing port capacities in many areas are probably insufficient to support theater tonnage requirements.

This, coupled with the possibility of enemy insurgent activities, shifts the emphasis in planning from large port complexes to widely scattered beach-operations. The senior terminal commander in the theater must continually plan and provide for the opening of new beaches to accommodate increased tonnages to replace the tonnage capacity of port or unimproved facilities that enemy actions have made untenable. Plans should include the proposed location and layout of the area, the type of lighterage to be used, and the task organization needed to attain the desired tonnage capacity. They should also include the route and methods of movement to the area, the construction effort required, communications requirements, and logistical support procedures.

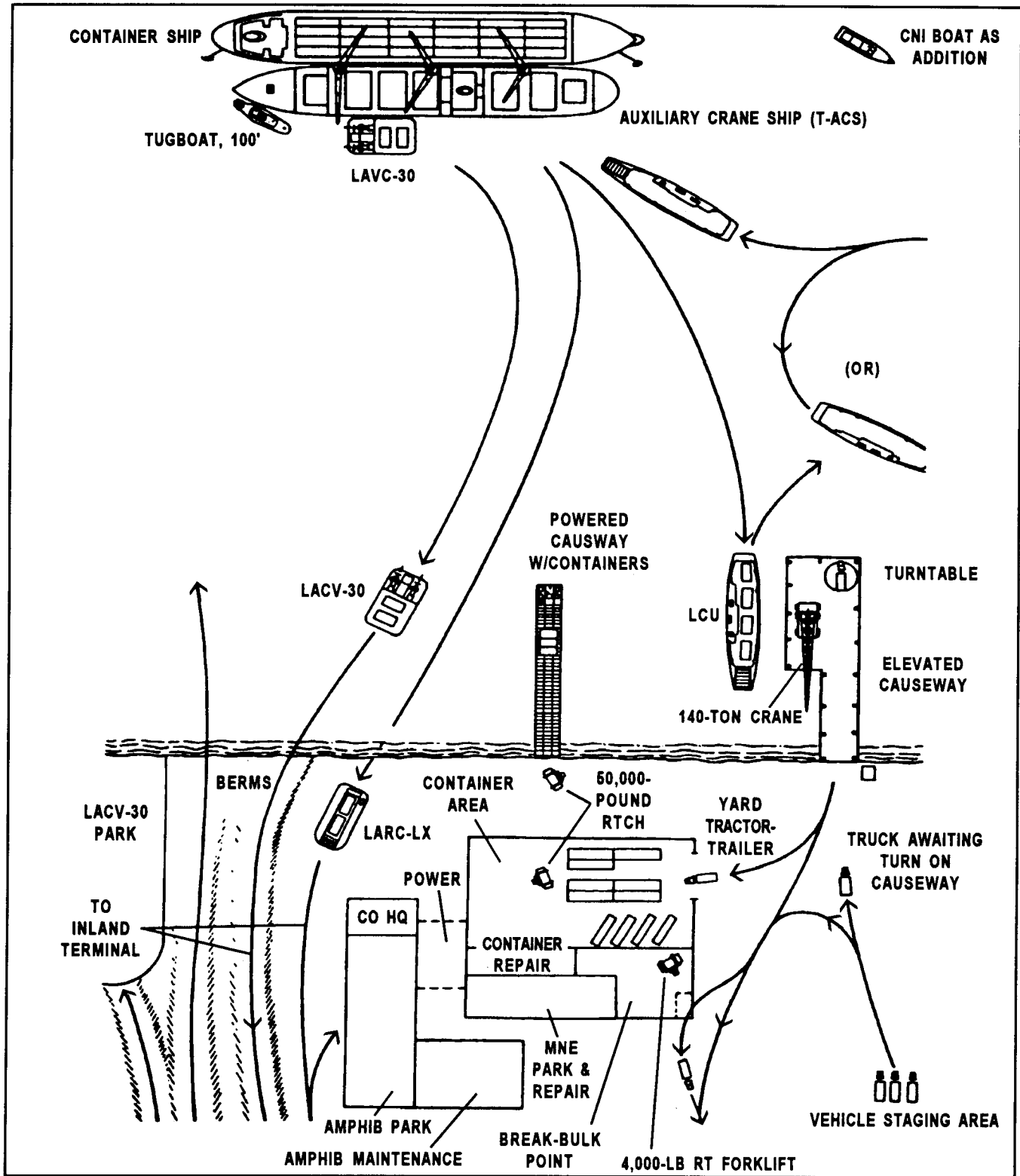

Figure 4-1. LOTS operation

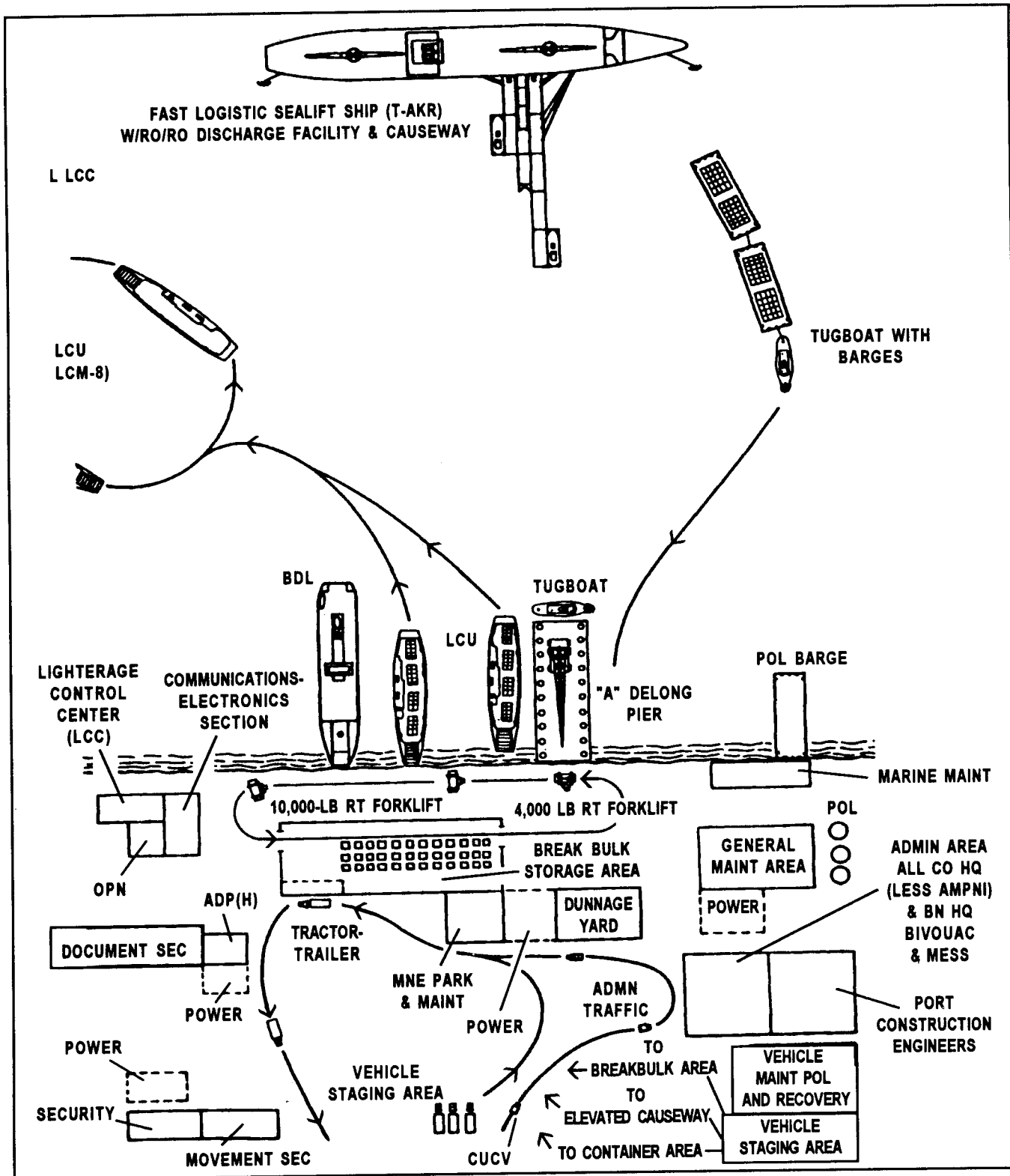

Figure 4-1. LOTS operation (continued)

The first step when planning to open new bare beach LOTS sites is to determine the beach areas available. The degree of dispersion that can be attained, directly relates to the daily tonnage requirement and the size and nature of the assigned area. As soon as practicable after the limiting points of the area have been designated, reconnaissance should be made to determine the sites most suitable for operations. Whenever possible, hydrographic surveys should be conducted at proposed beach landing sites. The selection of these sites should be based primarily on the existing capability to accommodate the desired tonnage. Major factors considered in selecting beach discharge sites include tide, surf, beach gradients, bars, characteristics of the bottom and beach surface, anchorage areas, weather, and topographic features.

The commander should not forget that conducting a LOTS operation almost fully depends on favorable weather. Lighterage operations alongside a vessel are also particularly hazardous if more than a moderate sea is running. Heavy surf reduces the amount of cargo brought in by lighters and could suspend the entire operation.

After the initial reconnaissance is completed and the terminal battalions have been assigned to dispersed sites along the coastline, the terminal group commander must ensure that each battalion has the units, equipment, and other support needed for the assigned mission. Beaches ideally suited for LOTS operations are seldom found without prior preparation or alteration. Therefore, some engineering support is usually required to enable landing craft to beach and to provide exits from the beach to discharge areas and the clearance transportation net.

At each bare beach LOTS discharge point, the beach area operations require close attention and supervision. The success of each beach operation depends on the efficiency of cargo operations on the beach itself. Supplies and equipment being brought to the beach must be kept moving across it toward inland destinations as rapidly as possible. A cluttered beach offers a lucrative target to the enemy and hinders cargo movement. Using amphibians for lightering general cargo and containers greatly helps reduce beach congestion.

Employing terminal units over widely separated distances along a coastline requires careful evaluation of the maintenance system supporting a scattered operations complex. When operations are conducted in a

dispersed situation, emphasis on organizational maintenance must be increased. Unit maintenance personnel should be well trained. Every effort must be made to fix minor troubles to prevent costly equipment breakdowns. The terminal group SOP should establish the procedure for maintenance support. Floating craft maintenance units supporting terminal operations over an extended length of coastline require mobile marine repair facilities and on-site repair service.

In dispersed beach terminal operations, all terminal units, operating equipment, cargo, and facilities are as widely separated as operational efficiency permits. Personnel, materials, establishments, and activities are spread over a wide area to avoid offering the enemy a concentrated target. Discharge operations are scheduled to limit offering a lucrative target to the enemy to as short a time as possible.

Dispersion of terminal units greatly increases reliance on radio communications for effective command, control, and coordination. Therefore, COMSEC and ECCM become more critical to maintaining reliable communications.

Each two-ship terminal is under the direct operational supervision of a terminal battalion. Each terminal is manned by one terminal service company and lighterage units commensurate with the workload and environment. One or more medium truck companies may also be attached for intraterminal transportation and clearance assistance. Terminal transfer elements may need to help clear excessive cargo backlogs in discharge areas. Harborcraft teams may also be attached as required. A terminal group coordinates the functions of a number of these terminals, dispersed along a maximum of 150 miles of shoreline. Maintenance for the employed lighterage is provided at group level.

In addition to the environmental factors outlined in this chapter, the same planning considerations and operational functions and procedures described in Chapter 3 must be provided for and carried out by the terminal organizations assigned to conduct LOTS operations.

RECONNAISSANCE AND SITE SELECTION

Normally, the terminal commander in consultation with naval authorities initially selects possible beach sites for LOTS operations. This is done from an

extensive study of maps and hydrographic charts and from an analysis of aerial reconnaissance reports. A detailed ground and water reconnaissance of the selected area, as thorough as time and the situation permits, finally determines the feasibility of operations at these sites. Aerial reconnaissance helps to verify information obtained from the map reconnaissance. Road nets shown on the map may have been destroyed or made impassable. New roads may have been built. Bridges may have been destroyed or structures may have been built on the beach. Naval authorities must be consulted early in the study so that advice about possible anchorage areas and difficulties and hazards to navigation will be available as early as possible.

The party that conducts the ground and water reconnaissance must include personnel that can advise the terminal commander of various matters. These matters include the following:

- The engineering effort required to prepare and maintain the area.
- Signal construction and maintenance required for communication within the beach area and between the beach area and the terminal HQ.
- Environmental considerations to include the location of beach dumps, transfer points, and maintenance areas.
- The type of lighterage that could be employed most effectively.
- The need for and location of safe-haven facilities for lighterage.
- The location and desirability of anchorage areas.
- The possibility of using spud (self-elevating, nonpropelled) piers and other special equipment.
- The vulnerability to enemy attack of the terminal area, its seaward approaches, and its connections with the interior.
- The proximity and capacity of road and rail networks.

The typical reconnaissance party should consist of, but not be restricted to the following:

- Representatives of the terminal commander to coordinate or supervise the reconnaissance team and to recommend task organization.
- The terminal battalion commander and appropriate members of his staff.
- An engineer officer, preferably from the supporting engineer unit.

- A signal officer, preferably from the supporting signal unit.

- Representatives of amphibian units to locate desirable entrances to and exits from the water and transfer points.

- Representatives of landing craft units to select beach areas, anchorages, maintenance areas, and navigation aids.

- Representatives of units with special equipment to be used.

- Naval representatives to advise on anchorage areas, naval support required, and harbor security.

- US Coast Guard representatives to advise on port security.

- An MP representative to determine the needs and plan for providing MP support required for traffic control and beach management.

In addition to gauging beach area characteristics, the reconnaissance party must determine if the beach area selected has enough anchorage to accommodate the number and types of ships required to support the planned beach operations. If the naval representative has indicated that the anchorage areas are acceptable to the Navy, they must be examined to determine whether the lighterage to be used can traverse the area between the anchorage areas and the beach. For example, sandbars or reefs just offshore may preclude the use of LCMs, LCUs, or barges in certain areas. They may also require the use of amphibians until a channel can be cleared. Among the salient features to be considered are the following:

- Depth. For large cargo ships, a MLW of 30 feet and a maximum of 210 feet are required. A FSS requires a MLW of 37 feet. The maximum draft of ships to be discharged and the ground swells dictate the minimum depth.

- Size. For planning purposes, the anchorage area should be a circle with an 800-foot radius to provide a safe, free-swinging area. This is required for the standard five-hatch vessel. Use the following formula if larger vessels are anticipated in the operation.

$$2(7D + 2L) = \text{diameter in feet}$$

Where:

D = depth of water in feet

L = length of vessel in feet

NOTE

A much larger radius may be required for dispersion if operations are being conducted under threat of nuclear warfare or if hazardous materials are included. Bow and stern mooring is not considered desirable in tidal areas because athwartship currents excessively strain mooring gear. Appreciable changes in depth also requires continuous watching of the anchored vessels. The type of offshore bottom also significantly affects how close ships can be anchored to each other. A ship will drag anchor if the bottom is too rocky or slushy.

□ Landmarks. Landmarks, especially those assisting navigation and location of beaches (such as prominent hills) are helpful.

□ Underwater obstacles. Underwater obstacles such as bars, shoals, reefs, rocks, wrecks, and enemy installations that might interfere with the passage of vessels to and from the area should be noted. The degree of interference offered and the amount of work involved in clearing channels should be estimated.

During the reconnaissance, the terminal battalion commander also selects and assigns company areas and frontages, indicates areas of defense responsibilities, and tentatively organizes the AO. Upon completion of the reconnaissance, the findings are analyzed and the most desirable beach areas are selected. Alternate beaches are chosen and listed in order of suitability. The battalion commander submits the selected sites to the terminal group commander with a written plan for implementing operations at the selected beach.

BEACH CAPACITY

For general planning, beach capacity may be determined by applying the data in FM 101-10-1/1. However, these data are based on average conditions and must be adapted to a specific beach operation. Several factors must be considered to determine the capacity of a particular discharge site. These factors can be divided into the following three groups:

□ Those that limit the discharge rate from the vessel instream.

□ Those that limit the cargo-handling capacity of the beach.

□ Those that restrict the flow through the area because of the nature of the beach and the hinterland.

The group of factors that most limit the quantity of supplies that can be handled determines the capacity of the beach. Beach terminal planning requires making a beach capacity estimate. It involves the same steps that are used in planning for a fixed marine terminal. Table 4-1 and Figures 4-2 and 4-3 provide essential information and definitions relative to this estimation.

Factors Affecting Handling Capacity

Factors affecting cargo-handling capacity include the following:

□ Numbers and experience of personnel available for discharging ships and handling cargo on the beach and in the discharge areas.

□ Type and availability of MHE and transportation equipment for beach clearance.

□ Types and amounts of lighterage available for operations.

□ Enemy's ability to interrupt operations.

Table 4-1. Beach gradients

DESCRIPTION	GRADE (IN FEET)
STEEP	MORE THAN 1 IN 15
MODERATE	1 IN 15 TO 1 IN 30
GENTLE	1 IN 30 TO 1 IN 60
MILD	1 IN 60 TO 1 IN 120
FLAT	LESS THAN 1 IN 120

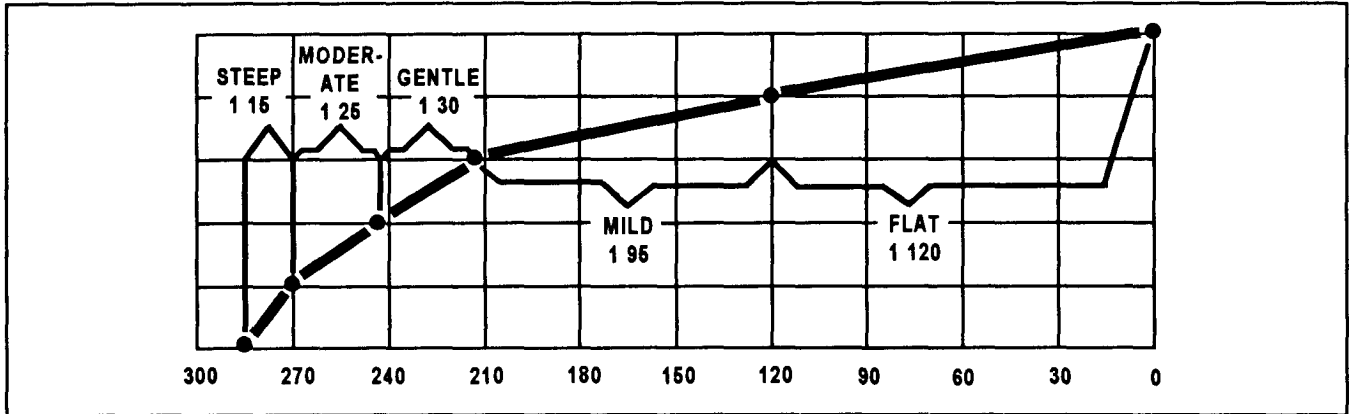

Figure 4-2. Profile view of underwater gradient

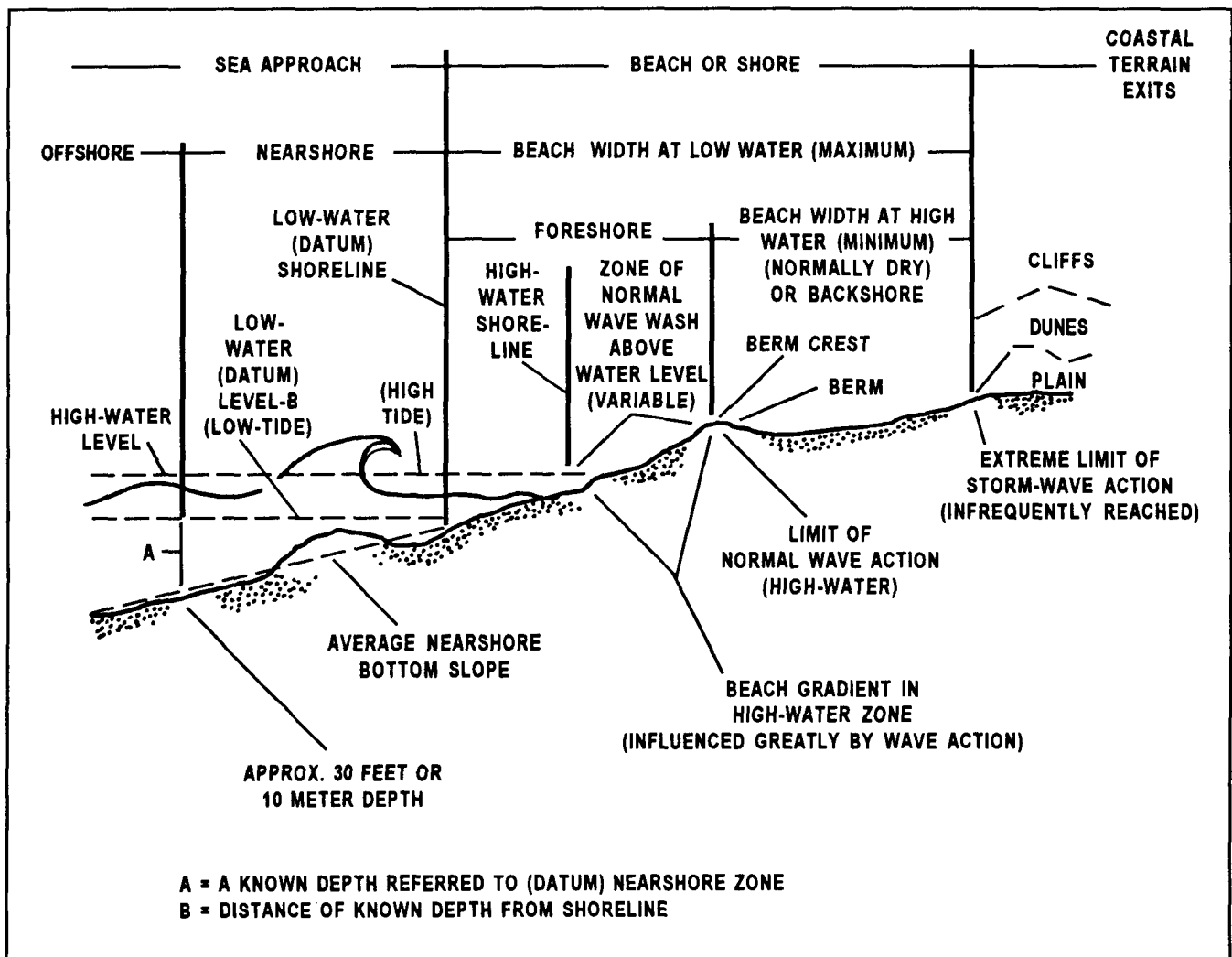

Figure 4-3. Marine beach profile diagram

Limitations Imposed by Terrain

Most of these factors are self-explanatory, but since beach exits and the nature of the hinterland play such important roles in beach capacity, they are discussed in detail. Possible limitations include the following:

- The length and width of the beach.
- Underwater obstacles.
- The tidal range.
- The strength and direction of the tidal stream (rip currents and littoral currents).
- The surf.
- The gradient of the beach as it affects the landing of lighterage and the movement of supplies across the beach proper.
- The bearing surface of the beach.
- The availability and nature of beach exits.
- The nature of the hinterland.
- The weather.

Beach Exits

Often the capacity of the road net, from the beach to principal inland areas, limit the capacity of a beach to discharge and clear supplies and personnel to inland destinations. The useful capacity of the beach can never exceed the capacity of the road net. Therefore, an early and detailed analysis must be made to determine the capacity of the existing road net. If the capacity is inadequate, new roads must be built. This requires additional engineer support for construction and maintenance.

The number of exits required varies according to the physical characteristics of the roads, the type and amount of cargo to be handled, and the type of conveyance to be used in beach clearance. Tracked and wheeled vehicles should have separate routes.

The nature of the area next to the beach may limit the number of possible exits from the beach. An otherwise ideal beach may be backed by sand dunes, seawalls, swamps, or other obstacles that hamper beach clearance operations.

Hinterland

In selecting a beach for unloading cargo, the reconnoitering officer must consider more than the beach and its exits. He must consider the availability of a road or rail net or the possibility of building one to tie the beach exits to the main transportation net. He must also consider the existence of or need for telephone

and telegraph lines, radio stations, and power lines. Finally, the availability of inland waterways must be evaluated. If suitable roads exist, thorough reconnaissance should be made to determine their exact physical characteristics. The strength and width of any bridges in a road net are of prime importance in evaluating capabilities or limitations. Since helicopters may be used for clearance operations, the reconnoitering officer should consider a suitable area for establishing a heliport.

BEACH TRANSFER POINTS

The requirement for beach transfer points must be considered during the reconnaissance and their locations should be designated. A desirable beach transfer point should include the following:

- Be located to the rear of the beach so as not to interfere with shoreline operations.
- Be on the route the amphibians use to move from and to the water.
- Be near the clearance route for the beach where cargo trucks moving in the traffic pattern can receive their load without interference with other traffic and still have access to and exit from the transfer points.
- Be so selected that the amphibians will cross the beach and make it unnecessary to prepare a beach roadway for the cargo trucks.
- Be near a railhead, if rail is an active mode.
- Have room for a roadway on either side of the MHE operating at the transfer point so that there is no interference between the amphibian and the cargo truck.
- Have cranes located on firm, level ground. The crane's longer axis should be parallel to the direction of movement of the vehicles. With the crane in this position, loads can be transferred with the least amount of movement of the boom.

TEMPORARY HOLDING AREAS

In general, the problems of cargo clearance in beach operations are the same as for conventional port terminals. However, differences in the physical characteristics of the operating areas may require the modification of procedures and the use of different types of equipment. In an ideal situation, clearance

transportation capacity equals the discharge capability and cargo is moved through and out of the terminal area as fast as it is unloaded from the ships. However, this balance seldom occurs. Some cargo backlog must be anticipated and provided for by establishing temporary in-transit storage areas. These areas should be near the transfer point used by amphibians to hold cargo that cannot be immediately transferred to clearance conveyances. Cargo unloaded from landing craft that cannot be immediately cleared should also be brought to these in-transit storage areas to avoid congestion and cargo pileup on the beach.

When clearance transportation later becomes available to move this cargo from the in-transit storage areas, terminal service companies will outload cargo from in-transit storage. Should cargo staged in the in-transit storage area become excessive, any effort diverted by these units to handle this cargo would impair the unit's ability to keep the lighters moving. If this practice continues, the entire operation stagmates. This problem is solved by temporarily assigning terminal transfer elements (squads, platoons, or companies) to load backlogged or frustrated cargo in the in-transit storage area onto clearance transportation. This maintains the flow of cargo out of the terminal without disrupting the discharge operations at the ship by slowing lighter turnaround.

Temporary in-transit storage areas should be located away from main clearance roads to minimize road congestion and to present less lucrative targets. Roads leading from the main clearance roads to the in-transit storage areas must be kept in good condition. Each area should have a separate entrance and exit. If tracked vehicles are to be used as well as trucks and amphibians, separate traffic nets may be needed. The ground should be level, firm, and dry. The surrounding area should be large enough so that in-transit storage facilities can be expanded to meet anticipated maximum requirements.

TRAFFIC CONTROL

Traffic control is vital to preventing congestion in the terminal area and promptly clearing cargo

to its initial destination. To control vehicle traffic in a beach area, make sure of the following:

- A sufficient number of drivers, MHE, and supervisors should be available for around-the-clock operations.
- A one-way traffic system should be established to alleviate congestion.
- Use of motor transport equipment should be carefully planned for maximum use (see FM 55-30).
- Vehicles should be loaded to capacity whenever this practice is consistent with cargo segregation requirements.
- Control procedures should be set up to provide readily available information on the location and current employment of all motor transport facilities. This is done so that equipment or units can be promptly diverted with minimum disruption of the overall operation.

BEACH MANAGEMENT

The requirements for clearing personnel, supplies, and equipment from beaches usually exceed available capacity. Careful planning and close supervision are needed to maximize the use of available equipment, personnel, and facilities. Some measures that help to clear supplies and equipment from the beach area include the following:

- Using amphibians to the maximum extent.
- Continuously improving the beach (in general) to increase overall operational capacity and efficiency.
- Planning the handling of peak workloads without disrupting operations.
- Maintaining close liaison and coordination with cargo transfer points and temporary holding areas so as not to exceed their receiving capacities and yet maintain a near-capacity flow of cargo to them.
- Separating landing points for amphibians and landing craft to prevent clearance conflict.
- Holding documentation, records, and reports to a minimum.
- Locating beach parking areas for MHE and clearance vehicles in areas readily accessible to discharge points.
- Adopting an enforced traffic circulation plan to avoid conflict in the flow of traffic.

- Locating bivouac area and messing areas so as to avoid loss of time in moving personnel to and from working points.

- Adopting alert systems and defense plans to prevent a surprise enemy attack and to enable the terminal to maintain an adequate defense.

UNLOADING OPERATIONS

During unloading operations, terminal service company personnel should be alert for new ways to expedite cargo movement. Some practical expedients are discussed below.

- When barges are used in the discharge operations, stowing cargo aboard and moving cargo to the hook or fixed or mobile shore-based cranes may be a problem. Using forklift trucks aboard a barge and a crawler crane alongside on a separate barge will facilitate operations.

- Normally, rough terrain cranes are needed at the shoreline when cargo must be lifted from landing craft and placed in highway transport equipment.

- FCs, RO/RO platforms, and powered causeways are used to ensure motor vehicles safely reach the beach. They will also eliminate the possibility of drowning out because vehicles can roll ashore without passing through the water.

Each terminal service company operation site should have at least one truck dispatcher when clearance is being done by trucks. The dispatcher uses DD Form

1384 to back up his dispatch slip. The dispatch slip shows the destination of the load. He can thus dispatch loaded trucks immediately, saving time and avoiding the congestion that might result if only one dispatch point were in the battalion area. If movement by convoy is dictated, the formation of convoy serials is expedited due to the faster rate of dispatch of single vehicles to make up these serials (see FM 55-30).

SHORE-TO-SHORE OPERATIONS

Tactical and logistical shore-to-shore operations may be conducted across or along rivers, between islands, along a coastline, or between a continental land mass and an offshore island. Except for the fact that ocean shipping is not involved, terminal unit functions in these operations are the same as described for bare beach and amphibious operations. In a shore-to-shore assault, terminal organizations are attached to the combat unit conducting the operations. They provide the same support as described in previous chapters. Command elements and relationships in logistical shore-to-shore operations are the same as in conventional marine terminals and in ship-to-shore bare beach LOTS operations. The terminal service company ship platoons work in the loading area on the near shore, and the shore platoons operate discharge points in the objective area. Amphibian and landing craft units provide the lighterage service. Terminal transfer elements may be assigned to clear cargo backlogs.

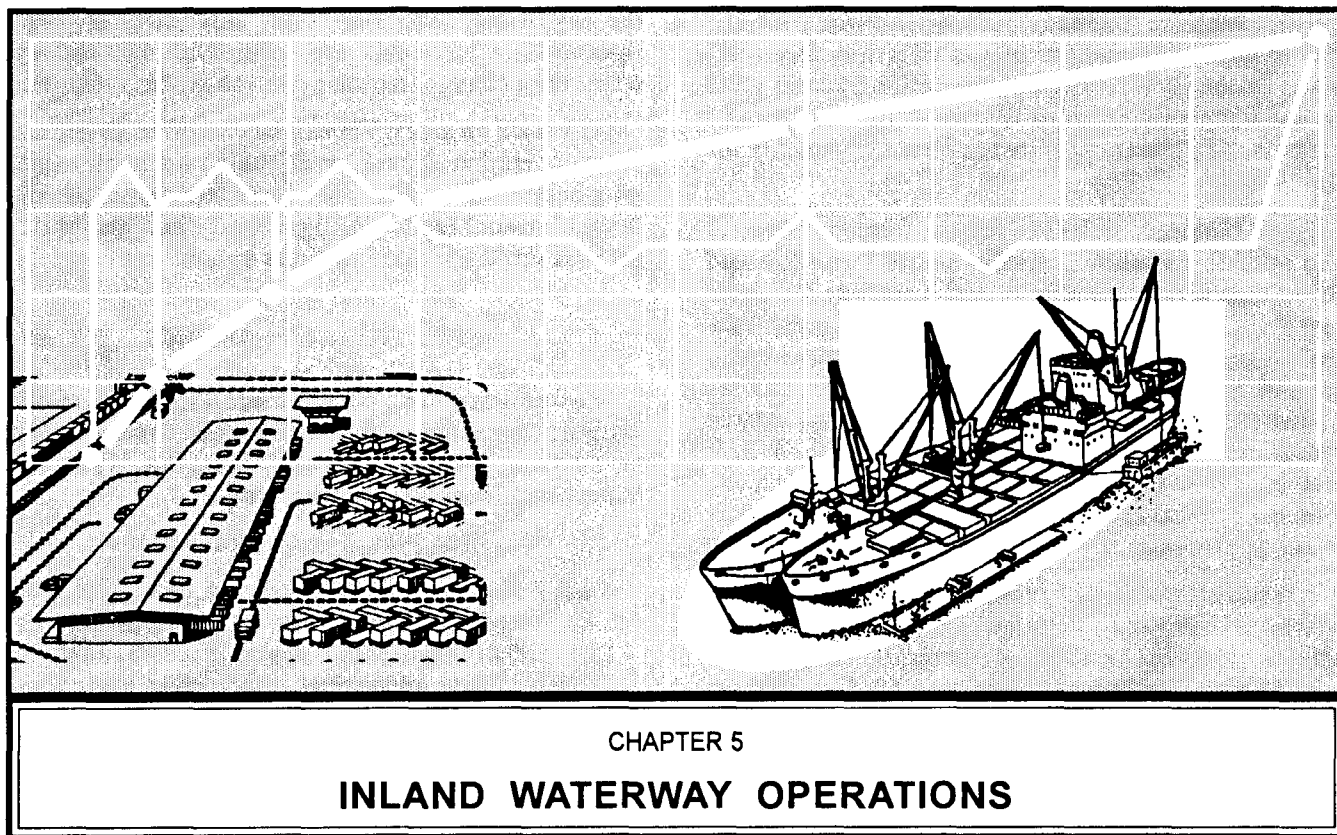

This chapter implements QSTAG 692.

INTRODUCTION

Inland waterways include all rivers, lakes, inland channels, canals deep enough for waterborne traffic, and protected tidal waters. In a TO, an inland waterway is normally operated as a complete system. It includes the locks, dams, bridges, and other structures that contribute to or effect movement of vessels carrying passengers and freight. Inland waterways are mainly used for the civilian economy. Military use depends on the degree of waterway development, necessary rehabilitation, tactical situation, and the impact military use of the waterway will have on the civilian economy. It is an extremely efficient method for moving liquid, bulk, or heavy or outsized cargo where there is an abundance of navigable rivers and canals and lack of good and/or available roads and railroads.

QSTAG 592 (see Appendix B) standardizes documents common to several means of transport. This agreement helps the terminal operators predict movement requirements.

INLAND WATERWAY SYSTEM

The US Army Corps of Engineers operates and maintains the IWWS in a generic theater or in CONUS. In overseas theaters that have developed IWWSs, the HN operates and maintains them. The US Army's use of the system must be granted by the HN. Once the HN has approved integration of the US Army into its IWWS, equipment requirements, including equipment allocated by the HN, must be determined.

Three separate functional components (the ORP, the inland waterway, and the inland waterway terminal) make up the IWWS. The transportation planner must estimate the capacity of each of these functional components. The lesser capacity becomes the capacity for the IWWS.

When required, an IWWS may be formed to control and operate a waterway system and to formulate and coordinate plans for using inland waterway transport resources. It may also be formed to provide for integrating and supervising local civilian facilities used to support military operations. Depending on the requirements, this operational organization may vary in size from a single barge crew to a complete IWWS. It may consist entirely of military personnel or may be manned by local civilians supervised by military units of the appropriate transportation staff section.

A terminal group may operate an IWWS. However, a terminal battalion composed of appropriate terminal service, terminal transfer, harborcraft, boat, and/or amphibian units is most often employed in this capacity. Figure 5-1 shows a typical inland waterway organization.

INLAND WATERWAY TERMINAL

An IWWT normally includes facilities for mooring, cargo loading and unloading, dispatch and control, and repair and service of all craft that can navigate the waterway. Terminals either exist or are established at

the origin and terminus of the inland water route. Intermediate terminals are located along the way, wherever a change in transportation mode is required.

Terminals on an IWWS can be classified as general cargo, container, liquid, or dry bulk commodity shipping points. Terminals of the three latter types usually include special loading and discharge equipment that permits rapid handling of great volumes of cargo.

OPERATIONAL PLANNING

The transportation planner is interested in an inland waterway's capability to move cargo. Consequently, he is interested in the affect of the waterway's physical features on its ability to carry cargo.

Physical Planning Considerations

Among the physical features that determine what can be moved over a waterway are the following:

- Restricting width and depth of the channel.
- Horizontal and vertical clearance of bridges.
- Number of locks, their method of operation, and the length of time required for craft to clear them.

Freeze-ups, floods, and droughts also affect a waterway's capacity. The transportation planner must know when to expect these seasonal restrictions and how long they can be expected to last. He is concerned with speed, fluctuation, and direction of water current; as well as the availability of craft, labor, terminal facilities, and maintenance support.

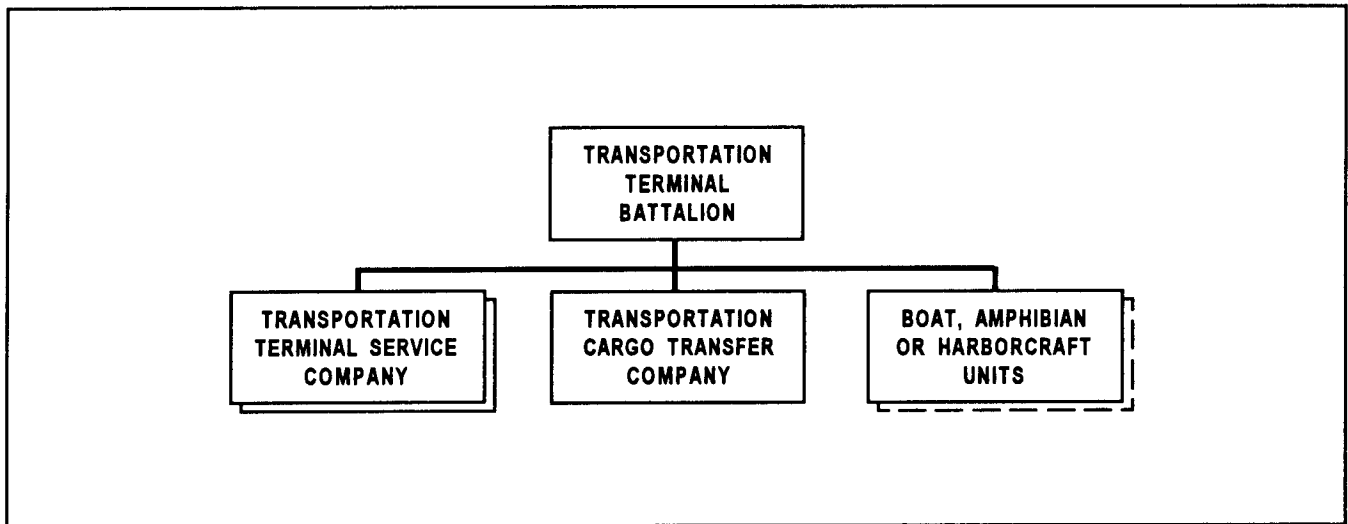

Figure 5-1. Sample organization for IWWS

Seldom are enough craft or barges available to fill or exceed the capacity of an inland waterway. However, if there are enough, the daily capacity can be estimated. This is done by determining the number of craft per day that can be passed through the most limiting restriction, such as a lock, lift bridge, or narrow channel. This will give a passage capability. Deduct the civilian passages and that leaves the passages allowed the military. (A percentage may be allowed instead.)

Turnaround time is the length of time between leaving and returning to a point. Since barges are being picked up at a wharf or stake barge, barge loading time is not part of the computation. If barges are picked up at shipside without marshaling at a wharf or stake barge, loading time of the barge would become a factor of turnaround time. The paragraphs below discuss items that must be known to calculate turnaround time.

□ Length of haul is the round-trip distance between the barge pickup point and barge delivery points.

□ Speed is influenced by the wind, current, power of craft, and size of load. If the craft's speed cannot be determined, assume it is 4 miles per hour in still water (6.4 kilometers per hour). Speed and direction of current can frequently be discounted since resistance in one direction may be balanced by assistance in the other direction. However, this is not always the case.

□ Loading and unloading time is the time to load and unload a craft at origin and destination.

□ Time consumed in the locks is the time taken by a craft and its tow to pass through a lock. When exact data is lacking, lock time is assumed to be 1 hour per single lock.

□ Planned hours of operation per day is usually 20. Dropping barges from the tow, refueling, taking on stores, rigging up, and maintenance consume the remaining 4 hours.

□ Transit time is the time to move the craft the length of the haul and return to its origin. Transit time equals the distance divided by the speed of the craft. It does not include stops or delays of any kind. Due to possible damage to the inland waterway, a speed control may be in force. To determine transit time, add the following:

- The time to make up the tow.
- The distance divided by the speed of the tow.
- The time consumed passing through the locks.
- The time to break up the tow.

When determining the number of barges, tugboats, or craft required, always round up to the nearest whole number, then apply maintenance factor and round up again.

The most current type of barge employed is when LASH and SEABEE type ships are used. These ships furnish preloaded barges. Therefore, the barges used on the IWWS are furnished by the ship schedules. On an inland waterway, one of two possible situations will determine the method for calculating the waterway capacity.

Required information is needed for planning for turnaround times and equipment requirements when employing barge-carrying ships. Table 5-1 (page 5-4), contains criteria for determining planning and equipment requirements for barge-carrying ships.

Required information is needed when barge-carrying ships are not in use and ship's cargoes are discharged onto barges at the ORP. Table 5-2 (page 5-5) contains criteria for bargecarrying ships that are not in use.

Because of the many possible variables in this type of an operation, the given situation must be evaluated instead of using a simple formula. Factors that must be considered include the following:

- Number of barges required daily at the ORP.
- Number of barges required daily at the IWWT.
- Number of barges in transit daily on the IWWS.
- Frequency of berth vacant time at the ORP.
- Length of berth vacant time at the ORP.
- Maintenance factor for barges.
- Surge for barges for peak periods.

IWWT Capacity

Appropriate terminal service units or teams staff inland waterway terminals. The number of units required depends on the results of an IWWT throughput analysis. An analysis is conducted for each IWWT in the IWWS. The combined capacity of the IWWTs is the cumulative total of the restricting capacity (reception capacity, discharge capacity, or clearance capacity) for each IWWT. There may be a requirement for tugboats stationed at the IWWTs to make up/breakup tows and to shift barges between terminals and an additional mooring area. The additional mooring area may be required to allow a buildup of barges to keep an even flow of barges at the terminals.

Table 5-1. Determining factors when using barge-carrying ships

FACTORS			
<ul style="list-style-type: none"> • Terminal workdays devoted to shipload of cargo: $G = \frac{D \quad E \quad F}{A + B + C}$ • Barges required at the IWWT daily: $H = \frac{J}{G}$ • Number of tows required at the IWWT daily: $K = \frac{H}{L}$ • Number of tows one tug can deliver daily: $M = \frac{N}{P}$ 	<ul style="list-style-type: none"> • Number of tugboats required to deliver tows: $Q = \frac{K + a}{M}$ • Transit time for tugboats: $R = \frac{S + T + U + W}{V}$ • Turnaround time for a tugboat in hours: $P = 2R$ • Turnaround time for shipload of barges: $Y = Z + G + P$ 		
<p>LEGEND:</p> <table style="width: 100%; border: none;"> <tr> <td style="width: 50%; vertical-align: top;"> <p>A = IWWT daily discharge rate for containers</p> <p>B = IWWT daily discharge rate for general cargo</p> <p>C = IWWT daily discharge rate for heavy containers</p> <p>D = total containers on shipload of barges</p> <p>E = total general cargo on shipload of barges</p> <p>F = total heavy lifts on shipload of barges</p> <p>G = IWWT workdays devoted to shipload of barges</p> <p>H = barges required at the IWWT daily</p> <p>J = total number of barges on shipload</p> <p>K = number of tows required at the IWWT daily</p> <p>L = number of barges per tow</p> <p>M = number of tows one tug can deliver per day</p> <p>N = operational hours per day</p> </td> <td style="width: 50%; vertical-align: top;"> <p>P = turnaround time for a tugboat in hours</p> <p>Q = number of tugboats required to deliver tows</p> <p>R = transit time for tugboats</p> <p>S = time to makeup a tow of barges and tugboat</p> <p>T = traverse time of locks</p> <p>U = distance from ORP to IWWT</p> <p>V = average speed of tows</p> <p>W = time to break up a tow of barges and secure</p> <p>Y = turnaround time for shipload of barges</p> <p>Z = ship discharge and processing time of first and last tow</p> <p>a = maintenance factor for tugboats</p> </td> </tr> </table>		<p>A = IWWT daily discharge rate for containers</p> <p>B = IWWT daily discharge rate for general cargo</p> <p>C = IWWT daily discharge rate for heavy containers</p> <p>D = total containers on shipload of barges</p> <p>E = total general cargo on shipload of barges</p> <p>F = total heavy lifts on shipload of barges</p> <p>G = IWWT workdays devoted to shipload of barges</p> <p>H = barges required at the IWWT daily</p> <p>J = total number of barges on shipload</p> <p>K = number of tows required at the IWWT daily</p> <p>L = number of barges per tow</p> <p>M = number of tows one tug can deliver per day</p> <p>N = operational hours per day</p>	<p>P = turnaround time for a tugboat in hours</p> <p>Q = number of tugboats required to deliver tows</p> <p>R = transit time for tugboats</p> <p>S = time to makeup a tow of barges and tugboat</p> <p>T = traverse time of locks</p> <p>U = distance from ORP to IWWT</p> <p>V = average speed of tows</p> <p>W = time to break up a tow of barges and secure</p> <p>Y = turnaround time for shipload of barges</p> <p>Z = ship discharge and processing time of first and last tow</p> <p>a = maintenance factor for tugboats</p>
<p>A = IWWT daily discharge rate for containers</p> <p>B = IWWT daily discharge rate for general cargo</p> <p>C = IWWT daily discharge rate for heavy containers</p> <p>D = total containers on shipload of barges</p> <p>E = total general cargo on shipload of barges</p> <p>F = total heavy lifts on shipload of barges</p> <p>G = IWWT workdays devoted to shipload of barges</p> <p>H = barges required at the IWWT daily</p> <p>J = total number of barges on shipload</p> <p>K = number of tows required at the IWWT daily</p> <p>L = number of barges per tow</p> <p>M = number of tows one tug can deliver per day</p> <p>N = operational hours per day</p>	<p>P = turnaround time for a tugboat in hours</p> <p>Q = number of tugboats required to deliver tows</p> <p>R = transit time for tugboats</p> <p>S = time to makeup a tow of barges and tugboat</p> <p>T = traverse time of locks</p> <p>U = distance from ORP to IWWT</p> <p>V = average speed of tows</p> <p>W = time to break up a tow of barges and secure</p> <p>Y = turnaround time for shipload of barges</p> <p>Z = ship discharge and processing time of first and last tow</p> <p>a = maintenance factor for tugboats</p>		

Table 5-2. Determining factoring when not using barge-carrying ships

FACTORS			
<ul style="list-style-type: none"> • Daily barge loading rate at the ORP: $A = B \times C$ • Barges loaded daily at the ORP: $D = \frac{A}{E}$ • Daily barge requirement at the ORP: $F = D + G$ • Daily barge discharge rate of the IWWT: $H = J \times K$ • Barges discharged daily at the IWWT: $L = \frac{H}{E}$ • Daily barge requirement at the IWWT: $M = L + G$ 	<ul style="list-style-type: none"> • Daily tows required at the ORP: $N = \frac{F}{Q}$ • Daily tows required at the IWWT: $P = \frac{M}{Q}$ • Turnaround time of tugboat: $R = 25$ • Number of tows a tugboat can deliver daily: $T = \frac{U}{R}$ • Number of tugboats required to deliver tows: $V = \frac{N \text{ or } P^*}{T + W}$ • Number of barges required for the IWWS. 		
<p>LEGEND:</p> <table style="width: 100%; border: none;"> <tr> <td style="width: 50%; vertical-align: top;"> <p>A = daily barge-loading rate at the ORP</p> <p>B = number of barge-loading berths at the ORP</p> <p>C = daily loading rate per barge berth at the ORP</p> <p>D = barges loaded daily at the ORP</p> <p>E = average barge cargo capacity</p> <p>F = daily barge requirement at the ORP</p> <p>G = barge maintenance factors (round up)</p> <p>H = daily barge discharge rate at the IWWT</p> <p>J = number of barge discharge berths at the IWWT</p> <p>K = daily discharge rate per barge berth at the IWWT</p> <p>L = barges discharged daily at the IWWT</p> </td> <td style="width: 50%; vertical-align: top;"> <p>M = daily barge requirement at the IWWT</p> <p>N = daily tows required at the ORP</p> <p>P = daily tows required at the IWWT</p> <p>Q = barges per tow</p> <p>R = turnaround time of a tugboat in hours</p> <p>S = transit time for tugboat</p> <p>T = number of tows a tugboat can deliver daily</p> <p>U = operational hours per day</p> <p>V = number of tugboats required to deliver tows</p> <p>W = tugboat maintenance factor (round up)</p> <p>Y = number of barges required for the IWWS</p> </td> </tr> </table> <p>*largest of the two (N or P)</p>		<p>A = daily barge-loading rate at the ORP</p> <p>B = number of barge-loading berths at the ORP</p> <p>C = daily loading rate per barge berth at the ORP</p> <p>D = barges loaded daily at the ORP</p> <p>E = average barge cargo capacity</p> <p>F = daily barge requirement at the ORP</p> <p>G = barge maintenance factors (round up)</p> <p>H = daily barge discharge rate at the IWWT</p> <p>J = number of barge discharge berths at the IWWT</p> <p>K = daily discharge rate per barge berth at the IWWT</p> <p>L = barges discharged daily at the IWWT</p>	<p>M = daily barge requirement at the IWWT</p> <p>N = daily tows required at the ORP</p> <p>P = daily tows required at the IWWT</p> <p>Q = barges per tow</p> <p>R = turnaround time of a tugboat in hours</p> <p>S = transit time for tugboat</p> <p>T = number of tows a tugboat can deliver daily</p> <p>U = operational hours per day</p> <p>V = number of tugboats required to deliver tows</p> <p>W = tugboat maintenance factor (round up)</p> <p>Y = number of barges required for the IWWS</p>
<p>A = daily barge-loading rate at the ORP</p> <p>B = number of barge-loading berths at the ORP</p> <p>C = daily loading rate per barge berth at the ORP</p> <p>D = barges loaded daily at the ORP</p> <p>E = average barge cargo capacity</p> <p>F = daily barge requirement at the ORP</p> <p>G = barge maintenance factors (round up)</p> <p>H = daily barge discharge rate at the IWWT</p> <p>J = number of barge discharge berths at the IWWT</p> <p>K = daily discharge rate per barge berth at the IWWT</p> <p>L = barges discharged daily at the IWWT</p>	<p>M = daily barge requirement at the IWWT</p> <p>N = daily tows required at the ORP</p> <p>P = daily tows required at the IWWT</p> <p>Q = barges per tow</p> <p>R = turnaround time of a tugboat in hours</p> <p>S = transit time for tugboat</p> <p>T = number of tows a tugboat can deliver daily</p> <p>U = operational hours per day</p> <p>V = number of tugboats required to deliver tows</p> <p>W = tugboat maintenance factor (round up)</p> <p>Y = number of barges required for the IWWS</p>		

IWWS Capacity

After estimating the capacity of the three functional components of the IWWS, the least of the three capacities is used as the estimated capacity for the entire system (see Table 5-3). Once the capacity of the IWWS has been determined, personnel requirements for each component of the IWWS can be determined. If HN personnel are to support part of the IWWS, only the US Army personnel augmentation must be determined. If the capacity does not meet the requirements, adjustments can usually be implemented.

To determine equipment needed to support the IWWS, the planner must first determine the numbers and capabilities of barges and tugs that the HN will allocate to the US Army. This will allow determination of the US Army equipment augmentation requirement. Numbers of barges and tugs to support the IWWS can be computed by using the formulas given in this chapter.

During hours of darkness, an expanded use of radars is normally required. Searchlights and floodlights are also of great assistance. Operational radars should be on all vessels and at terminals and bridges as well as at locks. Expanded use of radars and lights should be carefully weighed during blackout conditions as these systems have a greater vulnerability to enemy detection and attack.

Ocean Reception Point

An ORP consists of mooring points for ships, a marshaling area for barges or other lighterage, and a control point. At least two stake barges should be at

each ORP, one for import cargo and one for export cargo. LASH, SEABEE, container, and general cargo vessels may discharge at an ORP. Because of the rapid discharge capability of LASH and SEABEE vessels, the ORP should have enough berthing to handle twice the barge capacity of these type of ships. Under the stake barge system, it should have water space with enough stake barges to accommodate the same amount of barges as the wharf space. Barges can be of the preloaded variety, such as those discharged from LASH and SEABEE vessels, or they can be barges or other lighterage loaded from container or general cargo vessels. In either instance, there must be enough wharfage or stake barge space to handle barges from the current working ships as well as returning empty barges from previous working vessels.

The reception capacity, discharge capacity, and clearance capacity of an ORP are computed the same as for a marine terminal with a few minor differences. ORP clearance capacity is the number of personnel, containers, barges, or STONs of cargo that can be moved from the ORP via any mode. Terminal transfer and storage capacity influences terminal discharge capacity. Tugs and barges (terminal transfer) and wharfs or stake barges (storage) also influence ORP discharge capacity. Careful analysis must be made to determine the space required and available for stake barges and space required to move barges to and from the stake barges. Transit time between the ship and the stake barge or wharf and other factors incidental to cargo, barge, and/or lighterage transfer and storage must also be determined.

Table 5-3. Daily IWWS capacity

ORP	INLAND WATERWAY	INLAND WATERWAY TERMINAL
3,000 tons	2,000 tons	2,500 tons

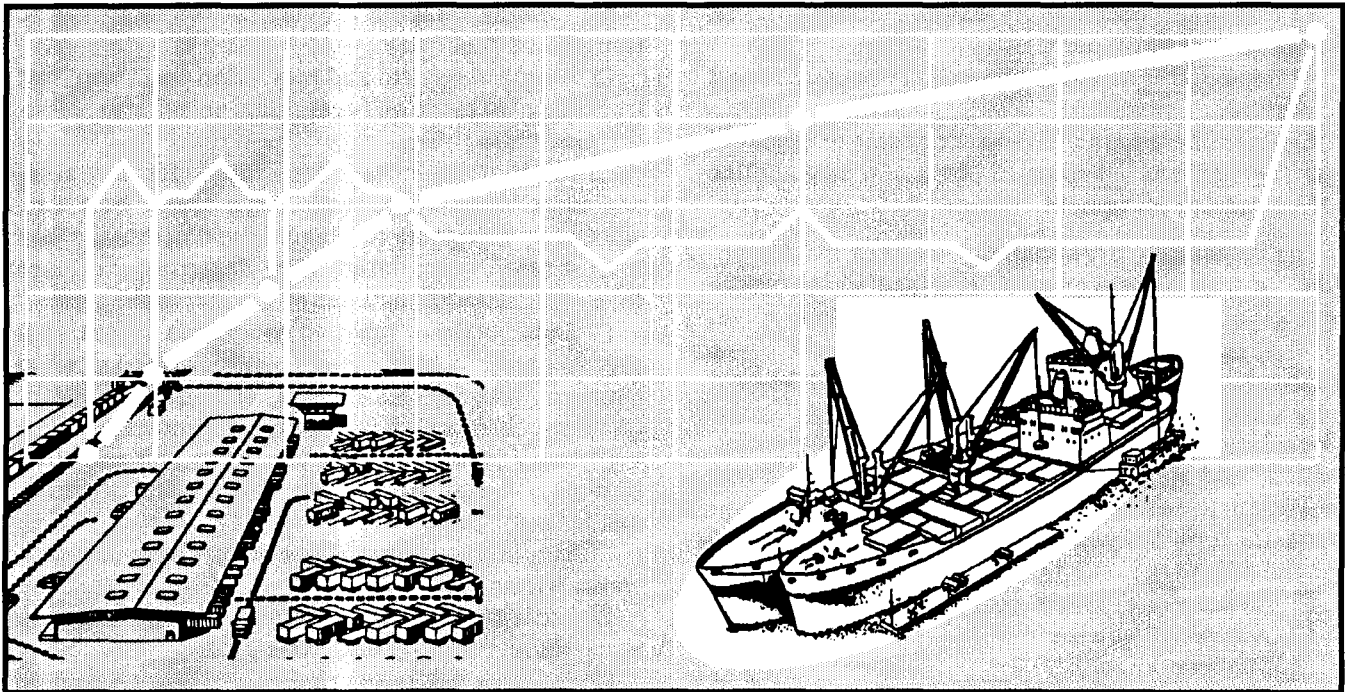

CHAPTER 6

MARSHALING YARD OPERATIONS

This chapter implements STANAG 2926.

INTRODUCTION

The loading and discharging of vessels are dedicated to rapid, efficient, and controlled movement of cargo between ship and shore. Improvements in cargo packaging, particularly containerization, add greatly to ship and cargo-handling productivity. The cargo marshaling yard is an essential part of this shoreside operation. It provides a place to hold and process cargo pending further movement. This chapter specifically addresses the container marshaling yard. However, much of the discussion applies as well to break-bulk cargo operations.

Use of a marshaling area allows rapid clearing of the beach or pier. It makes vessel working space available for its primary purpose. It reduces pier congestion, thus reducing the potential for work slowdowns or stoppages in discharge operations. Ideally, containers

and other cargo should go from ship's hook directly onto line-haul equipment for movement inland. In most cases this is not possible except for selected containers or other cargoes. Conceptually, all cargo should move through the terminal without delay. However, this is not always possible because of the following:

- The consignee's reception capacity may be limited.
- The movement plan causes delays in clearance.
- Damaged containers may require repair or restowing of contents before further movement.
- The consignee may move, causing some delay.
- Containers may require segregation by destination or priority.

- Containers occasionally require redocumentation before further movement.
- Some retrograde containers must be cleaned and fumigated.
- Containers found with broken seals or apparent pilferage must be inventoried and a new seal applied before onward movement.

The container (cargo) marshaling yard is a temporary, in-transit storage area. It expedites discharge operations by facilitating rapid and continuous movement of cargo and/or containers to or from the beach or pier. Marshaling cargo allows leveling of line-haul peak workloads that result from discharge operations. Concurrently, marshaling cargo allows selective, controlled, and flexible phasing of container or cargo movement to destination or vessel. In container operations, the terminal provides an area for the containers for the following:

- Maintenance, repair, servicing, and inspection.
- Unstowing/stowing.
- Documentation.
- Cleaning and decontamination.
- Marshaling for retrograde movement.
- Staging.
- Security.

STANAG 2926 (see Appendix C) ensures that national containerization procedures are internationally compatible and interoperable. This STANAG also includes factors relating to container selection, handling, inspection, and stuffing.

ORGANIZATION AND FUNCTIONS

A marshaling yard has no set organization or physical layout. It is organized to meet operational requirements within available space. By grouping related functions, the design of the marshaling yard will eliminate lost motion, reduce container and cargo-handling requirements, and permit a logical flow of containers and cargo through the terminal.

Cargo can be subdivided into any number of categories. The most widely used categories are general (break-bulk), containerized, RO/RO (vehicles and containers on chassis), and special (oversize, heavy lift, hazardous, and security) cargo. These categories and the volume of cargo in each category plays a significant role in marshaling yard organization.

All terminals should provide for the following activities and functions:

- A central control and inspection point with multiple lanes for cargo and containers entering or leaving the marshaling yard.

- Auxiliary internal checkpoints for containers and cargo entering the yard from a beach, from a rail spur, or by helicopter to a landing pad within the yard.

- A traffic circulation plan depicting movement flow into, through, and out of the marshaling area.

- Segregation of inbound containers and cargo by size and type. Within these groupings, further segregation by priority, destination, and special handling (security, mail, and hazardous) requirements.

- Segregation of retrograde cargo and containers by type and size with empty and loaded containers further segregated.

- Running inventory of containers by location and status within the yard.

- Security area for break-bulk or containerized sensitive and high-dollar-value cargo.

- External power source for refrigerated containers. (In an unimproved or bare beach LOTS environment, self-contained refrigeration units may be needed. This mandates separate propane or diesel refueling areas.) Refrigeration maintenance must also be provided.

- Sheltered facilities for inventory and control, documentation, and movement control elements.

- Covered facilities for stowing and unstowing containers and repairing cargo.

- Cleaning and/or decontamination of retrograde containers and vehicles.

- Minor repair of damaged containers.

- Equipment parking.

- Unit maintenance of equipment.

- Messing and comfort facilities.

- Spill contingency plans including emergency supplies and equipment for containing and disposing of hazardous material spills.

- Disposal of hazardous and special waste IAW federal, state, local, and HN environmental regulations.

A suggested general scheme for a container marshaling yard in an unimproved or bare beach LOTS environment is shown in Figure 6-1. The organization of and traffic flow through a fixed-port container transfer facility is shown in Figure 6-2 (page 6-4).

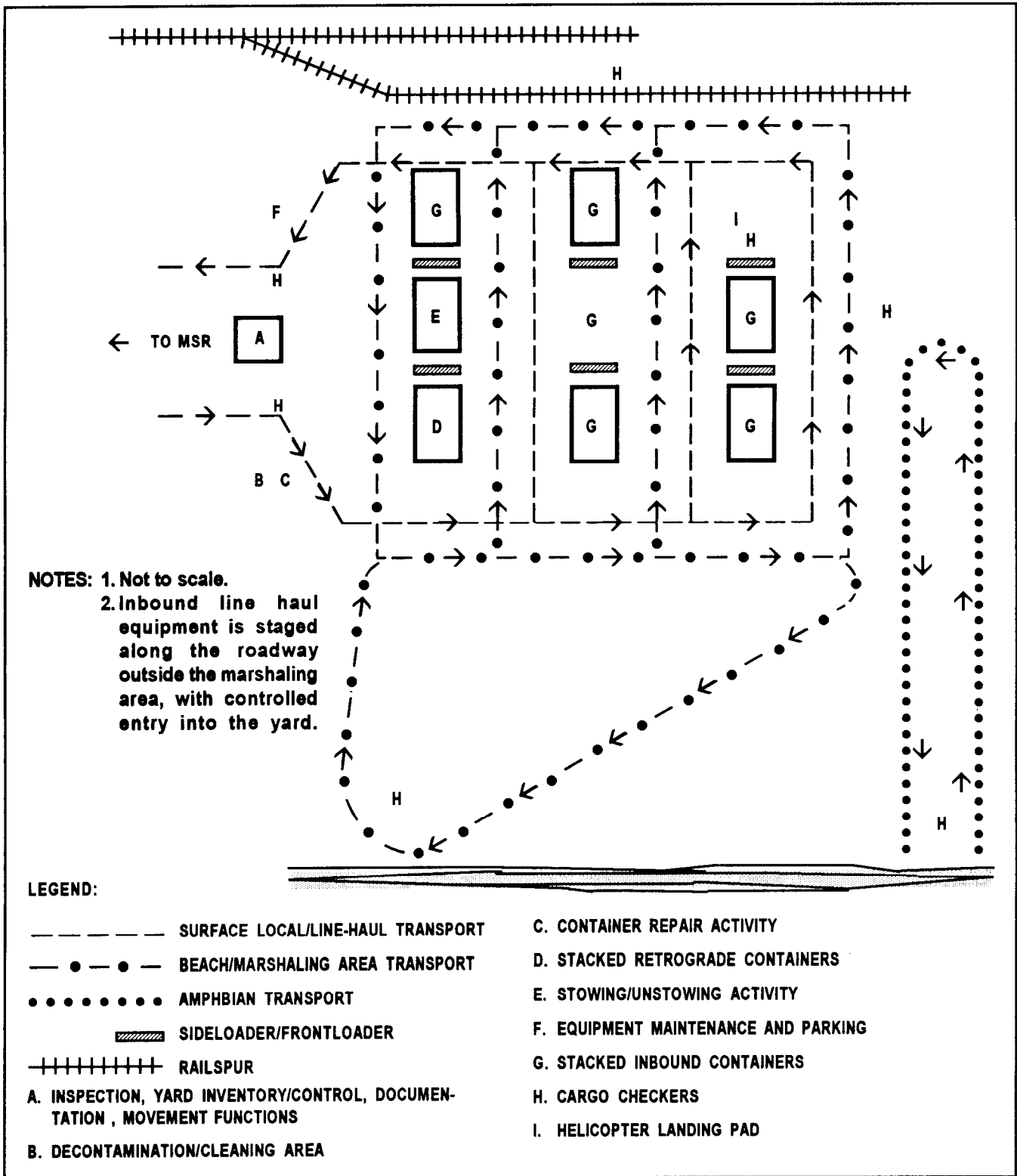

Figure 6-1. Suggested organization for a container marshaling yard in a LOTS environment

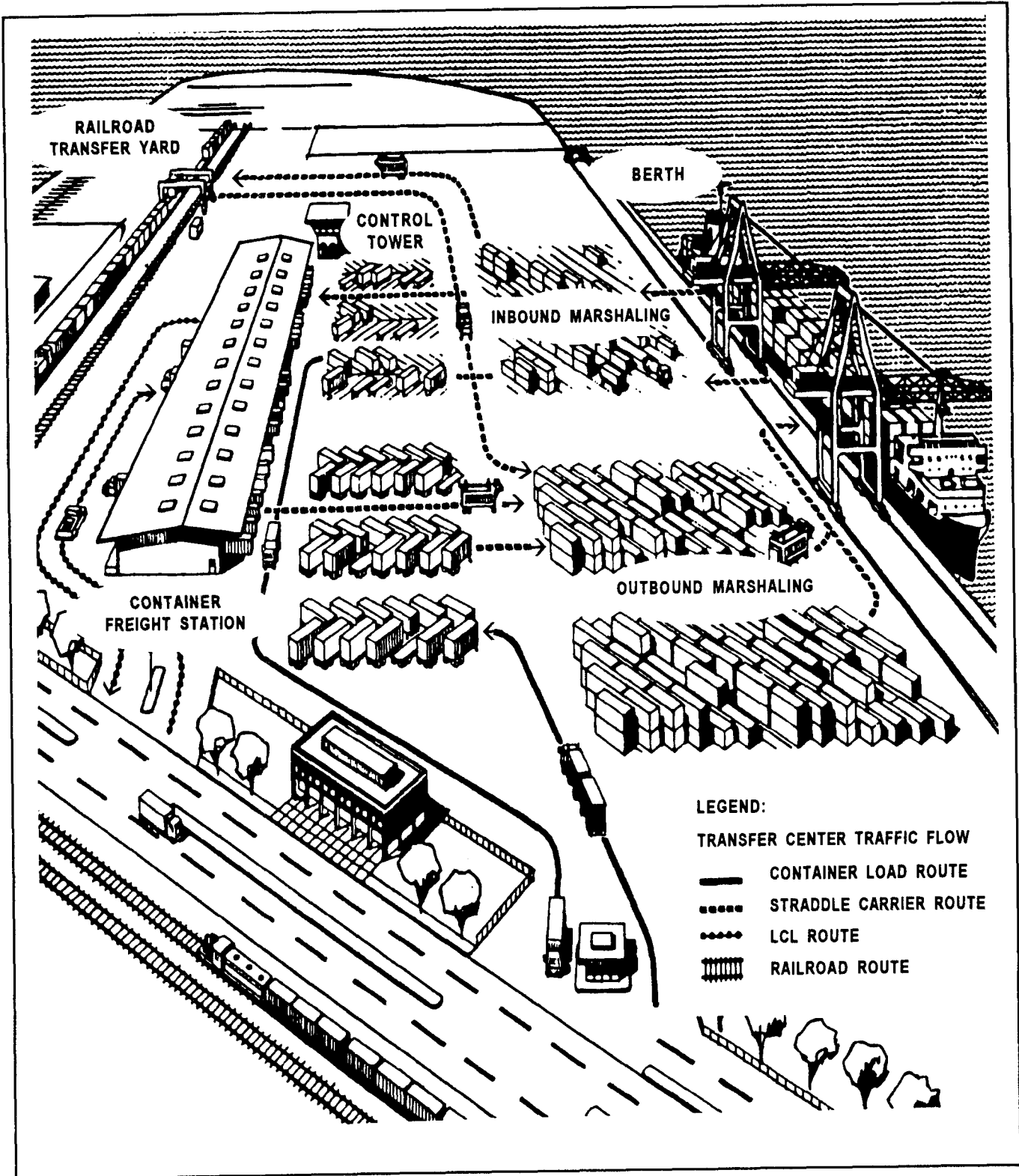

Figure 6-2. Example of organization of and traffic flow through a fixed-port container transfer facility

NOTE

The marshaling area in a TO provides essentially the same facilities. In addition to the space for temporary storage of containers, it needs space for any container repacking requirements, container repair, or other operational or administrative functions. Space requirements are influenced by the type, size, and number of containers handled; the length of time containers are held in the marshaling area; and available CHE.

SURFACE REQUIREMENTS

Surfacing of existing ports and those under construction is intended to support commercially operated equipment. The load-bearing capacities will meet foreseeable requirements.

Fixed and Semifixed Ports

Semifixed port surfacing has essentially the same load-bearing capacities as those of the fixed port. The type and quantities of cargo are essentially identical.

LOTS Operations (Unimproved Facility or Bare Beach)

In a LOTS environment, the marshaling yard surface may be subjected to loads of about 218,000 pounds (50,000-pound frontloader with a 40-foot container). Normally, beach movement of containers would be restricted to 20-foot containers or less. However, containers up to 40 feet may be used. An unimproved or bare beach facility does not normally have any surfaced area. Such surfacing must be provided comparable to that in a fixed or semifixed facility. A minimum surface would consist of 9 inches of rock or shell subgrade covered with an equal thickness of blacktop. Time constraints would prevent this type of construction in a LOTS environment. The materials below may prove useful to support limited loads in LOTS operations.

Matting, AM-2. This is a Navy-developed, extruded aluminum airfield mat. It is designed to support jet aircraft over soft, fine-grained soil. Because of limited stocks, high cost, and high priority for airfield use, this material will probably not be available for marshaling area use.

Matting, XM-19. This Army-developed, aluminum honeycomb-core, sandwich-type airfield landing mat is intended to support cargo and selected aircraft over soft soils. Limited stocks and priority for airfield use also restrict availability of this product.

Matting, M8A1. This is a corrugated steel airfield mat. It supports container-loaded trailers over sand, other granulated soils, and most relatively dry, fine-grained soils (clay and silt).

MO-MAT. This fiberglass-reinforced plastic is laid in sections that maybe bolted together or overlapped. It is less susceptible to water penetration and more easily placed than metal matting. It is effective over beach sand, granular soils, and some fine-grained soils (clay and silt). It relies on the support provided by underlying soils.

ON-FAST. This is fiberglass cloth, hand sprayed with polyester resin for reinforcement. Unless broken, it does not allow water penetration. It achieves support from underlying soils and is effective over beach sand, granular soils, and some fine-grained soils (clay and silt). Increasing the thickness and fiberglass reinforcement increases the matting strength.

LOCATION OF THE CONTAINER MARSHALING AREA

The marshaling area (general cargo or container, or both) is located as near the vessel, rail, air, or truck discharge or load site as practicable. Enemy capabilities and activities may require dispersion of activities or may otherwise effect the selection of the marshaling yard location.

Fixed and Semifixed Ports

The marshaling yard in an existing port is normally next to the pier area with a sufficient pier apron (100 to 500 feet) between the yard and shipside. These distances accommodate container discharge and container clearance activities and are more than adequate for general cargo operations. Rail spurs, warehouses, and similar facilities usually exist but may require rehabilitation. The semifixed port is constructed to replace an unimproved or bare beach LOTS site when a suitable fixed port is not available. Layout and construction of the semifixed port parallels that of the

fixed port. Construction of the marshaling yard should encompass any existing hardstand, structures, and rail lines.

LOTS Terminal (Unimproved Facility/Bare Beach Operations)

The LOTS marshaling yard should be approximately 1/4 to 1/2 mile (.4 to .8 kilometer) inland from the beach or dune area to allow an acceptable rate of beach clearance. The maximum distance should not exceed that needed for operations. LOTS operations are inherently inefficient. They should be used only until fixed facilities can be placed in operation or until semifixed facilities can be constructed. Port operational considerations and construction details dictate the length of time LOTS operations continue. Factors that influence marshaling yard site selection in a LOTS environment (unimproved facility/bare beach) consist of the following:

Accessibility. Is the area readily accessible from the MSR and from the beach? Are internal road nets adequate? If helicopter operations are anticipated, are there any flight obstructions? Is the proposed site next to existing rail facilities?

Physical facilities. Are usable physical facilities available? Are they served by more than one entrance and exit? Are usable hardstands, airfields, railways or rail spurs, buildings, storage sheds, or warehouses in the area?

Adequacy of space. Will available space hold the type, size, and quantity of cargo and containers programmed for the area? Is there adequate area for working and intersecting aisles? Will available space accommodate administrative activities; repair, maintenance, and decontamination operations; retrograde staging; and storage of handling equipment? Is there sufficient area to stage line-haul equipment pending entry into the marshaling yard for loading?

Gradient, drainage, and soil characteristics. Is the marshaling area sufficiently level, with minor grading, to permit general cargo stacking and two-high container stacking without toppling? Are surface and subsoil drainage adequate? What is the depth and type of subsoil? Is the surface soil compatible? Does the soil need compaction, stabilization, or surface matting?

Engineer support. Is engineer support required? Is support available? What type of support? Is the support cost justified? If engineer support is not available, can transportation units make the site usable?

STACKING CONFIGURATIONS

Containers may be placed in the marshaling yard either on chassis or stacked off chassis. Keeping containers on chassis reduces container handling and accelerates operations. However, when containers stay on chassis throughout the system, one chassis for every two to three containers is needed to support the system. Storing containers on chassis also increases space requirements in the marshaling area.

The Army operational concept is to stack load containers off chassis, with a maximum of two high, using the turret stacking method. Retrograde empty containers can be stacked five high if this height is within the capability of CHE. Other space considerations include stacking collapsed flat racks. Flat racks should be stacked as high as possible by available CHE in an area that facilitates retrograde for eventual back-loading. Although stacking containers increases handling, it requires fewer chassis and reduces requirements for marshaling yard space. The primary configurations of off chassis stacking are ribbon stacking, block stacking, and turret stacking.

Ribbon Stacking

Use this configuration (see Figure 6-3) when selective extraction of containers from the stack is not needed. This method requires more space than block stacking but is more space efficient than turret stacking. Use the ribbon stacking method if selective extraction is not required.

Block Stacking

Use this system (see Figure 6-4, page 6-8) when the containers have a common destination or when selective extraction of containers from the stack is not needed. This method is particularly suited to stacking (either empty or loaded) identical retrograde containers. It is the most effective use of marshaling yard space.

NOTE: Ribbon stacking may be used when all containers in the stack must be reached from the working aisle (the aisle between ribbons) but extraction of a particular container in the stack is not required. To illustrate, extraction of container A requires that container B first be removed and placed in the working aisle or carried completely out of the block. At best, this results in increased handling requirements and traffic congestion.

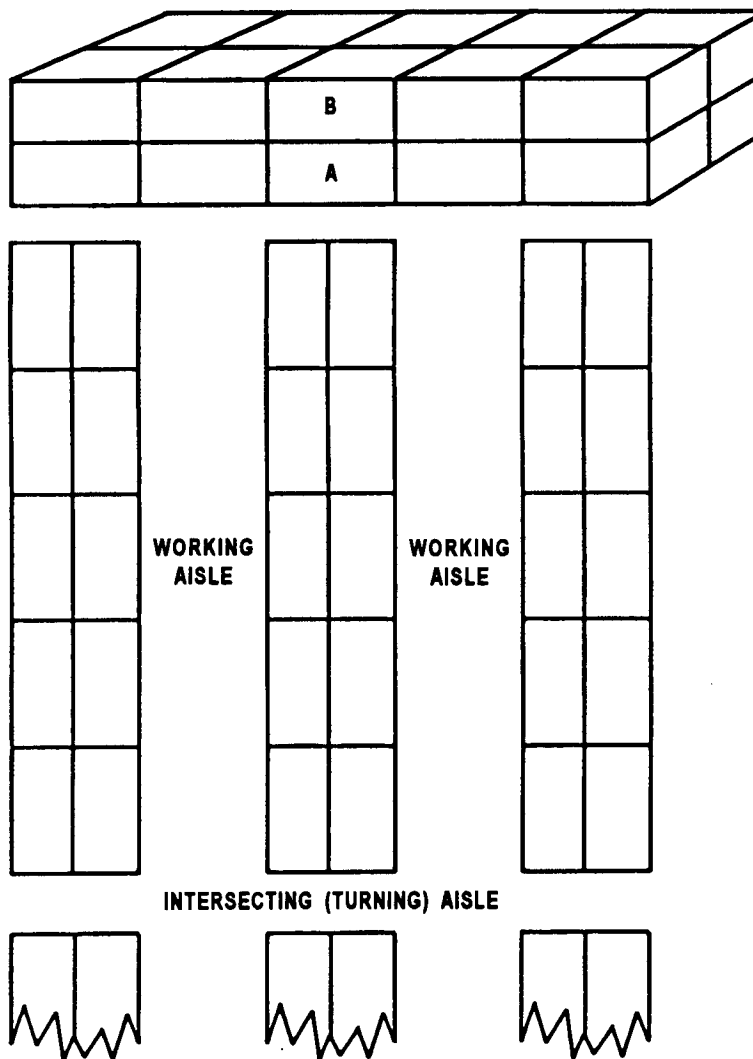

Figure 6-3. Ribbon stacking of containers

NOTE: Block stacking is ideal for identical retrograde containers, containers with a common destination, and in other cases where selective extraction is not required. Of the three stacking methods, block stacking uses space most economically.

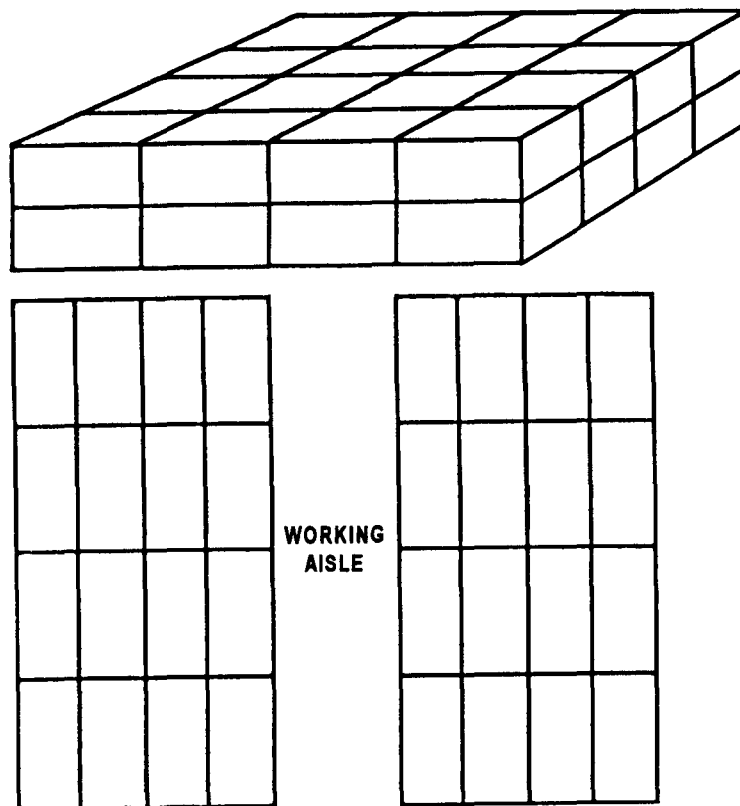

Figure 6-4. Block stacking of containers

Turret Stacking

This procedure (see Figures 6-5 and 6-6, page 6-10) requires less container-handling for selective container extraction than does ribbon or block stacking. Of the three off chassis configurations, turret stacking least effectively uses space. However, it greatly enhances the marshaling yard's throughput or retrograde operations where selective container-handling is necessary. Although three-high turret stacking is shown in Figure 6-6 the Army concept is to stack loaded containers only two high.

The container-on-chassis marshaling system (see Figure 6-7, page 6-11) is most often used in commercial

operations. Container-on-chassis marshaling is normally used in marine terminal operations where the container is lifted off the containership directly onto land transport or in RO/RO operations where the container-on-chassis rig is towed ashore from the RO/RO ship. Marshaling containers on chassis reduces container-handling and increases mobility and flexibility of operations. This method increases marshaling yard space requirements. It dictates a 2 to 1 or 3 to 1, or better, container-to-chassis ratio.

NOTE: Although the least economical in space, turret stacking is recommended when containers must be selectively extracted from the stack. As illustrated, one in three spaces in the second tier remains vacant. Any container in the stack can be removed with no more than two movements. For example, to get to container C, simply place container B over container A, thus exposing container C.

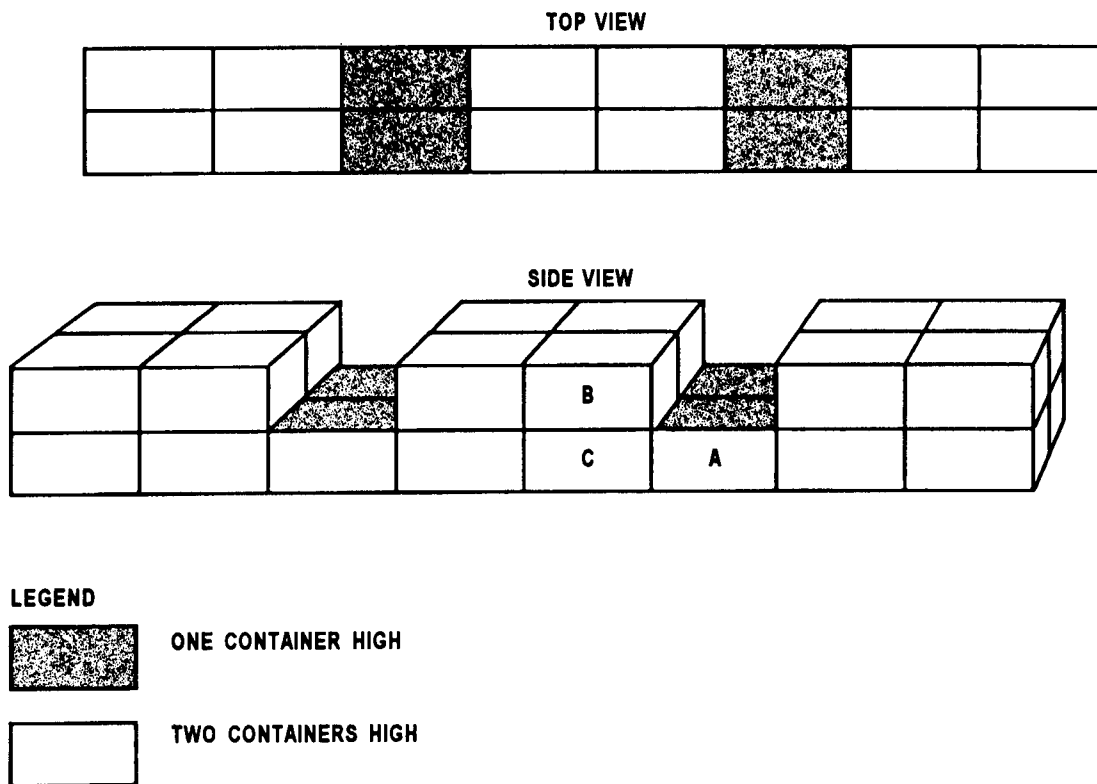
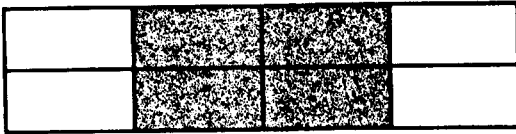

Figure 6-5. Turret stacking of containers (two-high)

NOTE: Here, two spaces out of four remain vacant in the third tier. Any container can be extracted in three or less movements. The method can be used in Army operations only when empty identical containers are being handled.

TOP VIEW



SIDE VIEW

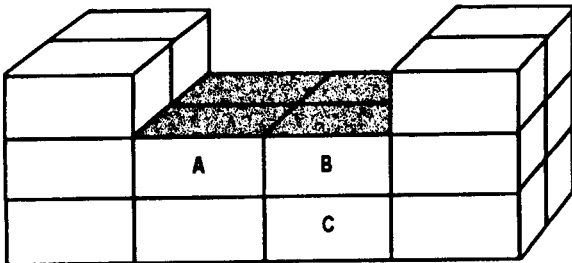

TO REMOVE CONTAINER C, PLACE CONTAINER B OVER CONTAINER A.

TOP VIEW

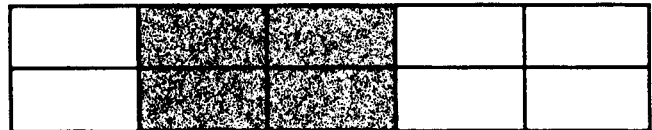

SIDE VIEW

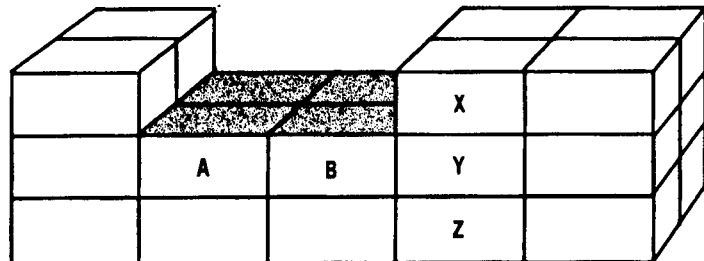

TO REMOVE CONTAINER Z, PLACE CONTAINER X OVER CONTAINER A, AND CONTAINER Y OVER CONTAINER B.

LEGEND



TWO CONTAINERS HIGH



THREE CONTAINERS HIGH

Figure 6-6. Turret stacking of containers (three-high)

NOTE: Shown here are two patterns of container-on-chassis (also referred to as container-on-wheels) marshaling: herringbone (pattern A) and straight-in (pattern B). A commercial operator can significantly reduce container damage in the marshaling area by changing from pattern A parking to pattern B. The same operator using pattern B can also, in the case of blacktop surfacing, install a narrow, hardened strip to support the legs of parked chassis. This keeps the legs from sinking into the blacktop.

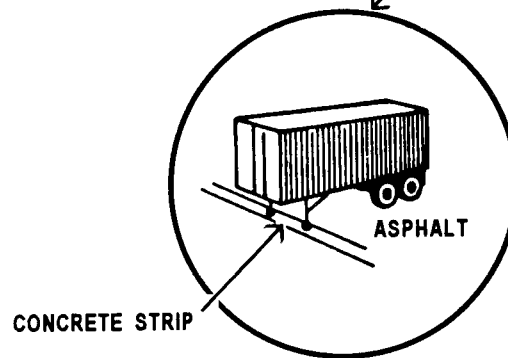
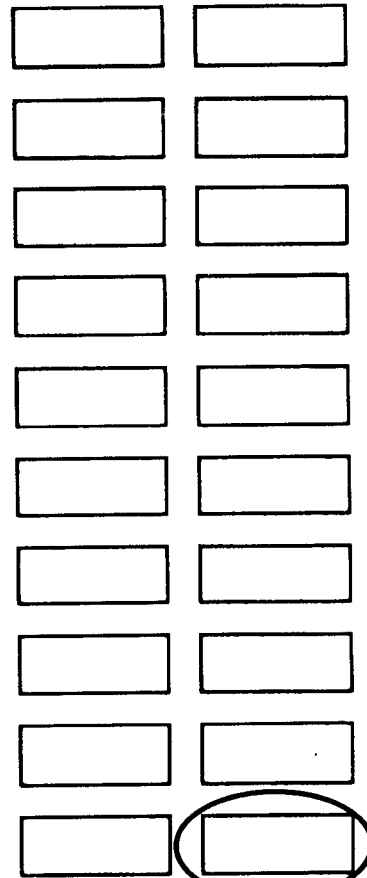
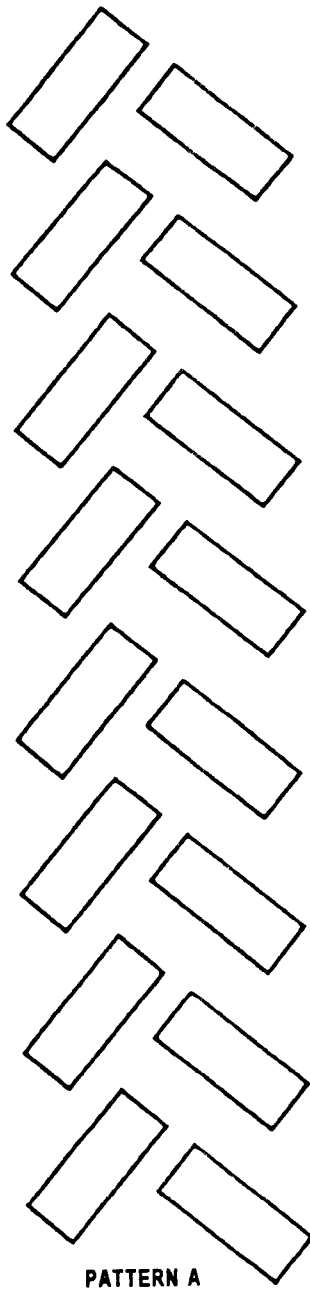

Figure 6-7. Container-on-chassis marshaling system

SPACE REQUIREMENTS

Numerous factors and combinations of factors dictate container stacking space requirements. Primary factors include the following:

Stacking Configuration

Ribbon stacking requires more space than block stacking; turret stacking, more than ribbon stacking. Concurrently, one-high stacking requires about twice the space of two-high stacking for the same number of containers. The relative space requirements of on chassis versus off chassis stacking are obvious.

Skill of Equipment Operators

Less skilled operators require more time to operate equipment. As operating skills increase, the need for more time decreases.

Physical Characteristics of CHE and Container Size

The recommended minimum operating space is a 15-foot working aisle with a 50-foot intersecting (turning) aisle when using sideloaders (see Figure 6-3). When using a frontloader, the overall length of the container being carried determines the effective width of the frontloader. For example, with a 20-foot container, the width of the vehicle is 20 feet. In a 90-degree stacking operation, a typical frontloader carrying a 20-foot container has a 45-foot turning radius. Aisle width must be adjusted to accommodate different container lengths.

Figures 6-8 (page 6-15) through 6-14 (page 6-21) present conceptual procedures for computing space requirements to stack containers in a marshaling yard. The concept envisions making clusters of containers grouped as needed to accommodate specific operational requirements or environments. Clusters are developed for turret stacking, block stacking, and on chassis parking for 20-, 35-, and 40-foot containers. Variations accommodate turret frontloader or sideloader stacking. The intersecting aisles are omitted in Figures 6-8 through 6-13.

Using the container cluster concept provides a relatively uncomplicated means of developing a marshaling yard commensurate with the needs of a specific operation or environment. This is done by grouping clusters within available real estate, modifying cluster

dimensions where necessary, and adding areas to provide the related activities. Figure 6-15 (page 6-22) shows a traffic pattern in on chassis marshaling area. Figure 6-16 (page 6-23) shows a hypothetical marshaling area developed within the cluster grouping concept. It is designed to support simultaneous discharge and/or back-load of one containership in a fixed marine terminal operation. Intersecting aisles of the required width are placed around each separate container cluster. When two clusters are adjacent, they use a common intersecting aisle of the required width (see Figure 6-16). Figure 6-17 (page 6-24) shows a pattern using one-way traffic where possible.

TERMINAL ACTIVITIES

The objective in any ship discharge operation is to minimize the turnaround time of the ship. One way to do this is to always have the terminal tractors available and positioned properly at the cranes working the ship. To do this efficiently, with minimum congestion, the tractors should travel the least distance possible. The stacking areas should correspond directly behind the crane's current working position at shipside. Hence, the two-deep stacking area can accommodate boxes from either crane as they work their way amidship. Each stacking area should be divided for import and export containers. Areas are divided to ease the drop-off of import containers and the pickup of export containers in one counterclockwise trip around the stacking area. One transportation company, terminal service, TOE 55-827L, works each containership. Operating on a 24-hour basis, the unit should handle (load and/or unload) 600 containers per 24-hour period.

Container Off-load and/or Back-load Operations

To off-load and/or back-load a containership, a minimum of two cranes will work each end of the ship in a coordinated effort. Each crane follows these steps in sequence for each hatch:

- Discharges all the containers on the hatch covers.
- Removes hatch covers.
- Discharges all containers from one cell.
- While discharging the next cell, back-loads the empty cell at the same time.

- ❑ Repeats all of the previous steps until all cells of that hatch are completed.
- ❑ Replaces hatch covers.
- ❑ Back-loads containers on hatch covers.

The operating terminal service company must maintain records of the stacking areas. These records give the specific location of each container within the terminal. Also, as each container comes off the ship, a predetermined storage slot must be known. The actual space (numbers of clusters) required per ship berth (terminal service company) depends mostly on the average dwell time of containers in the terminal. Potential bottlenecks in a marine terminal are as follows:

- ❑ The dwell time of containers.
- ❑ Frustrated containers.
- ❑ Processing of containers at entrances and/or exits.
- ❑ Stuffing and/or unstuffing of containers.
- ❑ Cleaning and/or maintenance of containers.
- ❑ Method for container accountability.
- ❑ Vehicle delay and congestion.

Marshaling Area Clearance Operations

This operation ensures containers flow rapidly and uniformly between dockside and the hinterland. To minimize terminal congestion and work stoppages, marshaling area clearance operations are tailored to port unload and/or back-load output. An inbound container should not remain in the marshaling area longer than 24 hours. This also holds true for retrograde containers, provided a containership is available for back-loading. The normal procedure in clearance operations is to designate specific medium truck units to support a specific container unload and/or back-load operation.

The following paragraphs discuss motor transport requirements for marshaling area clearance support of one terminal service company operation. In all cases, medium truck units operate around the clock (two shifts) with 75 percent equipment availability. The terminal service company unloads and, at the same time, back-loads 300 containers per day (two 10-hour shifts). Ideally, inbound containers should be cleared within 24 hours. If this is the case, a minimum of 300 containers per day must be cleared from the marshaling area. (For planning purposes, it is assumed that for

each container moved from the marshaling area a retrograde container is returned.) Refer to FM 55-20 for clearance of the terminal by rail and FM 55-30 for clearance of the terminal by highway.

The traffic patterns within the terminal must be designed to support the cranes servicing a ship (see Figure 6-17). Traffic patterns should be counterclockwise: up one side of the cluster when dropping off a container and down the other side when picking up a container.

Related Support

A HHC, transportation terminal battalion (TOE 55-816L) provides the basic operating HQ for theater terminal operations. It is the normal command element for each two- to four-ship marine terminal.

If it is a two-ship operation, a terminal battalion would operate the terminal. The battalion operations officer supervises consolidated battalion operations for documentation, inventory, and control functions. The battalion also controls operations of areas such as stowing and/or unstowing, inspection, maintenance and repair activities, cleaning and decontamination, equipment parking, and security at battalion level. Thus the terminal service companies can devote their efforts to container handling. Figure 6-18 (page 6-25) is a suggested design for security storage in a container marshaling yard.

MARSHALING FOR RAIL MOVEMENT

Container movement by rail is used wherever possible. Rail presents a mass movement capability with little interference from weather or refugee traffic. Except for inland waterway, rail is the most economical mode for moving Army containers. Figure 6-19 (page 6-26) presents a procedure for marshaling, loading, and/or unloading containers for a rail movement when the rail facilities are not a part of or adjacent to the marshaling yard.

PROCEDURES

The commander of an overseas port is responsible, through the operations officer, for operating the port's container marshaling yard. The operation may be

keyed to automated documentation procedures or, if automated data processing equipment is not available, to manual procedures.

Import Cargo

For import cargo, the shipping port transceiver advance manifest to the receiving port (TO). Upon receipt of the advance manifest, the receiving port sets up files for preparing documentation. These files include hatch summaries, PCCPs, CDIs, and TCMDs. Hatch summaries, preprinted from the advance manifest, provide the operator with advance notice of the types (cargo or refrigerated) by size and quantity of incoming containers, movement priorities, and ultimate destinations. This information (in conjunction with the PCCPs) permits the operations officer to preplan marshaling yard space requirements and to predetermine where each off-loaded container will be stacked. This is particularly important in the planning of onward movement of outsize and/or overweight cargo. Figure 6-20 (page 6-27) shows a system for identifying containers by number and location within the marshaling yard.

NOTE

In Figures 6-6 through 6-17 the container clusters are lettered. Within each cluster, the rows are lettered. The marshaling yard and the cluster and row designators are combined to form a three-character alpha designator acceptable to the data processing system. Thus, container X acquires the designator of A-B-C: it is in row C, of cluster B, of marshaling yard A. This designator may be card-punched and entered in the tape of the CPU. Marrying up each container number with its location designator in the computer memory provides a computerized container yard inventory. When a container moves out of the yard or is relocated within the yard, the change is entered in the CPU by punch card. Thus, the inventory remains current. The computerized inventory should be verified daily by a physical inventory. If desired, a locally fabricated visual display board may back up the computerized inventory.

Stacking Location

Since the stack location of the container is planned, the cargo checker can receive a printout for the containers he will be tallying. Using this as containers are unloaded from the ship, he can direct the yard transporter to the designated stacking area. Radio communication between the cargo checker and the marshaling yard is the only way to ensure adequate control of the operation, especially in a large yard or in a highly flooded situation. If computer equipment is not available, a visual display board of the stacking area is kept by operations to provide container identification and location. A manual system requires appropriate internal communications.

Cargo Disposition Instructions

These are used as a consignee advance notification document. Based on the CDI, the port's servicing MCT coordinates with the consignee's MCT to ensure that the consignee can receive the shipment. They arrange delivery dates and transportation to move containers from the marshaling area to final destination.

Retrograde Movement

When a retrograde container enters the marshaling yard, the container transporter driver presents the TCMD at the entry point and has the container inspected. He gets a receipted copy of the TCMD (proof of the delivery) and is directed to the point where the container is to be unloaded. (He also gets a TCMD for the container that he will pick up for movement out of the yard.) A TCMD is required each time cargo is moved from the AOR. No container can be moved out of the marshaling yard exit or entry point without proper documentation and inspection. The container, the container transporter, and the container seal numbers must all agree with those shown on the TCMD. If not, the container will not be moved until proper documentation is prepared. When the container departs the marshaling yard, a copy of the TCMD is retained for entry into the CPU. It must be retained to show that the container has been shipped to the consignee and to update the computerized marshaling yard inventory.

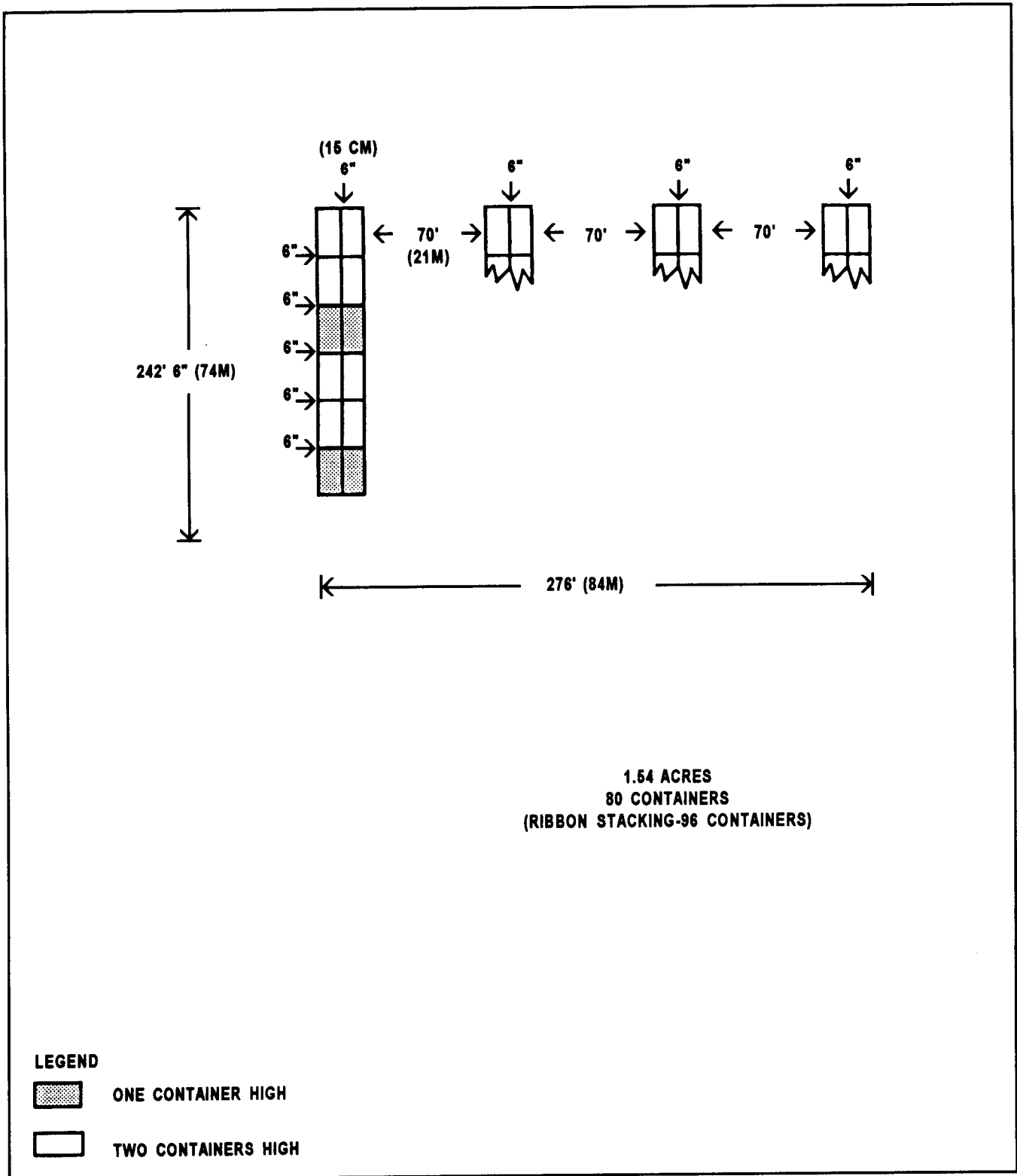

Figure 6-10. Cluster plan for frontloader turret stacking of 40-foot containers (70-foot working aisles)

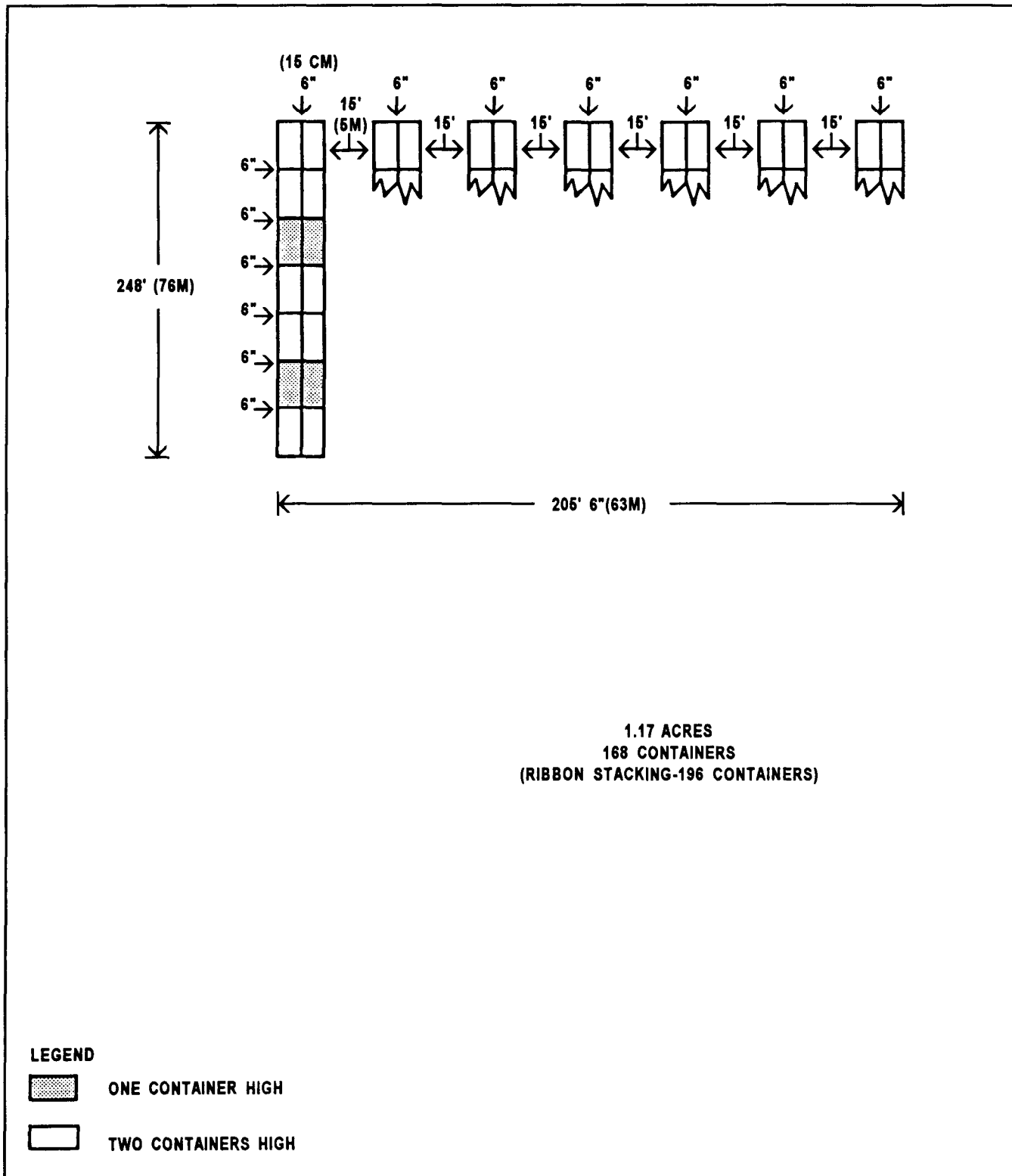

Figure 6-12. Cluster plan for sideloader turret stacking of 35-foot containers (15-foot working aisles)

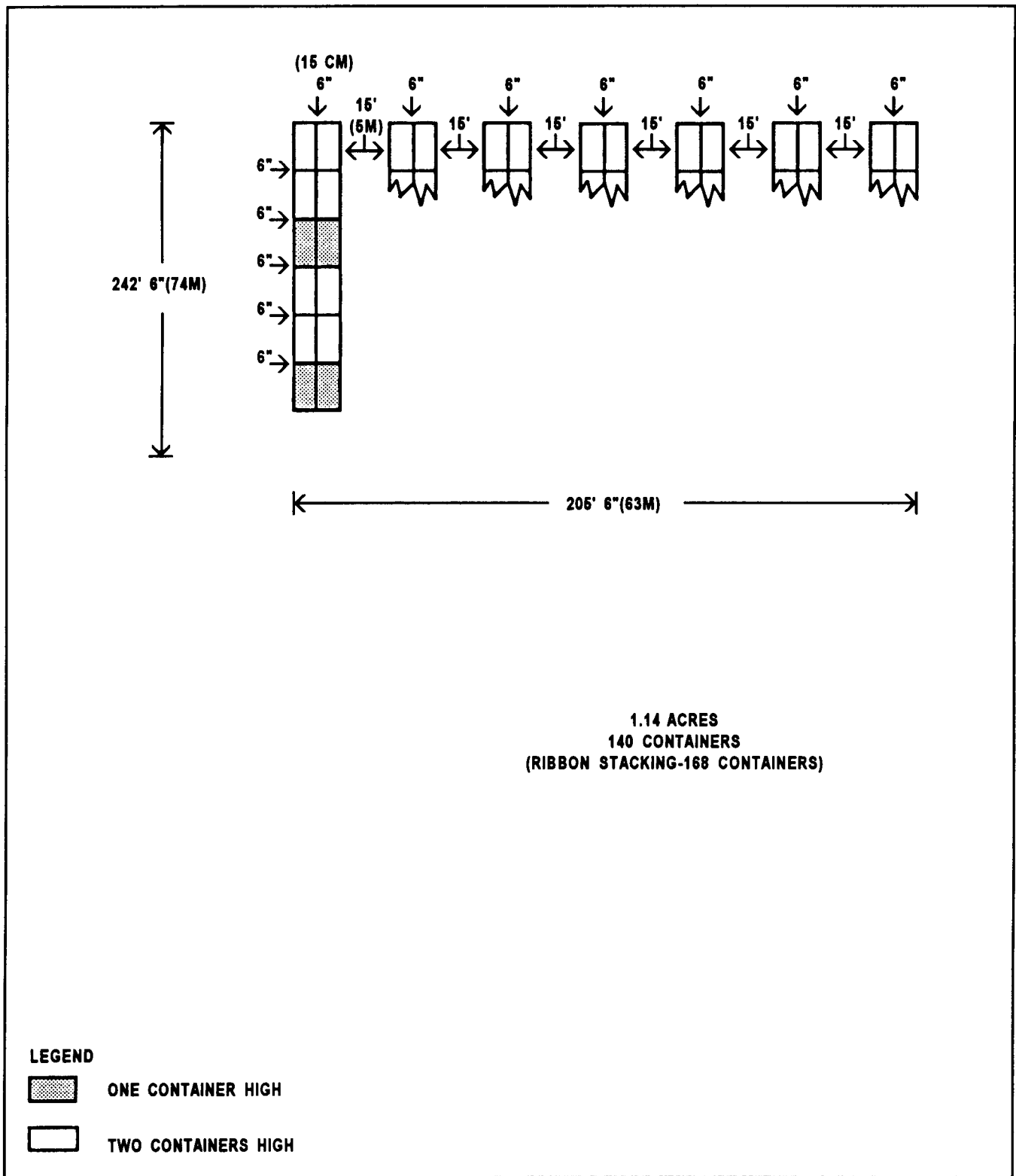

Figure 6-13. Cluster plan for sideloader turret stacking of 40-foot containers (15-foot working aisles)

NOTE: Each cluster differs, depending on the size of the container stacked, the type of CHE used, the size of the area, and the number of containers required. The intersecting aisles differ in width depending on the equipment used. There is an intersecting aisle around every cluster. Two adjacent clusters share a common intersecting aisle. Working aisles not generally required would be the same as in turret stacking if used. The widths of intersecting aisles (in feet) for different equipment and containers are as follows:

EQUIPMENT	20-FOOT	35-FOOT	40-FOOT
FRONTLOADER	50	60	70
SIDELoader	50	50	50
STRADDLE CARRIER	50	50	50
ON CHASSIS	40	45	50

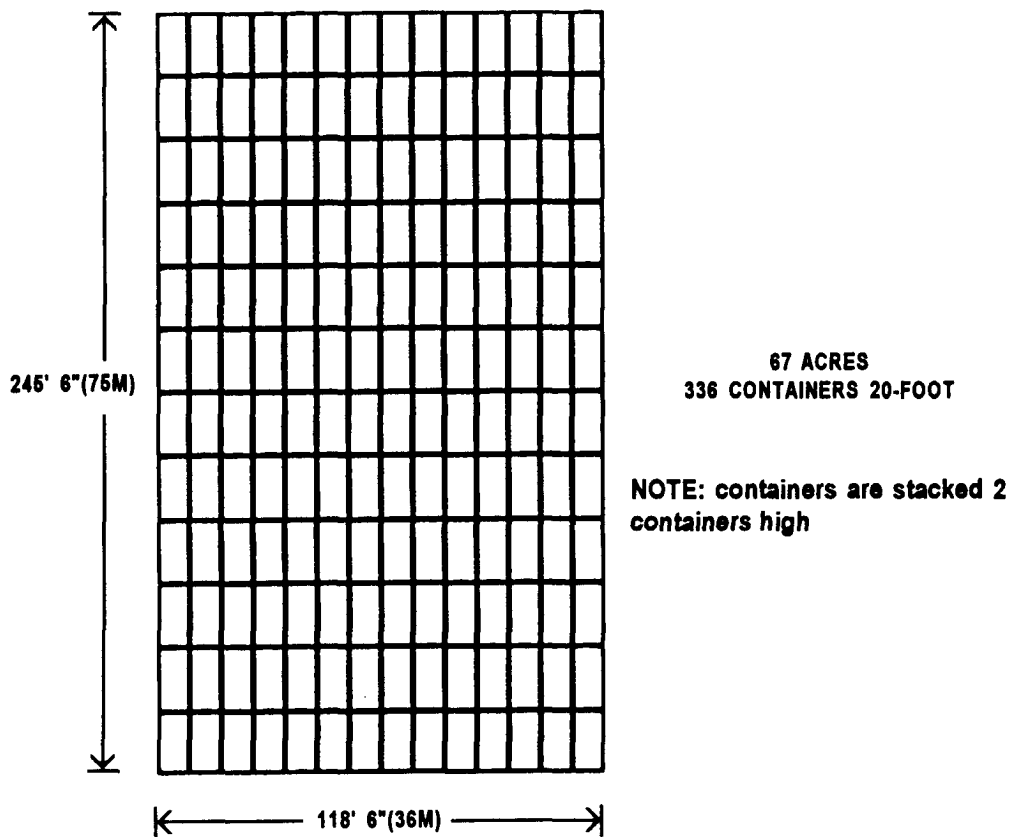

Figure 6-14. 20-foot container cluster

NOTE: The 90-degree on chassis pattern is the system recommended for US Army terminals. This figure is designed for a 20-foot chassis. When planning for on chassis marshaling areas, sufficient working areas must be allowed to move the chassis in and out of the aisle. Although shown in the figure on each side of the cluster, the aisle is a combination of working and intersecting aisles. There must also be enough distance between each chassis so they can be maneuvered and people can work between them. There should be a few inches allowed between the backs of each chassis to reduce damage to chassis and containers. Below are distances of aisles (in feet) by size of container.

AISLE	20-FOOT	35-FOOT	40-FOOT
INTERSECTING	30	30	30
WORKING	40	55	60
COMBINATION	40	55	60
BETWEEN CONTAINERS	2.5	3.0	3.5

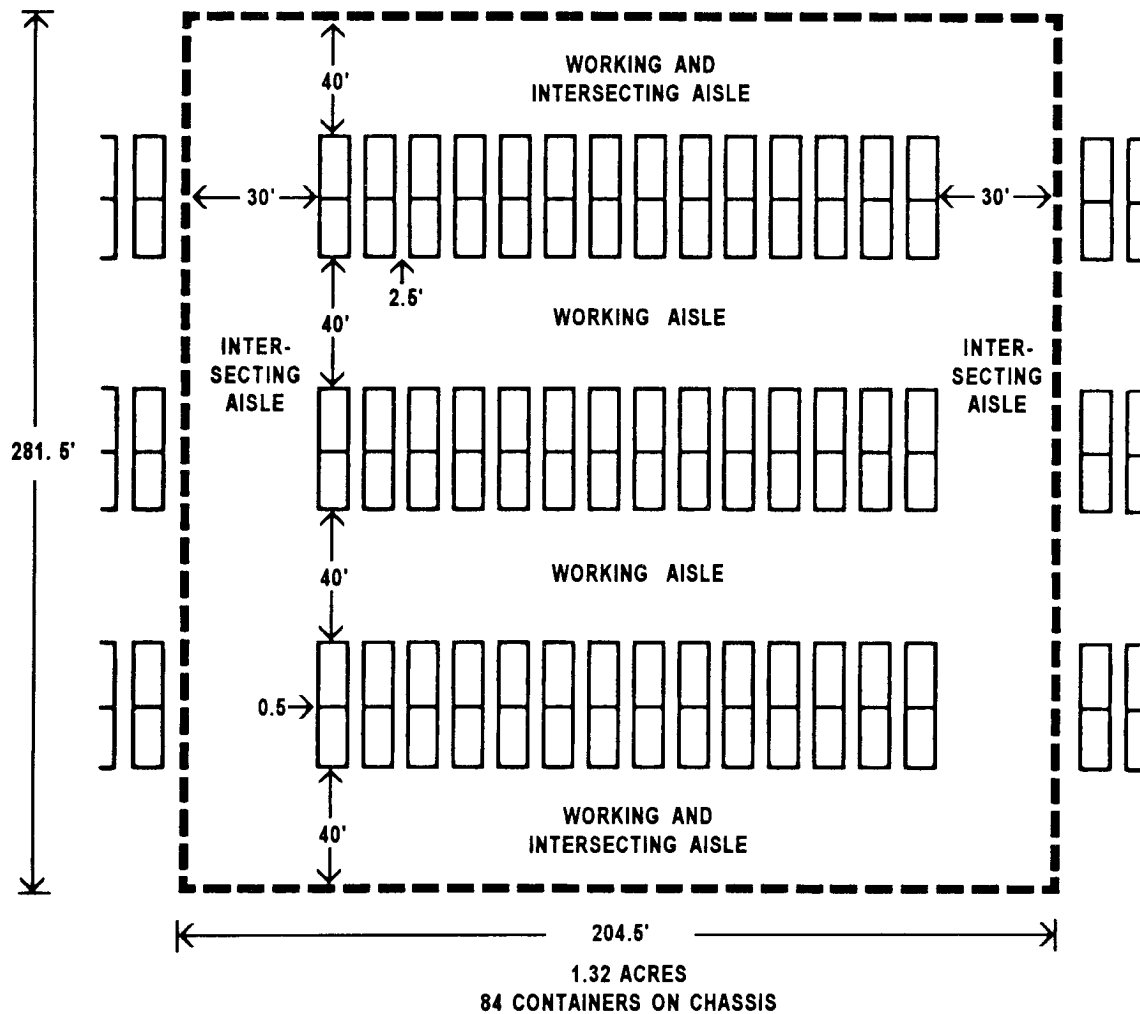
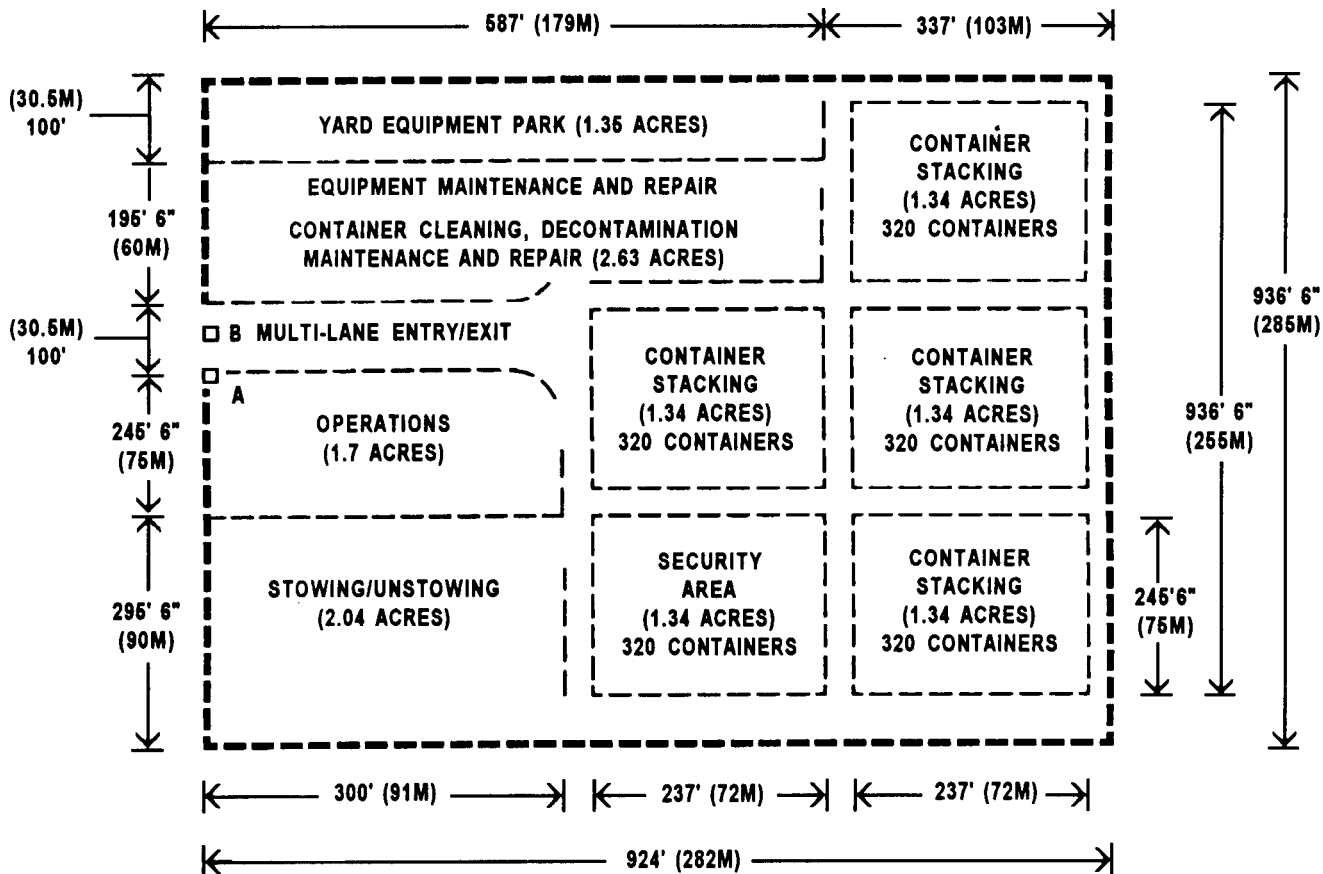

Figure 6-15. Traffic pattern in on chassis marshaling area

- NOTES:** 1. This hypothetical terminal shows relationships between the administration services areas and the container marshaling areas. The area provides for sideloader turret stacking of 20-foot containers, using 15-foot working aisles. The cluster plan is shown in Figure 6-11. These clusters (except security) are each divided for import and export containers. A further division is needed if a mix of 20- and 40-foot containers are used.
2. area dimensions not to scale



LEGEND:

- A- CONTROL POINT FOR PEDESTRIAN TRAFFIC. PERSONNEL ON FOOT ENTER AT GATE A AND ARE ISSUED COLOR CODED, NUMBERED BADGES THAT INDICATE SPECIFIC AREAS OF AUTHORIZATION(AREA "M" FOR MAINTENANCE, AREA "O" FOR OPERATIONS, ETC.)
- B- CONTAINER CONTROL/INSPECTION POINT (ONLY CONTAINER TRANSPORTER/MHE TRAFFIC IS PERMITTED BEYOND THIS POINT). THE TRANSPORTER DRIVER PULLS INTO PARKING AREA ADJACENT TO OPERATIONS, CHECKS IN HIS TCMD AND DRAWS AN OUTBOUND TCMD. HE THEN DEPOSITS HIS CONTAINER IN A SPECIFIED LOCATION, PICKS UP AN OUTBOUND CONTAINER, AND DEPARTS. THE MULTI-LANE ENTRY/EXIT SHOULD PROVIDE UP TO SIX LANES WHICH MAY BE DESIGNED AS EITHER AN ENTRY OR EXIT, AS TRAFFIC REQUIRES.

Figure 6-16. Hypothetical marshaling area

- NOTES:** 1. Traffic patterns are designed to offer one-way traffic where possible, to minimize distance to travel and to eliminate congestion.
2. Area dimensions not to scale

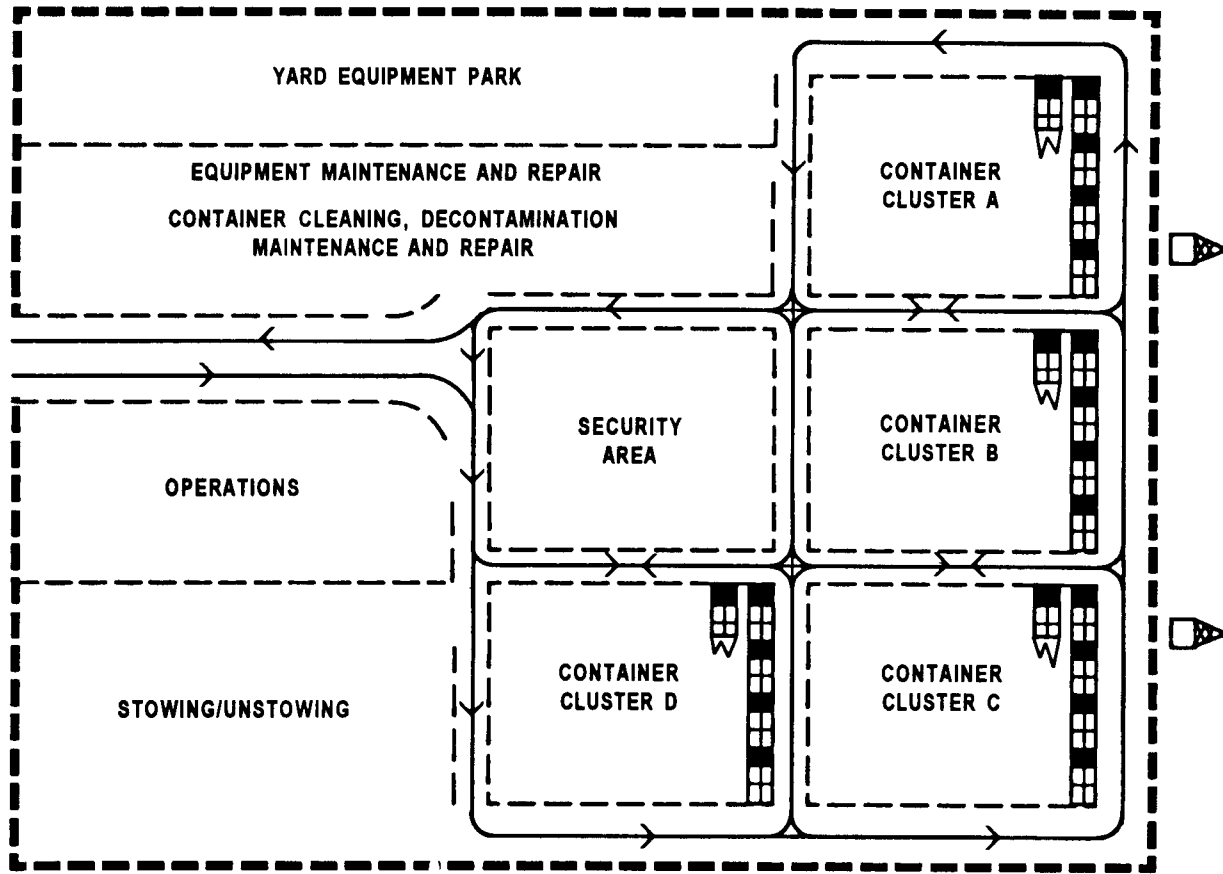

Figure 6-17. Suggested traffic flow in fixed terminal marshaling area

NOTE: Ideally, the entire terminal is enclosed. As a minimum, however, the security area should be enclosed, preferably with a cyclone-type fence topped with several strands of barbed wire. Concertina wire may be used as an expedient. If circumstances permit, a double fence should be installed. A 24-hour military guard should be placed on the gate. The perimeter should be patrolled periodically. Door-to-door placement of containers further strengthens security measures. Sensors, protective lighting, high security locks, and access control procedures should be considered to help secure high-priority cargo. Adequate lighting and a sophisticated and constantly changing pass system greatly enhances security operations.

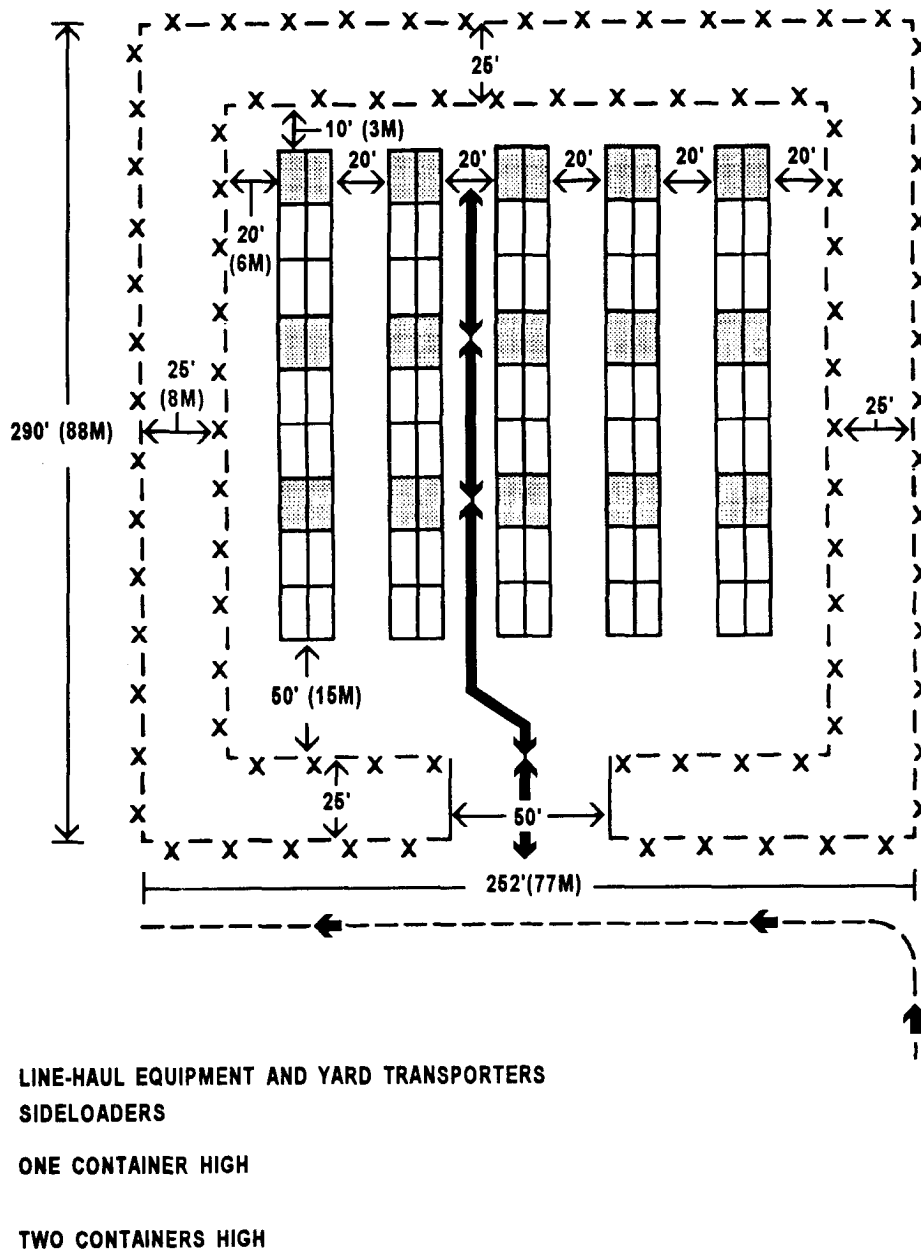

Figure 6-18. Suggested design for a security storage area

NOTE: Here, retrograde containers are being exchanged for loaded containers, which will be moved inland. Before flatcars arrive, truck-transporters move loaded containers to trackside, where they are prestacked two-high as shown. After the flatcars are positioned, loading and/or unloading proceeds as follows: Container 1 moves to position B-1. Container A-1 is loaded in position 1. Container 2 moves to position B-2. Container A-2 is loaded in position. The process is repeated for the next flatcar. As the procedure continues, road C is used to remove retrograde containers to the marshaling area. This system is only used in certain circumstances. When other equipment or circumstances prevail, other systems are used.

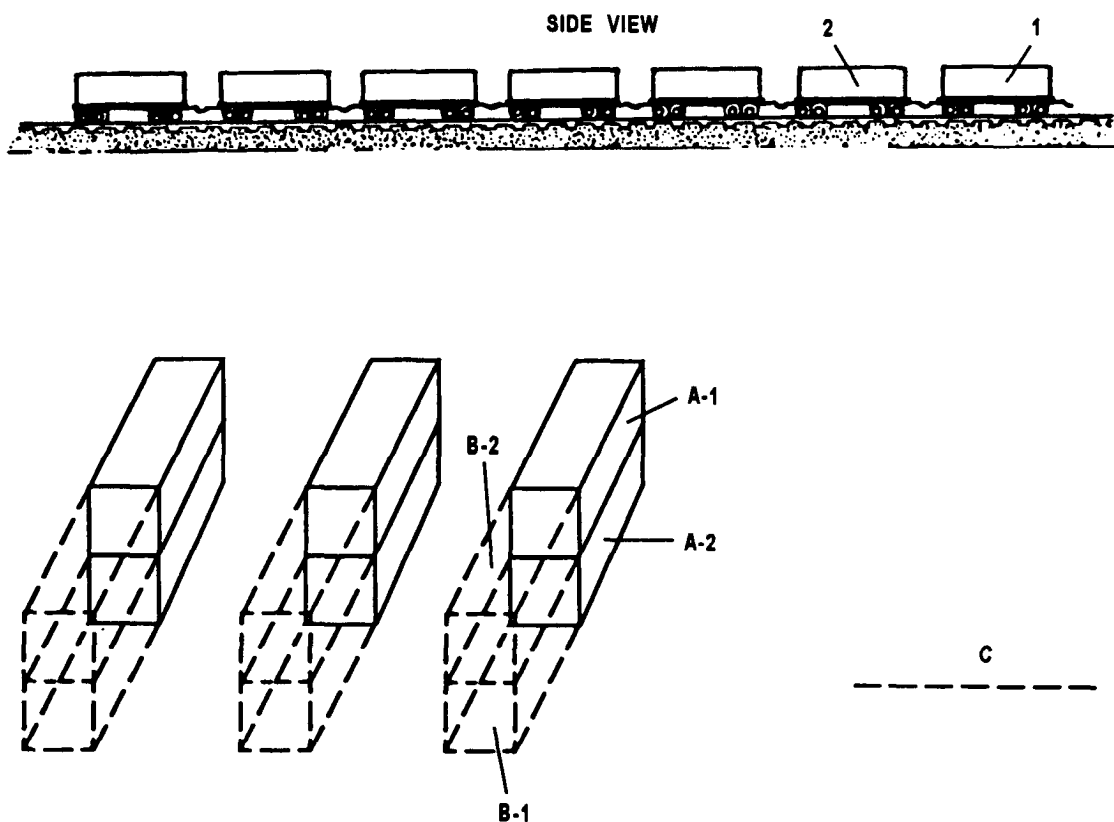

Figure 6-19. Procedure for marshaling/loading/unloading containers for rail movement when rail facilities are not a part of, or adjacent to, the marshaling yard

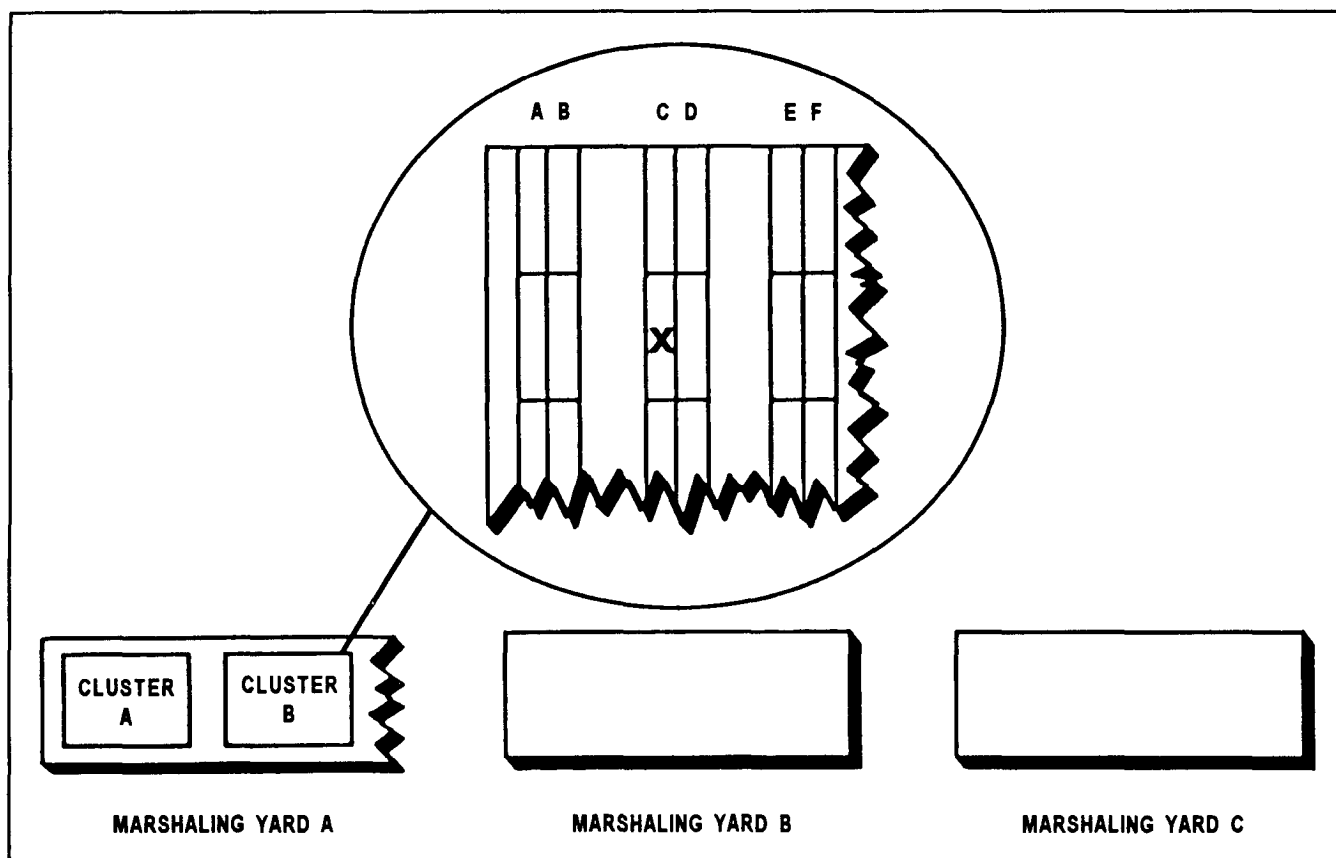

Figure 6-20. Automated system for container identification by row location within the marshaling yard

SECURITY

Losses under containerization are growing. They have become of major concern to industry and government alike.

Cargo Theft and Pilferage

Reduction of cargo theft and pilferage is a significant benefit of containerization. Compared to losses suffered in break-bulk operations, the reduction is indeed noteworthy.

Inbound/Outbound Traffic Control

Strict control of incoming and outgoing traffic is a key factor in marshaling yard security. Restricting vehicular traffic entering or exiting the container stacking area to container transport equipment, MHE,

and mobile scanning equipment is essential. Also essential is the establishment of a single control point (gate) for vehicular traffic entering or exiting the container stacking area. US military personnel assisted, as necessary, by foreign national police and/or interpreters, man and operate this point. Military personnel assisted, as necessary, by foreign national police and/or interpreters should operate a separate gate for pedestrian traffic. Surveillance and control functions of the vehicular control point include the following:

- Preventing entry of unauthorized vehicles.
 - Inspecting inbound and outbound containers.
- This is a thorough physical inspection including container condition; presence and condition of container seal and/or lock; evidence of illegal entry (such as

tampering with or removal of door hinges); and, particularly for outbound containers, stolen items (look on top of and under the container and inspect the transporter cab).

- Verifying documentation for correctness, completeness, and legibility. (Ensure that transporter, container, and container seal numbers match those shown on the TCMD.)

- Operating scanning equipment. (If there is no scanning capability, container numbers are reported manually to operations so that the yard inventory may be updated.)

- For outbound containers, entering the departure time and date on the TCMD and retaining copy for terminal files.

- For inbound containers, signing one copy of the TCMD for the transporter operator to keep as a delivery receipt.

Surveillance and control functions of the pedestrian control point include the following:

- Permitting only authorized personnel to enter the container marshaling area (mainly concerns foreign national contract operators and other indigenous personnel).

- Maintaining, controlling, and safeguarding the pass system for foreign national personnel authorized to be in the area.

Perimeter

Security of the marshaling yard perimeter backs up gate security in keeping unauthorized persons out. Such persons may engage in sabotage, petty theft, and large-scale theft operations and may establish inside contacts with foreign nationals or other persons working in the yard. While it may not be possible to fence the entire yard perimeter, the security (sensitive, classified, or high-dollar-value cargo) area should be fenced with its own military-guarded gate and MP control. Perimeter defense measures may include one or a combination of the following:

- Chain-type fencing topped by three strands of barbed wire. (Inspect fence daily to ensure there are no holes or breaks.)

- Concertina wire.

- Use of a sensor, when feasible.

- In LOTS, mined strips on the land side.

- Use of patrols.

Container Transporter Operator

Drivers of the line-haul and local-haul container transporters are required to remain in the cab of their truck when operating within the container stacking area.

Cargo

As already stated, security cargo should be stored separately from other cargo and should have its own secured area. Whenever possible, security cargo should also be unloaded from the ship during daylight hours. If possible, MP security personnel should observe unloading operations.

TCMD

No containers are allowed to move through the marshaling yard entry or exit (control) point without a valid and legible TCMD.

When the MCT determines that a container is to be forwarded to the consignee, it informs the documentation section and the control point. The MCT gives the date of the movement, the container number, and the name of the consignee to the documentation section. The documentation section then prepares the TCMD and informs the MCT and the control points of the actions, giving the container number, the TCN, and the transporter number. These coordinating procedures prevent removal (either accidentally or purposely) of containerized cargo from the yard. At the gate, the container number is verified against the information provided by the movement and the documentation sections. The container, seal, and transporter numbers are verified for agreement with those entered on the TCMD. The container's seal is examined for breakage or evidence of tampering. Finally, before the container is released, it is inspected for damage. When the control people release the container, they notify the MCT. It in turn notifies the consignee MCT that shipment has been made.

A TCMD must also accompany retrograde containers. After control people verify TCMD entries (such as container and seal numbers) and inspect the container, they give the driver a receipted copy of the TCMD. They also give directions to where the container is to be unloaded.

Verification of Cargo Arrival

Upon receipt of the container, the consignee returns a copy of the TCMD to the shipping terminal activity.

The TCMD contains the consignee signature, date of receipt, and condition of cargo, container, and seal.

Container Seals

Normally TCMDs are not accountable documents. However, local procedure may serially number TCMDs. This is an excellent procedure to deter their use in organized thievery. Regardless, blank TCMDs should be secured. One individual should be responsible for safeguarding and issuing them.

A container seal is a device applied to the container door fastening. It indicates whether the door has been opened or the fastening tampered with, and if so, at what point in the movement system it happened. Seals are serially numbered to help identify the person who applied the seal and to provide a means of control. Failing to strictly account for seals from receipt to application defeats their purpose (to pinpoint unauthorized entry into containers). Container seal control and accountability are promoted by the following procedures:

- Maintain a record, by serial number, of seals received by the port operations officer and issued to authorized personnel for applying to containers.

- Store seals under lock. Designate one person to be responsible for the safekeeping, issuing, and recordkeeping of seals applied at the port.

- Designate specific persons (keep the number to a minimum) on each shift to apply seals and enter the serial number of the seal on the TCMD.

- Conduct periodic inventory of seals.

- Apply seals as soon as the container has been stuffed and as soon as a loaded (unsealed or improperly sealed) container is detected.

- Supervise the seal application. Failure to supervise or allow a yard hustler to move an unsealed container to the stacking area offers an opportunity for pilferage of cargo before seals are applied. It also affords the opportunity to apply a bogus seal, to break the seal later, and to remove cargo and then apply a legitimate seal.

Computing Container Space Requirements

The following is a sample problem for computing container space requirements in a marshaling area: your unit has been tasked to operate a container terminal with a total marshaling area of 830 feet wide and 886 feet long. The area must be designed for a one-ship operation using the sideloader in the stacking clusters.

To satisfy operational requirements, the stacking method must be used to enhance selective extraction. You are to determine the intrinsic capacity of the marshaling area using Figures 6-21 (page 6-30) and 6-22 (page 6-31). Also use Figures 6-21 and 6-22 to perform the following steps:

Step 1. Layout a plan of the area.

- Draw a rectangle representing the area.
- Draw in surrounding intersecting aisles.
- Draw in through intersecting aisles.
- Determine measurements of clusters.

Step 2. Determine the number of 20-foot containers in each row.

- Determine how many 20-foot containers will fit into each row, by dividing 340 by 20.5 (.5 equals half-foot space allowed between containers for working room). This equals 16.58 containers per row. Any fraction is not counted a container; therefore, .58 is lost space (.58 x 20.5 = 11.89 feet). To provide more aisle space, move containers 10 feet to the left or right.

- Stack containers (turret stacking) in two-/two-/one-high sequence in any given row. Every three ground slots have a five-container capacity. To determine the number of containers in a row, divide the number of columns by 3. Multiply that product by 5. If 3 does not divide evenly into the number of columns, the remainder is multiplied by 2 and added to the previous product. For example:

16 columns divided by 3 = 5 (with a remainder of 1)

$5 \times 5 = 25$

1 (remainder) x 2 = 2

$25 + 2 =$ intrinsic capacity of 27 TEUs per row in areas A and B

Add the 10 feet of unused space to areas C and D. Repeat the calculation set forth in the previous paragraphs. For example:

350 divided by 20.5 = 17.073 containers per row

$073 \times 20.5 = 1.5$ feet

17 divided by 3 = 5 (with a remainder of 2)

$5 \times 5 = 25$ containers

2 (remainder) x 2 = 4

$25 + 4 = 29$ TEUs per row with 1.5 feet of unused space in areas C and D

Step 3. Determine the number of rows.

□ Stacking 8-foot wide containers side by side in double rows with a rolling space of .5 feet between the rows would occupy 16.5 feet. The sideloader requires a 15-foot working aisle. So in every 30.5 feet are stacked two rows. The length of this area is 368 feet, divided by 30.5 feet equals 11.65 or 11 double rows, with 21 feet remaining between a working aisle and an intersecting aisle.

q Using the intersecting aisle to work from would allow 16.5 feet of the 21 to be used for a further double row, for a total of 12 double rows.

NOTE

Each double row in A and B has 64 TEUs. Each double row in C and D has 68 TEUs. A and B each contain 64 TEUs multiplied by 12 double rows. This equals 646 TEUs in each quadrant. A and B together contain 1,296 TEUs. C and D each contain 68 TEUs multiplied by 12 rows. This equals 696 TEUs in each quadrant. C and D together contain 1,392 TEUs. A and B (1,296 TEUs) plus C and D (1,392 TEUs) equals an intrinsic capacity of 2,688 TEUs. The optimum operating capacity is 66 percent of 2,688 or 1,478 TEUs.

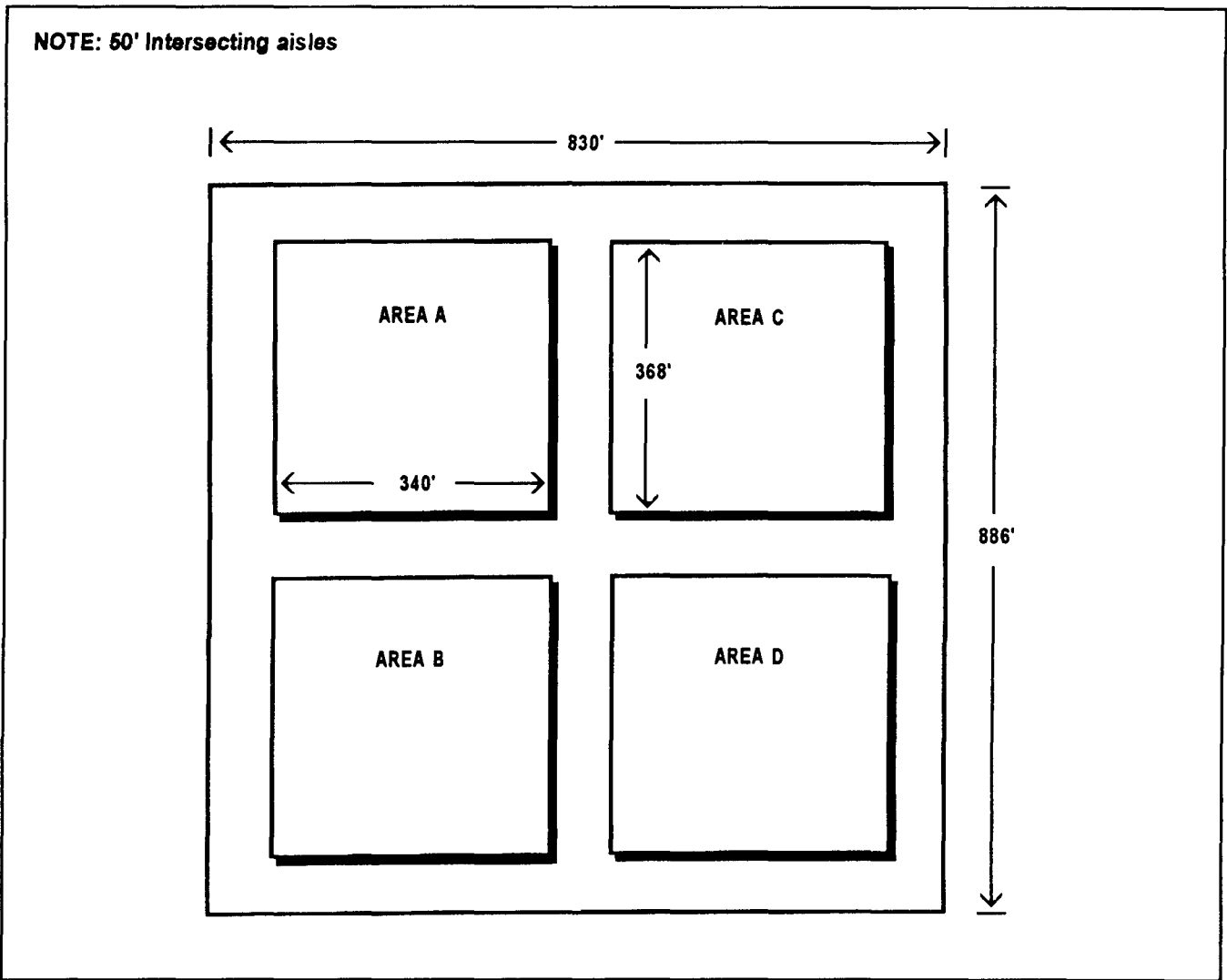

Figure 6-21. Sample layout plan for container space requirements in a marshaling yard

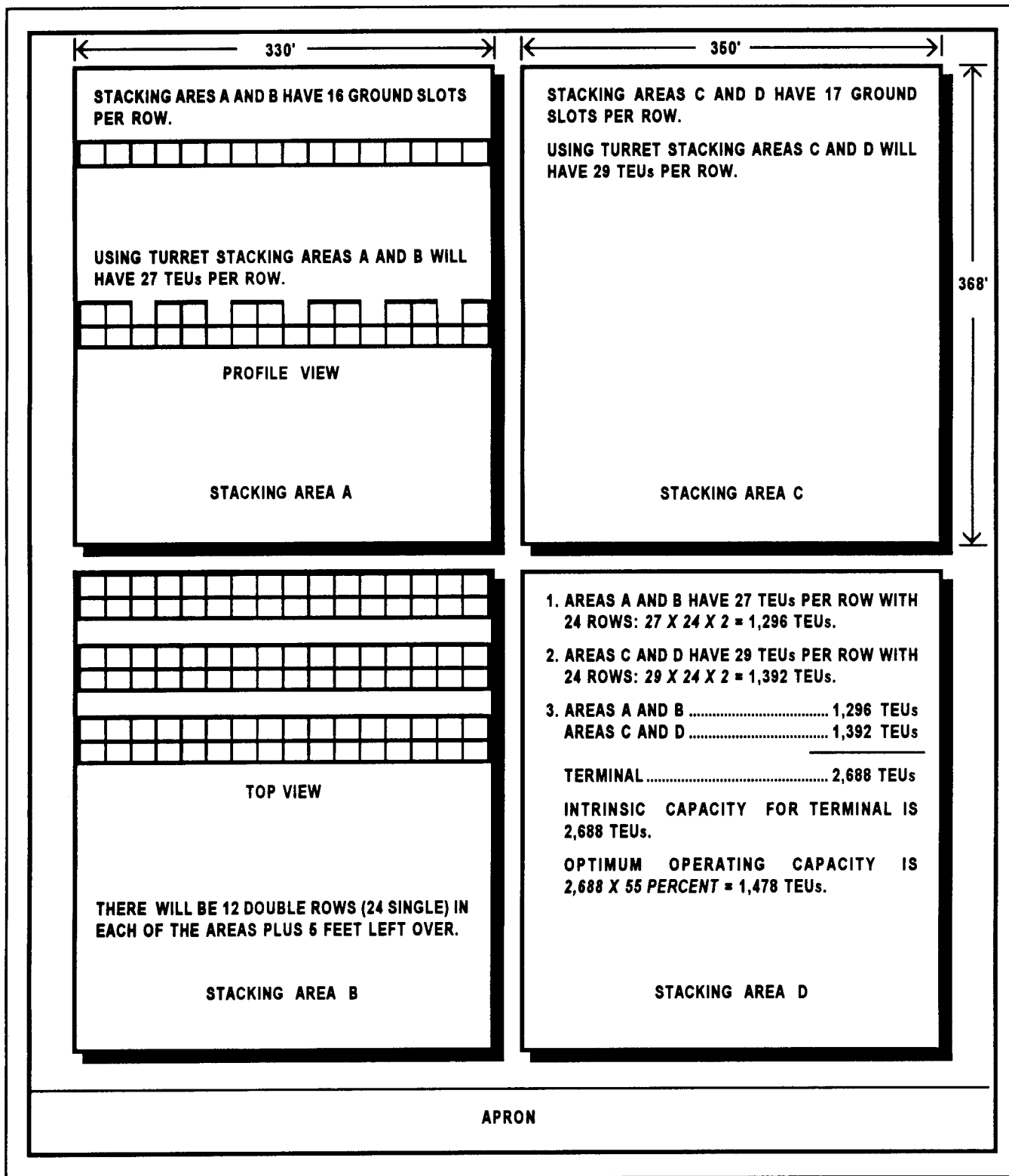
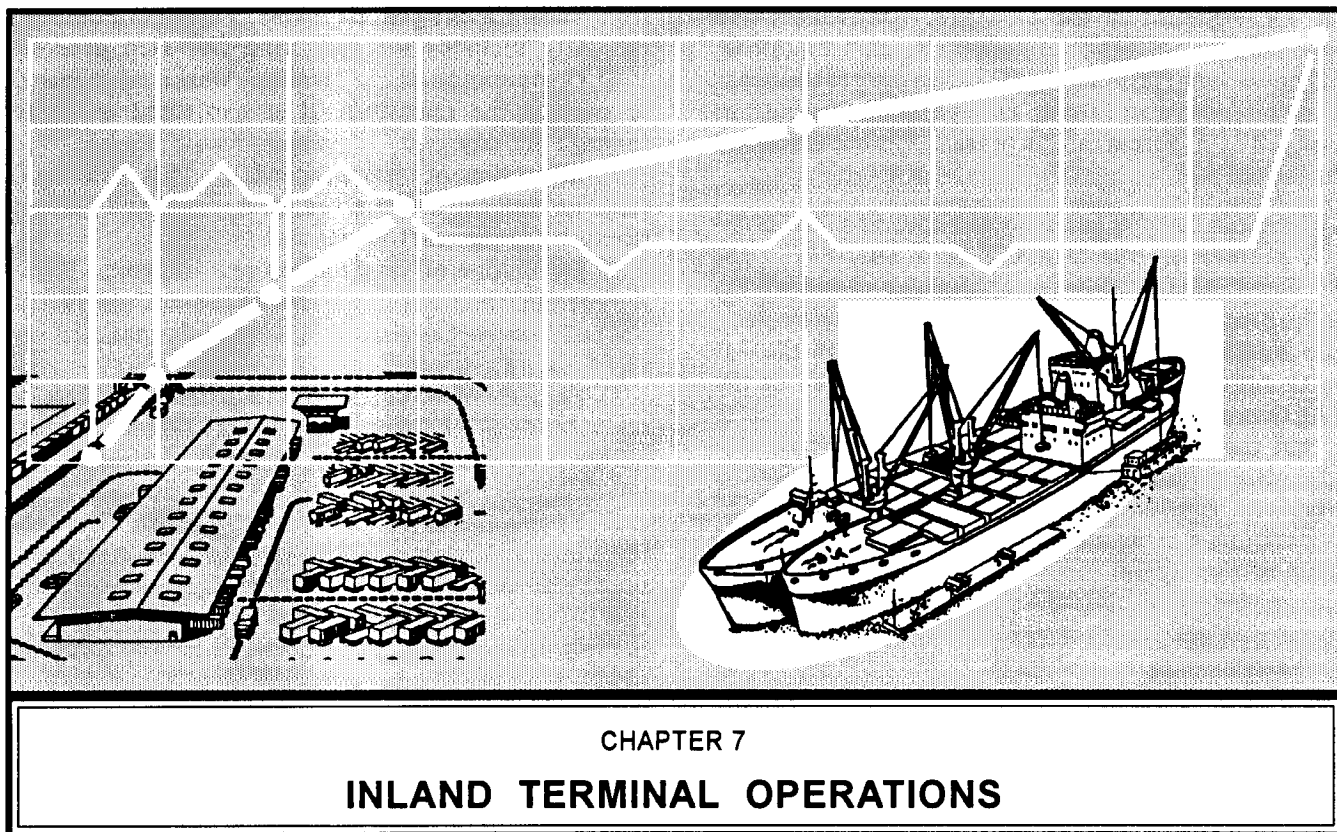

Figure 6-22. Partially completed layout plan for container space requirements in a marshaling yard



INTRODUCTION

Inland terminals are established at both ends of and at interchange points along theater air, rail, and motor transport systems. They transship cargo and personnel carried by these modes. Army cargo handling at these inland terminals is a main function of the transportation cargo transfer company (TOE 55-8 17). Normally, the mode battalion or group having primary transport responsibility for the system, operates and controls the entire inland terminal facility. Transportation cargo transfer companies are attached to these elements for operational control. In the case of terminal cargo companies or elements employed at Air Force air terminals, the cargo transfer company is normally attached to the mode operating battalion responsible for clearing cargo from the air terminal.

In most situations, motor and air transport are the main transport services. Inland transfer operations are

conducted chiefly at terminals and transfer points serving those modes. These terminals are established throughout COMMZ, corps, and division rear areas, as required, to provide an adequate transportation service. If usable terminal facilities exist, they are incorporated into the transportation network. Since transportation must respond to CSS needs, cargo transfer activities normally occur under austere circumstances. Terminals serving rail and inland waterways are established along existing operable routes and, in the case of rail, with available and operable rolling stock and facilities. Movements by water and rail are more economical, respectively, than motor and air.

The cargo transfer company conducts cargo transfer operations at inland terminals. They are supervised by the transportation brigade in the COSCOM and by the

TA TRANSCOM in the COMMZ. Assignment and attachment, command relationships, unit functions, and operational techniques vary according to the needs of the respective terminals. The operational variations imposed by different modes of transport are discussed in this chapter.

The cargo transfer company can operate at air terminals performing the DACG/AACG missions. The mission of the DACG is to coordinate and control the outloading of units for deployment or redeployment. The DACG is the deploying units link with the Air Force for loading the aircraft. The mission of the AACG is essentially the same as that for the DACG, except that the AACG is primarily concerned with offloading operations. If practical for the AACG mission, the cargo transfer company will be prepositioned at the arrival airfield. Otherwise, it will move to the arrival airfield in lead elements of the transported force. The DACG or AACG is the transported unit's point of contact with the Air Force ALCE at the departure or arrival airfield. All personnel responsible for supervision of the outload must be thoroughly familiar with the loading procedures applicable to the types of aircraft to be loaded. Where practical, the marshaling/outload area should be surveyed by the DACG or AACG. The survey will provide current and accurate information on facilities available and support required. For detailed information on DACG/AACG operations, see FM 55-12.

The transportation group provides transportation support. It deploys its units to provide local haul and line-haul transportation support, transportation movements management, and terminal facilities. The structure of the transportation group is tailored to match the particular support requirements. The number of subordinate units, including cargo transfer companies, varies according to the situation. Essentially, the group transport units connect the transportation intersectional services with support maintenance. The group also provides forward-moving transportation for cargo delivered by Air Force aircraft into the service area.

STAFF AND UNIT PLANNING

A determination of the numbers, types, and locations of terminals within the theater results

from staff planning at all levels. Terminal planning normally includes the following five-step process:

- Computation of the terminal workload required to support the operation. It is expressed as cargo tonnage per day.
- Estimation of terminal capacity. This is the total tonnage that can be received, processed, and cleared through the terminal in one day.
- Estimation of construction requirements. These are the requirements to repair and rehabilitate facilities and construct new facilities so the terminal capacity can equal the required terminal workload.
- Estimation of equipment requirements. This is the amount of equipment needed to process the required workload through the terminal with maximum efficiency.
- Estimation of personnel requirements. These are the units and individuals needed to administer and operate the terminal processing the required workload. FM 101-10-1/2 contains a detailed checklist for estimating inland terminal capacity. It details terminal planning at staff level.

Unit level planning begins when a company is tasked to perform cargo transfer functions at a specific site. If the terminal facility exists before a cargo transfer company or its elements is assigned, initial procedures include a meeting between the transfer unit and the transport mode commanders to define and determine mutual support requirements. The meeting is followed by a joint inspection of the terminal area to acquaint the transfer unit commander with the layout. Tentative real estate allocations for all units to operate at or from the proposed terminal are normally made during this area reconnaissance.

OPERATIONAL PLANNING

Once the area and general mission are assigned, the unit commander must consider various factors that provide the basis for operational planning. The following are the factors he must consider.

- He must consider the physical characteristics and layout of the terminal area including the following:
 - Physical restrictions on working space.
 - Availability of hard surfaces in transfer areas.
 - Existing facilities for storage and maintenance of MHE and other equipment.

- Proximity of exit routes to transfer points.
- Distances between loading and unloading points and temporary holding areas.
- He must consider the characteristics of the transportation equipment including the following:
 - Number of individual carriers that can be handled simultaneously.
 - Turnaround time of delivery transportation.
 - Unit loading and unloading rates for various types of transportation.
 - Effects of size and maneuverability of carriers on the location of transfer points within the terminal.
 - Effects on use of and requirements for MHE.
- He must consider the types of cargo to be handled including the following:
 - Size and type of packaging.
 - Average weights of cargo units.
 - Requirements to break down into smaller lots or consolidate for reloading.
 - Shelter and security protective requirements in in-transit storage areas.
 - Fragility and/or perishability.
 - Problems involved in and precautions for handling hazardous cargo.
- He must consider the requirements for and selection of temporary in-transit storage areas including the following:
 - Estimated availability of clearance transportation compared with the volume of delivery transportation.
 - Shelter and security requirements.
 - Additional documentation required.
 - Distances from loading and unloading points.
 - Requirements for MHE in the holding area.
- He must consider the composition of the work force including the following:
 - Number and size of teams required.
 - Allocation of MHE according to the types of carriers and types of cargo.
 - Arrangement of shifts for around-the-clock operations.
 - Provisions for consolidating documentation.
- He must consider establishing unit procedures for documentation, communications, supply, safety, and maintenance of equipment. He must consider the provisions for area defense and damage control based on overall terminal area plans.
- He must also consider unit procedures for complying with applicable federal, state, local, and

HN environmental regulations; including but not limited to spill contingency planning, waste disposal, and site specific environmental concerns.

PERSONNEL AND EQUIPMENT REQUIREMENTS

Time studies of cargo-handling operations indicate that the following are valid averages for long-range planning purposes.

□ When cargo must be handled entirely by hand, personnel requirements can be computed on the average of 1/2 ton per man-hour for a 10-hour shift. Divide the daily tonnage by the shift length multiplied by the man-hour tonnage capabilities. For example, the number of men required to handle 120 STONs of cargo per 10-hour shift is computed as follows:

$$\begin{aligned}
 &= \frac{\text{Daily tonnage}}{\text{Shift lengths in hours} \times \text{man-hour capability in tons per given shift}} \\
 &= \frac{120}{10 \times 1/2} \\
 &= \frac{120}{5} = 24 \text{ (personnel required)}
 \end{aligned}$$

NOTE

This formula is valid only for the normal 10-hour shift where the daily tonnage requirement is expected to remain constant. It includes the working supervisors but does not provide for documentation of the cargo. Generally, one cargo checker per shift is sufficient at each loading or unloading site. However, terminal transfer unit cargo handlers should be trained as checkers to meet additional requirements if they occur.

□ Normally, a maximum of five men can effectively load or unload an Army aircraft or truck by hand. This crew consists of a working foreman and four cargo handlers or half a squad. Two of the men work in the cargo compartment of the carrier and the other two work on the ground, loading platform, or

another carrier involved in the cargo transfer. The foreman divides his time between the two groups and assists as needed. One squad can load or unload two trucks or two aircraft by hand if the carriers are located close enough together that the squad leader and the single cargo checker can properly perform their duties at each location.

- ❑ An entire cargo transfer squad (four men working the car and four on the outside) is required to load or unload a railcar by hand or augmented by MHE. The supervisor and checker assist as required.

- ❑ Because inland waterway craft do not normally carry cargo that can be entirely manhandled, full use of the equipment platoon and the cargo equipment squads is required in this type of operation.

- ❑ Cargo should be transferred mechanically when supplies are unitized and the MHE is compatible with the carriers. For planning purposes, personnel requirements to mechanically handle cargo by such equipment as rough terrain forklifts, cranes, and/or tractor-trailers are usually limited to an operator for each piece of MHE, a checker, and appropriate supervisory personnel.

AIR TERMINALS

Air cargo transfer operations within the theater take place at Air Force and Army air terminals. The Air Force commander must provide terminal facilities at all points served by the AMC or tactical airlift aircraft. This includes loading and unloading the aircraft and Army clearance and delivery transport equipment. However, the Army commander may, by local agreement, provide personnel to help load and unload Army transportation at these facilities. He may also accept responsibility for loading and unloading Air Force aircraft at forward landing fields or airstrips that are not a regularly scheduled stop for tactical airlift aircraft. Each of these situations uses the cargo transfer company or its elements. The transfer company or its elements may also furnish personnel to load and unload Air Force tactical airlift aircraft conducting Army unit moves (see FM 55-12). The cargo transfer company is required to accept cargo from the Air Force pending CDI. It may provide break-bulk facilities for consolidated shipments and cargo awaiting Army transport. The transfer company may also operate a consolidating point for retrograde air shipments.

The COSCOM establishes and operates Army air terminals in corps areas to support Army ALOC. Facilities and services are provided at these terminals for timely and effective air movement of personnel and supplies and for efficient use of available aircraft. The senior Army officer of the transport units operating at these points normally acts as the terminal commander. Cargo transfer units load and unload aircraft, document cargo moving through the terminal, and operate cargo segregation and temporary holding facilities. The MCT located at or near the terminal coordinates the flow of cargo and passengers into and out of the airlift system. When Army aircraft are used in a local distribution operation, shipping and receiving agencies (rather than the cargo transfer company) must load and unload the aircraft.

At division level, the DISCOM is responsible for air terminal operations. It establishes one or more air terminals according to the volume of cargo received or distributed by air. Normally, the supply and transport battalion operates division air terminals. However, elements of the cargo transfer company may be transported by air to forward airstrips to unload cargo for limited periods.

Cargo transfer companies or their elements are assigned to air terminals on the basis of the daily tonnage to be moved through a terminal. To obtain a smooth flow of cargo through these terminals, the capacities of clearance and delivery transport equipment must be balanced with the transfer capability. The ideal situation is when cargo moves through and out of the terminal at the same rate that it comes in. This seldom occurs however, because movement of priority cargo overrides the first-in, first-out concept. If the backlog becomes too great, throughput capacity of the terminal is reduced due to the increase in cargo-handling within the holding areas. In all situations, every effort must be made to ensure that cargo availability and clearance transportation are equal to the tonnage requirements of the ultimate user.

Most air cargo is unitized on 463L pallets. The transfer unit's forklifts unload and move cargo from the aircraft unloading point to clearance transportation or temporary holding areas. Forklifts and cranes load or unload surface transportation. Cargo discharge from aircraft is frequently consolidated to most efficiently use the heavier CHE. Conversely, cargo

unloaded from surface carriers may have to be segregated and prepared into units compatible with aircraft space and weight capacities.

The cargo transfer company also has a variety of slings and nets to rig external loads for helicopter delivery. Arrangements must be made for periodic return of these items so that a sufficient supply is always available in the terminal.

MOTOR TRANSPORT TERMINALS

Motor transport terminals are normally located at both ends of a line-haul operation. They form the connecting link between local hauls and the line-haul service. They may also be located at intermediate points along the line-haul route where terrain necessitates a change in type of carrier. Cargo transfer elements provide cargo-handling service at motor transport terminals. The senior motor transport commander operationally controls them. DISCOM personnel are responsible for cargo transfer at forward terminals.

Motor transport unit capabilities range from 720 to 2,160 STONs per company, per day for local hauls and from 360 to 1,080 STONs per day for line-haul operations. (Motor transport operations are detailed in FM 55-30.) Therefore, cargo transfer requirements at motor transport terminals range from an augmented platoon (additional squads) to two augmented companies (additional platoons), depending on the number of truck units operating through the terminals. If cargo transiting the motor transport terminal is containerized, the facility may be recognized as a motor transport container terminal. With this configuration of cargo, the cargo transfer capability will require CHE.

Based on the planning factors noted above, a full-strength cargo transfer company can discharge 12 trucks at a time when employed on a 10-hour per day basis. Light and medium truck companies operate with an average availability of 45 vehicles. Each company makes four trips per day in local-haul operations and two trips per day in line-haul operations. To permit the truck units to maintain this turnaround schedule, each transfer squad must load or unload an average of one truck per hour. At normal manual handling rates, this average can be maintained with

relative ease, particularly when using 2 1/2-ton trucks. However, when heavier vehicles are used, the unit commander must ensure that handling rates keep pace with the truck turnaround schedules. He must carefully allocate the unit's heavier CHE among the squads to minimize delays at each transfer point.

RAIL TERMINALS

Rail terminals may include yard tracks, repair and servicing facilities, train crew accommodations, and railheads. They are located at originating and terminating points and at sites that mark the limits of rail operating divisions. A railhead can be any size yard or terminal on or at the forward end of a military railway where personnel, supplies, and equipment are transferred to other modes of transportation for further movement forward.

Army and/or HN rail units provide an intersectional transportation service. The Army units are assigned to TA TRANSCOM. The transportation composite group (TOE 55-622L) exercises command and control. Rail capability within the field Army will be exploited whenever usable facilities exist, provided tactical situations are favorable. The fluidity of the front, ability to maintain air superiority, extent of guerrilla activity, and attitude of the local populace are some of the factors that affect the decision to use rail units and the extent of their use in the CZ.

Cargo transfer units at terminating railheads in the field Army area, transfer cargo delivered from COMMZ depots and terminals to forward-moving COSCOM transportation. When so employed, the transfer unit works with the railway detachment operating the terminal. But, the COSCOM transport organization responsible for further forward movement of the cargo operationally controls the unit.

The transfer unit's heavier CHE, particularly the 20-ton rough terrain cranes, are used to the maximum at rail terminals. In general, the cranes unload vehicles and other heavy equipment from flatcars and gondolas. Forklifts and conveyors unload boxcars. Heavier cargo items and containers are handled in large proportions at rail terminals. However, the increased requirement for temporary holding and cargo breakdown and repackaging may lower

average handling rates. This factor should be considered when throughput and clearance capacities are being computed.

One cargo transfer squad, appropriately augmented with MHE, is employed to unload each railcar. Although the capacities of US railcars average 50 tons each, 75 to 80 percent of the cars used in overseas theaters will be local equipment, most rated in the 15- to 30-ton range. Generally, railcars loaded with heavy, bulky items such as ammunition, barbed wire, cement, vehicles, packaged weapons, and tools are loaded to rated capacity. However, when the cargo is made up of such items as rations, clothing, and tentage, loads average from 50 to 75 percent of the car's rated capacity.

INLAND WATERWAY TERMINALS

Cargo transfer units are employed only at small intermediate cargo transfer points on IWWs. Limitations on their use at these points are the size and configuration of the waterway craft and capabilities and capacities of the unit's CHE. When the waterway delivery is composed largely of barges, landing craft, and similar types of floating equipment, the cargo transfer company may be used in the transshipping process. However, when larger, ocean-type shipping is operated, transportation terminal service companies (TOE 55-818L) must be assigned for loading and discharge. In the latter situation, the cargo transfer unit may be assigned to support terminal service company shore platoons.

Generally, if the waterway originates in the corps area, the cargo transfer company is attached to the organization operating the waterway. However, if the waterway system originates in the COMMZ and is part of the intersectional transportation service, the commander providing clearance transportation, operationally controls the transfer unit in the corps area. In retrograde operations, this scheme of command and control does not change.

PERSONNEL MOVEMENTS

The transportation cargo transfer company is designed to function primarily in cargo transfer operations. However, it may on occasion be required to help move personnel through a terminal to which it is

assigned. Such situations include intraterminal unit moves; patient evacuations; and prisoners of war, refugees, and displaced persons.

Intraterminal Unit Moves

When requested by the troop movement officer or the terminal commander, transfer company personnel can help process a unit through the terminal. They can serve as guides. They can provide transport and MHE to move personnel and equipment from the point of debarkation to the loading area.

Patient Evacuations

Terminal transfer personnel may help evacuate patients only upon request from the senior medical representative responsible for transferring of the patients. He and his assistants direct the manner of the evacuation. Extreme care must be exercised when moving the sick and injured. Personnel untrained in this duty should not be used. However, the transfer operation can be materially aided. Unit personnel can serve as terminal guides and assistants in loading and unloading accompanying supplies and equipment.

Prisoners of War, Refugees, and Displaced Persons

Intraterminal movements of persons in these categories are conducted under the control and supervision of MP and/or civil affairs personnel. When requested, members of the cargo transfer company may serve as guards, guides, or interpreters and may help move property, supplies, and equipment.

DOCUMENTATION

The cargo transfer company uses manual or automated cargo documentation for various purposes. Cargo must be receipted when it arrives at the terminal, is cleared forward, and is stored in a temporary holding area. Records of all shipment units handled are kept using the documentation and procedures required by DOD Regulation 4500.32-R, Volumes I and II and locally produced inventories and registers.

The checker is responsible for tallying cargo actually received against the documentation. He records the transshipment and notes discrepancies, damages, and improper or insufficient markings using the TCMD or electronic equipment (LOGMARS).

Hard copy reports produced by the documentation section ensure high in-transit visibility and a clear audit trail of cargo. When the cargo is ready for forwarding from the terminal, the documentation is updated to reflect any consolidation that has occurred. This information is given to the checkers who document the cargo as it leaves the terminal. Completed records are retained at the terminal. Additional forms and documentation procedures that may be required in the theater are specified in appropriate directives.

APPENDIX A

**EXTRACT OF STANAG 2166
MOVEMENTS AND TRANSPORT DOCUMENTS
USED FOR MOVEMENTS
BY SHIP**

This appendix includes an extract of STANAG 2166 (Movements and Transport Documents Used for Movements by Ship). This appendix is implemented by Chapter 3 (Marine Terminal Operations). STANAG 2166 contains standardized movement and transport documents for ship transport.

NATO UNCLASSIFIED

Agreed English/French texts

STANAG 2166
(Edition 3)
NAVY/ARMY/AIR

NATO STANDARDIZATION AGREEMENT
(STANAG)

MOVEMENTS AND TRANSPORT DOCUMENTS USED FOR MOVEMENTS BY SHIP

- Annexes : A. Cargo Traffic Message
 B. Sailing Signal - Load Advice
 C. Sea Movement Resource Signal
 D. Cargo Stowage Plan
- Related Documents : STANAG 2023 MMS - Marking of Military Cargo for International Movement by all International Means of Transport
 STANAG 2155 M&T - Road Movement Bid and Credit
 STANAG 2156 M&T - Surface Transport Request and Surface Transport Reply
 STANAG 2165 M&T - Forecast Movement/Transport Requirements - Rail, Road and Inland Waterways

AIM

1. The aim of this agreement is to standardize the essential movements and transport documents used for the movement of materials by ship to and from NATO nations so that loading and discharge can be carried out efficiently. Cargo is forwarded from ports and beaches to the final destination in accordance with STANAGs 2155, 2156, and 2165.

AGREEMENT

2. Participating nations agree to adopt the following documents for movement of material by ship between NATO nations.

- a. Cargo Traffic Message : See Annex A
- b. Sailing Signal - Load Advice : See Annex B
- c. Sea Movement Resource Signal : See Annex C
- d. Cargo Stowage Plan : See Annex D

DEFINITION

3. The following term and definition are used for the purpose of this agreement:

Net Explosives Quantity (NEQ)

The quantity in kilograms of the explosive substance present in a container, ammunition, building, etc. It does not include such substances as white phosphorous, war gases, or smoke and incendiary composition unless the substances contribute significantly to the dominant hazard of the Hazard Division concerned.

NATO UNCLASSIFIEDDETAILS OF THE AGREEMENT

4. When vessel sailing time from the Port of Embarkation to the Port of Debarkation is more than 72 hours, the Cargo Traffic Message, Annex A, is to be dispatched. When vessel sailing time is less than 72 hours, the Sailing Signal - Load Advice, Annex B, or Sea Movement Resource Signal, Annex C, is to be dispatched as deemed appropriate by the sender. Annex C is used to advise movement staffs and naval shipping control authorities of the allocation of shipping and its schedule following the activation of plans. It gives advance notice of arrival times and cargo details to enable reception planning to begin.

IMPLEMENTATION OF THE AGREEMENT

5. This STANAG is implemented when the necessary orders/instructions to use the documents mentioned in this agreement have been issued to the forces concerned. Annexes A, B, and C are not to be used as a substitute for a ships cargo manifest.

-2-

2166.E2/
114pt

NATO UNCLASSIFIED

NATO UNCLASSIFIED

ANNEX A TO
STANAG 2166
(Edition 3)

- Appendices : 1. Specimen Cargo Traffic Message
2. Vessel Stowage Location Codes
3. Abbreviations/Acronyms

CARGO TRAFFIC MESSAGE

1. Movements staffs at the port of loading will dispatch a Cargo Traffic Message (CTM) for each ship carrying military cargo as soon as loading is completed. The CTM will be dispatched to each port of discharge. When any portion of the CTM is classified, the entire CTM will be classified appropriately.

2. Instructions for preparing the CTM are given below. A specimen CTM is shown at Appendix I.

- a. Precedence. CTMs will be assigned a precedence in accordance with existing NATO procedures.
- b. Security Classification. The originator will insert the appropriate security classification.
- c. Text
 - (1) Paragraph 1. Ship Identification
 - (a) Ship prefix, e.g., USS, USNS, USCG, SS, MS, MV, NS.
 - (b) Ship name or number.
 - (c) Voyage number.
 - (d) Vessel terms of carriage (status code (US only)).
 - (e) International Radio Call Sign (IRCS).
 - (f) Type commercial ship (vessel classification), e.g., C1, C2, C4, LASH, SEABEE, RORO.
 - (2) Paragraph 2. Movement Data
 - (a) Departure port.
 - (b) Departure hour/day (ZULU date time group).
 - (c) Next port of call.
 - (d) Estimated Time of Arrival (ETA) next port of call (date).
 - (e) Subsequent ports of call (for loading and discharge) where cargo operations will be conducted.

A-1

2166.EA1/
114pt

NATO UNCLASSIFIED

NATO UNCLASSIFIED

- (3) Paragraph 3. Operational Handling Information
- (a) Ship characteristics (self-sustaining, non-self-sustaining, etc.).
 - (b) Special berthing requirements.
 - (c) Special information if required by theater or host nation port area commander, e.g., expected arrival draft, overall length, beam and capacity in metric tonnes (M.T.) and cubic metres (cu. m.) (US only: include long tons (L/T) and measurement tons (M/T) in parentheses, followed by abbreviation, e.g., (40 L/T, 10 M/T)).
 - (d) "Manifest on Board" or "Manifest Forwarded Separately" by method, e.g., AUTODIN (US only), mail, etc. .
 - (e) "Cargo for Trans-shipment at (port of discharge)", when applicable.
- (4) Paragraph 4. Total cargo loaded in metric tonnes (M.T.) and cubic metres (cu.m.) (US only: include long tons (L/T) and measurement tons (M/T) in parentheses, followed by abbreviation, e.g., (40 L/T, 10 M/T).
- (5) Paragraph 5. For each port of discharge, include a separate paragraph with total cargo loaded for that part in metric tonnes (M.T.) and cubic metres (cu.m.) (US only: include long tons (L/T) and measurement tons (M/T) in parentheses, followed by abbreviation, e.g., (40 L/T, 10 M/T) and a summary as follows (excluding cargo for trans-shipment).
- (a) Deck load by military service (or consignee when appropriate) description (include number of wheeled and number of tracked vehicles), metric tonnes (M.T.) and cubic metres (cu.m.) (US only: include long tons (L/T) and measurement tons (M/T) in parentheses, followed by abbreviation, e.g., (40 L/T, 10 M/T), excluding ammunition/explosives.*)
 - (b) Hatch load by military service (or consignee when appropriate) description (include number of wheeled and number of tracked vehicles), metric tonnes (M.T.) and cubic metres (cu.m.) (US only: include long tons (L/T) and measurement tons (M/T) in parentheses, followed by abbreviation, e.g., (40 L/T, 10 M/T), excluding ammunition/explosives.*)

*) Identified by the first three positions of the vessel stowage location code
(Appendix 2) indicates stowage location for LASH/SEABEE vessels by the last
 four positions of the barge number.

A-2

2166.EA2

NATO UNCLASSIFIED

NATO UNCLASSIFIED

- (c) Total number of refrigerated (REEFER) containers for each military service (or consignee when appropriate) metric tonnes (M.T.) and cubic metres (cu.m.) (US only: include long tons (L/T) and measurement tons (M/T) in parentheses, followed by abbreviation, e.g., (40 L/T, 10 M/T).
- (d) Total number of other containers (SEAVANs, MILVANs, MSCVANs) for each military service (or consignee when appropriate) metric tonnes (M.T.) and cubic metres (cu.m.) (US only: include long tons (L/T) and measurement tons (M/T) in parentheses, followed by abbreviation, e.g., (40 L/T, 10 M/T), excluding those containing ammunition/explosives.*)
- (e) Total number of containers (SEAVANs, MILVANs, MSCVANs) containing ammunition/explosives for each military service (or consignee when appropriate) metric tonnes (M.T.), cubic metres (cu.m.) (US only: include long tons (L/T) and measurement tons (M/T) in parentheses, followed by abbreviation, e.g., (40 L/T, 10 M/T) and Net Explosive Quantity (NEQ) by UN Code (International Maritime Dangerous Goods (IMDG) Code) UN Code to include decimal fraction sub-division, e.g., 1.1, 1.2, IMDG compatibility group code, and stow location.
- (f) Description of bulk ammunition/explosives for each military service (or consignee when appropriate) metric tonnes (L/T) and measurement tons (M/T) in parentheses, followed by abbreviation, e.g., (40 L/T, 10 M/T), Net Explosive Quantity (NEQ) by UN Code (International Maritime Dangerous Goods (IMDG) Code) UN Code to include decimal fraction sub-division, e.g., 1.1, 1.2, IMDG compatibility group code, and stow location.
- (g) Heavy lift cargo exceeding the capacity of the ships booms, number of pieces, stow location, weight (metric tonnes (M.T.)) (US only: include long tons (L/T) and measurement tons (M/T) in parentheses, followed by abbreviation, e.g., (40 L/T, 10 M/T).
- (h) Protected (sensitive) and/or classified cargo number of pieces stow location, identification number (for US, use Transportation Control Number).
- (i) For LASH/SEABEE shipments, list all barges by number, by military service (or consignee when appropriate) and indicate cargo description(including summary of containers as indicated above, if applicable) in metric tonnes (M.T.) and cubic metres (cu.m.) (US only: include long tons (L/T) and measurement tons (M/T) in parentheses, followed by abbreviation, e.g., (40 L/T, 10 M/T).

*) Identified by the first three positions of the vessel stowage location code (Appendix 2) indicates stowage location for LASH/SEABEE vessels by the last four positions of the barge number.

NATO UNCLASSIFIED

- (6) Final paragraph. Trans-shipment Data (As required).
- (a) Port of trans-shipment.
 - (b) Information specifying responsibility for trans-shipment of cargo.
 - (c) Name of on-carrying vessel (indicate vessel TBN (to be named) if unknown).
 - (d) Cargo data as required in Instruction 5 for each port of discharge.
 - (e) For LASH/SEABEE shipments, the port of trans-shipment is the port of discharge of the vessel. For movement of barge from vessel port of discharge to inland barge port of discharge, indicate "TOWED" in lieu of name of on-carry vessel. Summarize cargo data by barge number and barge port of discharge.

A-4

2166.EA4/
114ptNATO UNCLASSIFIED

NATO UNCLASSIFIED

APPENDIX 1 TO
ANNEX A TO
STANAG 2166
 (Edition 3)

SPECIMEN CARGO TRAFFIC MESSAGE

A. BREAKBULK

FROM : Preparing Activity
 TO : Receiving Activity (Other addressees as required)

UNCLASSIFIED

SUBJECT : Cargo Traffic Message

1. USNS Comet / A-1893 / 11 / KCMV / C4.
2. Departed Bayonne NJ 160940Z May for Antwerp ETA 24 May. Subsequent port Rotterdam.
3. Self-sustaining. Manifest forwarded separately via AUTODIN.
4. Total cargo loaded 1970 M.T., 7268 cu.m. (1940 L/T, 6418 M/T).
5. Total cargo loaded for Antwerp 1095 M.T., 4063 cu.m. (1078 L/T, 3588 M/T).

<u>Location</u>	<u>Military Service/ Consignee</u>	<u>Number of Vehicles</u>	<u>M.T.</u>		<u>cu.m.</u>	
1LH	Army General		26	66	(26 L/T,	59 M/T)
1LT	Army General		14	36	(14 L/T,	32 M/T)
3LH	Army Wheeled Vehicles	14	85	428	(84 L/T,	378 M/T)
3UT	Army Wheeled Vehicles	11	111	573	(110 L/T,	506 M/T)
3LT	Army Wheeled Vehicles	36	365	1875	(360 L/T,	1656 M/T)
3UD	Army Wheeled Vehicles	11	491	1083	(484 L/T,	957 M/T)

6. Total cargo loaded for Rotterdam 875 M.T., 3205 cu.m. (862 L/T, 2830 M/T).

4LH	Army Wheeled Vehicles	12	73	366	(72 L/T,	324 M/T)
4LT	Army Wheeled Vehicles	23	233	1198	(230 L/T,	1058 M/T)
4UT	Army Wheeled Vehicles	47	477	1437	(470 L/T,	1269 M/T)
4MD	Army Tracked Vehicles	2	89	197	(88 L/T,	174 M/T)
4MD	Army Hazardous, UN Class 1.2 D, NEQ 1851 kg		2	5	(2 L/T,	5 M/T)
4SL	TCN W253414031XXX Army General		5	pcs		

A-1-1

EZ166.EA5/
114pt

NATO UNCLASSIFIED

NATO UNCLASSIFIED

SPECIMEN CARGO TRAFFIC MESSAGE
(Specimen/SEAVANs)

B. SEAVANs

FROM : Preparing Activity
TO : Receiving Activity (Other addressees as required)

UNCLASSIFIED

SUBJECT : Cargo Traffic Message

1. SS American Lancer / A-1899 / W2 / WZJB / C4.
2. Departed Charleston SC 250630Z May for Bremerhaven ETA 2 June.
3. Non-self-sustaining. Manifest forwarded separately via AUTODIN. Cargo for trans-shipment at Bremerhaven.
4. Total cargo loaded 29 SEAVANs 257 M.T., 1566 cu.m. (253 L/T, 1382 M/T).
5. Total cargo loaded for Bremerhaven 240 M.T., 1526 cu.m. (237 L/T, 1348 M/T).

4 Reefer SEAVANs (30 L/T, 98 M/T)	Army General	39 M.T.	111 cu.m.
24 SEAVANs (198 L/T, 1250 M/T)	Army General	201 M.T.	1415 cu.m.
6. Cargo for trans-shipment at Bremerhaven to Esbjerg via TBN.

1 Reefer SEAVAN (16 L/T, 35 M/T)	Navy General	16 M.T.	39 cu.m.
-------------------------------------	--------------	---------	----------

A-1-2

2166.EA6/
14pt

NATO UNCLASSIFIED

NATO UNCLASSIFIED

SPECIMEN CARGO TRAFFIC MESSAGE

C. LASH/SEABEE

FROM : Preparing Activity
TO : Receiving Activity (Other addressees as required)

UNCLASSIFIED

SUBJECT : Cargo Traffic Message

1. SS Doctor Lykes / A-1897 / W / KHNB / SEABEE.
2. Departed Galveston TX 201645Z May for Rotterdam ETA 29 May.
3. Non-self-sustaining. Manifest forwarded separately via AUTODIN.
4. Total cargo loaded 91 M.T., 207 cu.m. (90 L/T, 183 M/T).
5. For Mannheim via Rotterdam (towed) 91 M.T., 207 cu.m. (90 L/T, 183 M/T).

Bargo No. 0006 Army Tracked Vehicles 89 M.T. 197 cu.m.(88 L/T, 174 M/T).

Bargo No. 0006 Army General 2 M.T. 10 cu.m.
(2 L/T, 9 M/T).

A-1-3

2166.EA7/
114pt

NATO UNCLASSIFIED

NATO UNCLASSIFIED

APPENDIX 2 TO
ANNEX A TO
STANAG 2166
 (Edition 3)

VESSEL STOWAGE LOCATION CODES
 (Breakbulk Cargo Only)

The vessel stowage location code is a three-position alpha-numeric code that identifies where breakbulk cargo is stowed on a vessel.

First position: Hatch Number. Will be identified by a numeric code 1 through 8, as appropriate.

Second and third positions: Hold or Deck.

<u>Code</u>	<u>Description</u>	<u>Code</u>	<u>Description</u>
1D*	First deck	ML	Mate Locker
2D*	Second deck	MK	Middle trunk
3d*	Third deck	OD	On deck
AL	Ammo Locker	RD	Orlop deck
CM	Care of mate	PL	Paint Locker
DT	Deep tank	RB	Reefer box (cargo)
FL	Flight deck	SL	Security locker
FD	Forecastle deck	SD	Shelter deck
FT	Forecastle tween deck	SR	Ship's refrigerator
FR	Freeze box or room	ST	Strong room
HD	Hanger deck	TA	Tank deck
LZ	Lanzarette	TD	Tween deck
LH	Lower hold	UD	Upper deck
LR	Lower reefer flat	UR	Upper reefer flat
LK	Lower trunk	UK	Upper trunk
LT	Lower tween deck	UT	Upper tween deck
LV	Lower van flat	UV	Upper van flat
MR	Mailroom	CH	Chill box or room
MD	Main deck	PĐ	Prom deck
MT	Main tween deck		
LM	Mast locker		

* If vessels have lettered decks, use deck letter in second position and letter "D" in third position.

A-2-1

2166.EA8/
114pt

NATO UNCLASSIFIED

NATO UNCLASSIFIED

APPENDIX 3 TO
ANNEX A TO
STANAG 2166
 (Edition 3)

Abbreviations/Acronyms

AUTODIN	:	Automatic Digital Network
CTM	:	Cargo Traffic Message
cu.m.	:	Cubic Metre (1000 cubic decimetres)
e.g.	:	For Example
ETA	:	Estimated Time of Arrival
HL	:	Heavy Lift
IMDG	:	International Maritime Dangerous Goods
IRCS	:	International Radio Call Sign
LASH	:	Lighter Aboard Ship
L/T	:	Long Ton (2,240 pounds)
MILVAN	:	Military-owned demountable container
MS	:	Motor Ship
M.T.	:	Metric tonne (unit of 1000 kilogram)
M/T	:	Measurement Ton (40 cubic feet)
MV	:	Motor Vessel
NEQ	:	Net Explosive Quantity
NS	:	Nuclear Ship
REEFER	:	Refrigerated shipping container
RORO	:	Roll-on/Roll-off
SEABEE	:	Sea-Barge
SEAVAN	:	Commercial or Government-owned (leased) shipping container
SS	:	Steamship
TBN	:	To be Named
TCN	:	Transportation Control Number
USCG	:	United States Coast Guard
USNS	:	United States Naval Ship
USS	:	United States Ship

A-3-1

2166.EA9

NATO UNCLASSIFIED

NATO UNCLASSIFIED

ANNEX B TO
STANAG 2166
(Edition 3)

SAILING SIGNAL - LOAD ADVICE

(Classification)

(SHORT FORMAT)

PRECEDENCE For both action and information this must always be "IMMEDIATE" to ensure arrival in advance of the ship.

FROM Originator (usually the movement authority at the port of loading).

TO Sailing Signals have a wide distribution which varies according to the destination port of the particular movement. Sailing Signals should be sent to the same addressees as the corresponding SEAMOV signals. The following should always be included:
 MOD and Command HQ
 Naval HQ and shipping control authorities
 Dispatching authorities
 Movement authorities at origin and at destination ports
 International coordinating authorities

INFORMATION As appropriate

TEXT:

SAILING SIGNAL - LOAD ADVICE NUMBER

ALPHA Code name of plan or ad hoc movement

BRAVO Ship's name and international number or nickname

CHARLIE Departure port and actual time of departure

DELTA Arrival port and estimated time of arrival

ECHO Either: Plan serials plus or minus, or:
 Specific load details including personnel, numbers of ISO containers, tonnages, and IMDG hazard classes for dangerous goods

FOXTROT Remarks

(Classification)

B-1

2166.EB1/
114pt

NATO UNCLASSIFIED

NATO UNCLASSIFIED

ANNEX C TO
STANAG 2166
(Edition 3)

SEA MOVEMENT RESOURCE SIGNAL
(SEAMOV)

(Classification)

PRECEDENCE In view of the short warning time this will almost invariably be "IMMEDIATE"

FROM Originator

TO SEAMOV resource signals have a wide distribution which varies according to the destination ports of the particular planned or ad hoc movement. The following should always be included:

MOD and Command HQ
Naval HQ and shipping control authorities
Movement authorities at origin and at destination ports
International coordinating authorities

INFORMATION As appropriate

TEXT:

ALPHA Plan code word or 'ad hoc' as appropriate

BRAVO H hour (ETD of first ship in plan)

CHARLIE SEALIFT

ONE Serial

TWO Ship's name, international number or nickname

THREE Port of loading

FOUR Time alongside

FIVE Time of departure

SIX Port of arrival

SEVEN Expected time of arrival

EIGHT Expected time to complete offload

NINE Return port and expected time of arrival

DELTA CARGO (Plan serials of details where known)

(Classification)

C-1

2166.EC1/
114pt

NATO UNCLASSIFIED

NATO UNCLASSIFIED

ANNEX D TO
STANAG 2166
(Edition 3)

CARGO STOWAGE PLAN

Appendix 1 - General Format

PURPOSE

1. The purpose of this document is to provide a diagram of a vessel's cargo space showing the location (both on and below decks) of all cargo. The format of this diagram may be used as required for planning stows and for documenting actual stows.

GENERAL FORMAT

2. See Appendix 1.

INFORMATION SHOWN ON THE CARGO STOWAGE PLAN

3. The hatch location of all cargo will be indicated accurately and in addition, the cargo stowage plan will show:

- a. Items of the cargo to be discharged at each port.
- b. The location of "Heavy Lift" items and awkward/outsize loads.
- c. Capacity and location of ship's booms/derricks.
- d. Special cargo, e.g. mail, attractive/high value items, etc.
- e. Hazardous cargo.

PREPARATION

4. The preparation of the cargo stowage plan should be divided into the following three main parts:

- a. A representation of cargo specifying, for each type, its weight, volume, location (both on and below decks), and destination.
- b. A recapitulation, by hatches of total tonnage for each port of discharge.
- c. Miscellaneous entries, e.g., summaries of heavy lifts, awkward/outside loads, boom/derrick capacities, etc.

5. Cargo stowed in the lower holds will be shown in profile (side view) while that on deck in between decks will be shown in plan (top view).

D-1

2166.ED1/
114pt

NATO UNCLASSIFIED

NATO UNCLASSIFIED

6. The location of cargo for each port of discharge will be shown by the following colour code:

- 1st Port of discharge : solid green
- 2nd Port of discharge : solid red
- 3rd Port of discharge : solid yellow
- 4th Port of discharge : horizontal green stripes
- 5th Port of discharge : vertical red stripes
- 6th Port of discharge : horizontal yellow stripes
- 7th Port of discharge : vertical green stripes
- 8th Port of discharge : horizontal red stripes
- 9th Port of discharge : vertical yellow stripes

NOTE: If the use of a colour code is not practicable, the location of cargo for each port of discharge should be shown by shading, cross-checking, or other suitable means.

7. The volume and weight of each item of cargo will be shown both in measurement tons (1 measurement ton = 40 cubic feet) and long tons (1 long ton = 2240 pounds), or in metric tonnes and cubic metres. In the stowage plan at Appendix 1 to this Annex these details are given in measurement tons and long tons.

CONSOLIDATED STOWAGE PLAN

8. When a vessel is loaded at more than one terminal within a given port, or at more than one port, the shipping authority responsible for the documentation of each loading will forward copies of the cargo stowage plan to each successive loading terminal.

9. It will be the responsibility of the final loading terminal to prepare and distribute the final cargo stowage plan indicating total cargo loaded.

LEGEND of abbreviations used on Stowage Plan (see Appendix 1)

-
- BXS - Boxes
 - C - Packages
 - CR - Crates
 - CT - Cartons
 - CU.M. - Cubic Metre (1000 Cubic Decimetres)
 - PCS - Pieces
 - TRK - Trucks
 - CO - Containers
 - PT - Palletized Unit Loads
 - M.T. - Metric Tonne (Unit of 100 Kilograms)
 - M/T - Measurement Ton
 - L/T - Long Ton
 - TW - Total Weight
 - EA - Each (e.g., 2 EA 2 1/2 T TRK = Two such 2 1/2 ton trucks)

D-2

2166.ED2

NATO UNCLASSIFIED

STOWAGE PLAN (General Format)

SAILED
LOADING PORT AND LOCATION
LOADING STARTED AT
LOADING ENDED AT
LOADED BY

FROM

TO

SAILED

TO

DRAFT-FWD

AFT

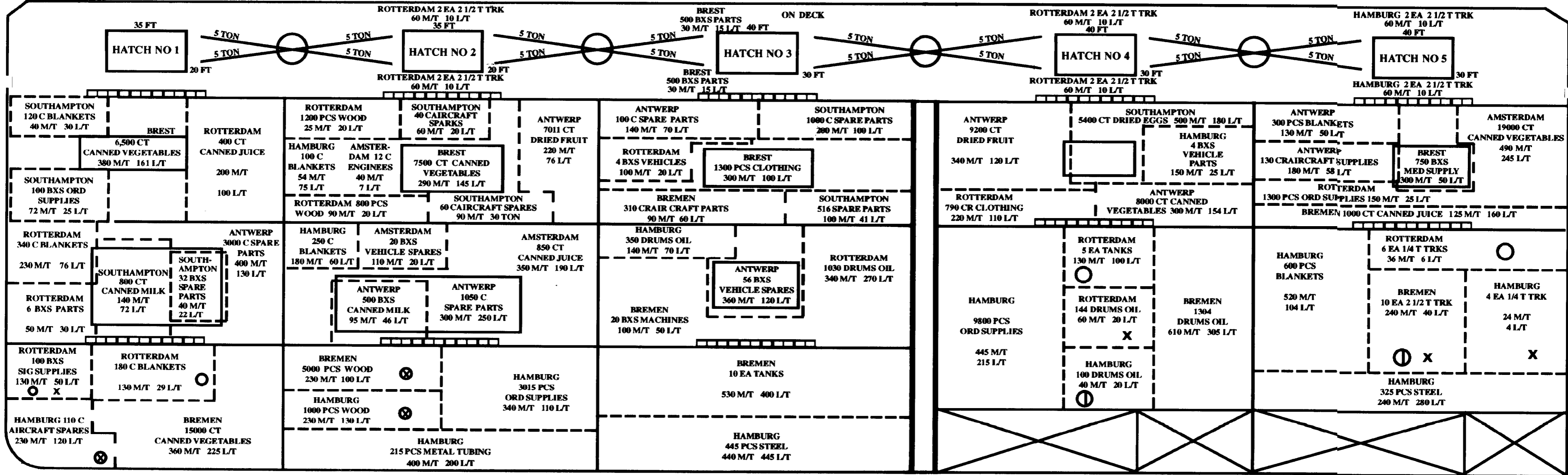

CHIEF MATE

D - 1 - 1

MASTER

APPENDIX B
**EXTRACT OF QSTAG 592:
FORECAST MOVEMENT REQUIREMENTS -
RAIL, ROAD AND
INLAND WATERWAYS**

This appendix includes an extract of QSTAG 592 (Forecast Movements Requirements - Rail, Road, and Inland Waterways). This appendix is implemented by Chapter 5 (Inland Waterway Operations). QSTAG 592 standardizes documents common to several means of transport. This agreement helps the terminal operators predict movement requirements.

DETAILS OF AGREEMENT

FORECAST MOVEMENT REQUIREMENTS -
RAIL, ROAD AND INLAND WATERWAYS

- Annex** : A. Table of Forecast Movement Requirements - Rail, Road and Inland Waterways.
- Related documents** : STANAG 2021 - Computation of Bridge, Raft and Vehicle Classification.
- QSTAG 562 (STANAG 2156) - Surface Transport Request and Reply to Surface Transport Request.
- STANAG 1059 - National Distinguishing Letters for use by NATO Forces.

AIM

1. The aim of this agreement is to standardize for ABCA Forces a document common to several means of transport for the purpose of submitting forecast movement requirements, including movement requirements based on approved contingency plans, to their own national authorities and/or to the nations concerned in such movements.

AGREEMENT

2. Participating nations agree to use the standard format found at Annex A for the "Table of Forecast Movement Requirements - Rail, Road and Inland Waterways".

FORECAST MOVEMENT REQUIREMENTS

3. As soon as military authorities have knowledge of their movement (or transport) requirements, for a given period of time, they are to inform the military authority responsible for the organization of movements (or transport) in the originating nation (or in the originating zone in a nation) as soon as possible.

4. When forwarding the essential information, the requesting authority must use the format of the "Table of Forecast Movement Requirements - Rail, Road and Inland Waterways" shown at Annex A as follows:

- a. Action : To the military authority of the originating nation (or in the originating zone in a nation) in charge of the organization of movements.
- b. Information : To the military authorities concerned of the transiting nation and nation of destination (or the transiting zone and zone of destination in a nation).

QSTAG 592

5. Study of the "Table of Forecast Movement Requirements - Rail, Road and Inland Waterways" will allow the military authority in charge of the organization of movements in the originating nation (or in the originating zone in a nation):

- a. To carry out a preliminary survey on the possibilities of granting the request.
- b. To take the first steps with the military authorities of the transiting nation and nation of destination (or the transiting zone and zone of destination in a nation).
- c. To select the type of transport to be used.
- d. To inform the requesting authority:
 - (1) Of steps taken to satisfy his requests.
 - (2) Of the movements for which it will be necessary for the requesting authority to make out a "Transport Request" in accordance with the provisions of QSTAG 562.
- e. To develop supporting transportation plans for forecast requirements resulting from approved contingency plans.

6. The Forecast Movement Requirements - Rail, Road and Inland Waterways must be forwarded, if possible, in writing. It can also be forwarded by signal or by telephone by using the code identifying the different items and columns. A specimen of the "Forecast Movement Requirements - Rail, Road and Inland Waterways" as transmitted by signal, is enclosed at Appendix 2 to Annex A.

ANNEX A TO QSTAG 592

(1)

TABLE OF FORECAST MOVEMENT REQUIREMENTS-RAIL, ROAD AND INLAND WATERWAYS (Simplified Format)

For the Period of Time from (date) to (2)

FROM (3)

TO (4)
(Requesting Authority)
(Competent Authority of the Originating Nation)

Serial or Line Item	AREA/POINT		Type of transport preferred	PAX Number	Type of cargo or Type	LOADS			SPECIAL LOADS Class 2021 No.	Sketch No.	Date movement to commence	Date movement proposed for commencement	Priorities	Remarks												
	Consig- nore	of depar- ture-coor- dinates				Consig- nore	of depar- ture-coor- dinates	Nations/ National zones concerned							CARGO Weight	Cube	Number of Each									
	ALFA	BRAVO	CHARLIE	DELTA	ECHO	FOXTROT	GOLF	HOTEL	INDIA	JULIET	KILO	LIMA	MIKE	NOVEMBER	OSCAR	PAPA	QUEBEC	ROMEO	SIERRA	TANGO	UNIFORM					
ONE																										
TWO																										
THREE																										
FOUR																										
FIVE																										
SIX																										
SEVEN																										
EIGHT																										
NINE																										
TEN																										

NOTES: For notes and explanation see Appendix I to this Annex.

APPENDIX 1 TO
ANNEX A TO QSTAG 592

NOTES ON TABLE OF FORECAST
MOVEMENT REQUIREMENTS -
RAIL, ROAD AND INLAND WATERWAYS

HEADINGS	MEANING	REMARKS
(1)	Classification	Enter classification of report as determined by originating agency.
(2)	Period of Forecast	Enter period of forecast as announced by the appropriate national authority.
(3)	Requesting Authority	Enter unit designation of organization responsible for submitting, e.g. 97th Signal Group.
(4)	Competent Authority of the Originating Nation	Enter unit designation of organization directed to receive forecast within originating nation.
<u>COLUMN</u>	<u>MEANING</u>	<u>REMARKS</u>
	Serials or Line Items	Use separate serial or line number for each shipment forecast
Alpha	Reference Number or Nickname	
Bravo	Consignor	Enter specific dispatching agency
Charlie	Location and Coordinates	Enter exact location and coordinates (2 letters, 6 figures)
Delta	Consignee	Enter specific receiving agency
Echo	Location and Coordinates	Enter exact location and coordinates (2 letters, 6 figures)
Foxtrot	Nation/National Zones Concerned	Enter National Distinguishing letters (see STANAG 1059)
Golf	Type of Transport Preferred	Enter preferred mode: Road IWT, Rail (see STANAG 2156)

HEADINGS	MEANING	REMARKS
Hotel/India	Number and Type Passenger	Enter number of passengers and general description. Personnel are normally listed as troops, patients, civilians, POWs, and such other categories as will assist the movements personnel in selecting the mode of transportation.
Juliet/Kilo/Lima	Class of Supply and Tonnage	Enter class of supply, estimated tons and cube. <u>Note:</u> (State type of ton used e.g. Metric Ton (MT), Long Ton (LT), Short Ton (ST). The movement programmers are not normally concerned with an inventory of specific items within a class; however, items requiring special handling must be specified in the remarks column so that the outstanding characteristics can be readily identified. For example, heavy lifts other than vehicles should be expressed in units, dimensions, and tons for each lift.
Mike/November/Oscar/Papa	Special Loads	Enter number of vehicles/tanks to be moved weight in tons (see note at Juliet above) for each, military load classification in accordance with STANAG 2021 (Road) and sketch number of the unified contours booklet (Rail).
Quebec	Rate of Dispatch	Enter tons (see note at Juliet above) of cargo or number of vehicles/tanks which can be moved daily (the capacity of the shipping and receiving organization determines).
Romeo	Date Movement to commence	Enter earliest date that movement can commence.
Sierra	Date Movement Preferred/Required for Completion	Enter date movement preferred/required for completion, followed by preferred or required as applicable.

HEADINGS	MEANING	REMARKS
<p>Tango</p> <p>Uniform</p>	<p>Priorities</p> <p>Remarks</p>	<p>Enter assigned priority.</p> <p>Enter any information which will assist in planning the move, e.g. heavy lifts, dangerous material, special handling data on wheeled vehicles, and passenger requirements.</p>

MESSAGE (Specimen)

FROM : HQ/ADVANCED BASE UK
TO : EMG/CM TPT
SUBJECT : TABLE OF FORECAST MOVEMENT REQUIREMENTS - RAIL,
ROAD AND INLAND WATERWAYS FOR PERIOD OF 10 JAN TO
16 JAN 1966

PRECEDENCE : ROUTINE

ONE	ALFA	P/156
	BRAVO	3 REPL BN
	CHARLIE	ZEEBRUGGE ES (6 figures)
	DELTA	9 REPL CO
	ECHO	MUNSTER MC (6 figures)
	FOXTROT	BE/NL/GE
	GOLF	RAIL
	HOTEL	200
	INDIA	TROOPS
	JULIET	BAGGAGE
	KILO	8 MT
	LIMA	400 CU FT
	MIKE	NIL
	NOVEMBER	NIL
	OSCAR	NIL
	PAPA	NIL
	QUEBEC	50 MT PER DAY
	ROMEO	12 JAN
	SIERRA	15 JAN REQUIRED
	TANGO	TWO
	UNIFORM	NIL

TWO	ALFA	S/723
	BRAVO	DEPOT 603
	CHARLIE	ZEEBRUGGE ES (6 figures)
	DELTA	ASP 503
	ECHO	MUNSTER MC (6 figures)
	FOXTROT	BE/NL/GE
	GOLF	RAIL
	HOTEL	NIL
	INDIA	NIL
	JULIET	AMMUNITION
	KILO	5000 MT
	LIMA	1500 CU METRES
	MIKE	NIL
	NOVEMBER	NIL
	OSCAR	NIL
	PAPA	NIL
	QUEBEC	1000 MT/PER DAY
	ROMEO	12 JAN
	SIERRA	16 JAN REQUIRED
	TANGO	TWO
	UNIFORM	NIL
THREE	ALFA	Q/415
	BRAVO	DEPOT 605
	CHARLIE	GEEL FS (6 figures)
	DELTA	SP 505
	ECHO	RHEINDAHLEN LB (6 figures)
	FOXTROT	BE/NL/GE
	GOLF	RAIL
	HOTEL	NIL
	INDIA	NIL
	JULIET	NIL
	KILO	NIL
	LIMA	NIL
	MIKE	10
	NOVEMBER	60 MT
	OSCAR	40
	PAPA	3145
	QUEBEC	2

ROMEO	12 JAN
SIERRA	17 JAN REQUIRED
TANGO	TWO
UNIFORM	HEAVY LIFT REQUIRED AT DESTINATION

APPENDIX C

**EXTRACT OF STANAG 2926
PROCEDURES FOR THE USE AND HANDLING OF
FREIGHT CONTAINERS
FOR MILITARY SUPPLIES**

This appendix includes an extract of STANAG 2926 (Procedures for the Use and Handling of Freight Containers for Military Supplies). This appendix is implemented by Chapter 6 (Marshaling Yard Operations). STANAG 2926 ensures that national containerization procedures are internationally compatible and interoperable. This STANAG also includes factors relating to container selection, handling, inspection, and stuffing.

NATO UNCLASSIFIED

Agreed English/French texts

STANAG 2926
(Edition 1)
NAVY/ARMY/AIR

NATO STANDARDIZATION AGREEMENT
(STANAG)

PROCEDURES FOR THE USE AND HANDLING OF FREIGHT
CONTAINERS FOR MILITARY SUPPLIES

Annexes : A. National Standards for Cargo Restraint
B. ISO Standard Freight Container

Related Documents : STANAG 2828 MH - Military Palletes, Packages and Containers
STANAG 2829 MH - Materials Handling Equipment
ISO 830 - Freight Containers - Terminology

AIM

1. The aim of this agreement is to ensure the compatibility and interoperability of national containeration procedures as they apply to military supplies.

AGREEMENT

2. Participating nations agree to adopt the procedures for the containerization of military supplies as stated herein. Provisions of this STANAG will not be construed as authorizing any compromise of safety standards.

DEFINITIONS

3. The following definitions are used for the purpose of this agreement:

- a. Stuffing. The placing of cargo and cargo bracing material (dunnage) if required, into the container.
- b. Unstuffing (Stripping). The removal of cargo and cargo bracing material (dunnage) from the container.
- c. Load Planning. The plan for stuffing and dunnaging cargo in a container to achieve proper distribution of cargo weight and optimum utilization of the container's weight and cube capacity, and to provide the necessary restraint required to protect the cargo and the container.

NATO UNCLASSIFIED

- d. Mechanical Cargo Restraining System. A reusable cargo restraining system installed in containers.
- e. Tomming. Restraining cargo from upward movement.

GENERAL

- 4. This agreement is intended to supplement national policies when necessary to provide for interoperability amongst member nations.
- 5. Throughout this agreement, dimensions are given in millimetres (mm) and in inches (in) and weights in kilograms (kg) and pounds (lb). These dimensions and weights are considered to be "corresponding values," and not necessarily exactly equivalent.

DETAILS OF THE AGREEMENT6. Container selection

- a. General. The shipper's selection of containers must be based on factors which include, but are not limited to, the following:
 - (1) Physical characteristics of the cargo.
 - (2) Compatibility of the cargo.
 - (3) Destination of the cargo and receiving capabilities at destination.
 - (4) Optimum utilization of container cubic and weight capacities.
 - (5) Availability of containers.
- b. Type of cargo. The type of containers used by the shipper will be determined by the type of cargo to be shipped, such as ammunition and explosives. Special containers such as open top, ventilated, flat rack, controlled temperature, and bulk liquid containers are available in limited quantities for particular commodities.
- c. Cargo volume and density.
 - (1) In the selection of container sizes, shippers will give prime consideration to the cargo volume and density. The weight and cubic capacity of the container should be utilized to the maximum extent possible with a usage factor of not less than 80 percent weight or cube as a goal.

NATO UNCLASSIFIED

- (2) Shippers will ensure that the gross weight of the tractor, chassis, container, and container cargo does not exceed maximum weight limitations of applicable national highway regulations, unless prior approval/authority is obtained, or does not exceed other weight limitations that may be imposed for safety, operational, or technical reasons. In case of open top or flat rack containers, the shipper shall not normally load cargo so that it extends beyond the confines of a similar closed container, that is an enclosed area 243.8 cm (8 feet) wide, and the height and length of the container. Exceptions may be made if the extending portion of the cargo will be within the clearance limitations of the country through which the container will move and if the cargo protrusion will not interfere with the loading and handling of the container.

7. Container handling

- a. Container Movement. Containers are designed to be lifted from the top, using corner fittings and lifting devices designed for this purpose. They should not be lifted with a conventional forklift truck unless they have been provided with fork pockets. Loaded containers should always be lifted by the corner fittings. Failure to comply with this restriction may cause damage to the container and could result in a significant safety hazard.
- b. Container Positioning. When the container is removed from the chassis, it should be positioned on a hard, level surface, free of rocks or other debris which might cause damage to the container. The container may be temporarily placed directly on a paved surface during stuffing and unstuffing operations.
- c. Container Inspection. Shippers will ensure that containers are inspected and in good repair prior to stuffing operations to ensure cargo security, safety of operation, and to preclude cargo damage from exposure to the elements. Inspection of each container will be performed by competent personnel and as a minimum will ensure that:
 - (1) Containers are free from cracks, punctures, or holes which could allow sea spray and water to penetrate the containers and damage the cargo, allow pilferage, or allow the introduction of contraband items.
 - (2) Doors can be sealed properly to prevent entry of moisture and water into the container and may be effectively closed to prevent unauthorized access. The application of seals or locks will be in accordance with national regulations.

NATO UNCLASSIFIED

- (3) Locking devices are intact and in working order; top and bottom rails, floor cross members and corner fittings are not cracked, broken, or deformed; and corner posts are not out of alignment so as to render the container unsafe or incompatible with operating equipment.
- (4) Containers are free of infestation and debris.
- (5) A Container Safety Convention (CSC) inspection plate is attached and that the effective inspection date has not expired.
- (6) Markings required for the identification and tracking of the container are complete and legible.
- (7) When applicable, the mechanism for temperature control is in good working order and can be serviced enroute.

8. Container stuffing

- a. Types of container stuffing. There are several methods for stuffing containers, depending upon the type of cargo to be transported. For the purpose of this STANAG, two generalized categories are utilized:
 - (1) Palletized cargo - container stuffing (Preferred method). Shippers will ensure that the cube/weight capacity of the containers is utilized to the maximum extent possible. The total number of standard 1000mm x 1200mm (40- by 48-inch) palletized loads in prescribed height that may be stuffed within a 6m (20 foot) container, for example, is 20, stacked two tiers high. (See Annex B). Various size containers will be stuffed utilizing the same loading pattern, with the quantity limited by the container size.
 - (2) Unpalletized cargo - container stuffing. A technique in which a container is stuffed with individual items and/or small boxes, and crates until cube/weight capacity of the container is attained. Cargo will be arranged within the container to ensure maximum cube/weight utilization.
- b. Preparation for container stuffing. Shippers will undertake the following precautionary/preparatory actions prior to beginning the actual stuffing of containers:
 - (1) A load plan will be developed, prior to stuffing operations, to achieve maximum cube/weight utilization and to ensure that proper dunnaging (blocking and bracing) is planned for the protection of the cargo, the container, and the loading/unloading personnel.

- 4 -

NATO UNCLASSIFIED

NATO UNCLASSIFIED

- (2) Cautionary action will be taken to support the front end of a container on a chassis not connected to a prime mover, with adequate cribbing or stanchions to prevent nosing over during stuffing operations. When the container/chassis combination is not connected to a prime mover, wheels of the chassis must be blocked.
- c. Procedures for container stuffing. Shippers will ensure that the following procedures, as applicable, are followed when stuffing containers:
 - (1) Items of cargo stuffed into a container must be compatible. For example, cargoes of food or medical supplies will not be mixed in a container with insecticides, packaged POL products, chemicals and compounds, and/or hazardous materials.
 - (2) Stuffing of wet and dry cargo in a container will be avoided whenever possible. If wet and dry cargo is stuffed in the same container, the dry cargo will be placed over the wet, with sufficient intermediate dunnage to prevent liquid damage.
 - (3) Cargo stuffed into a container is to be properly distributed, stowed, and restrained to:
 - (a) prevent cargo from shifting during transit, and falling out when container doors are open at destination;
 - (b) prevent load concentrations in excess of the container design;
 - (c) prevent weight imbalances which are unsafe and which can impair operations and cause overloading of the prime mover axles;
 - (d) prevent damage to cargo caused by forces encountered in shipping via all modes of international transport; and
 - (e) prevent injury to personnel and damage to the container and lading.

High density cargo will be placed on the lower tier and low density cargo on the upper tier to provide a low center of gravity for increased container stability during transport and handling. Cargo will be dunnaged (restrained) to protect it against lateral and longitudinal stresses and movement during transit.

NATO UNCLASSIFIED

- (4) Individual items requiring manhandling will normally not exceed 70 kg (154 pounds). All items in excess of 70 kg (154 pounds) will be palletized or skidded to provide forklift access.
- (5) Wheel loading for forklift trucks used to stuff and unstuff containers should not exceed 19 kg per square centimetre (270 PSI).
- (6) Palletized loads will be stuffed in containers in such a manner as to promote rapid and safe unloading at destination. No cargo or dunnage should bear on container doors. Pallets will not be loaded on their side or in such a manner as to prevent forklift access. Skidded loads will always be stuffed in the container with the skids facing down. Palletized loads will not be forwarded with broken or loose (functionally ineffective) banding. Shipping personnel will ensure that all palletized loads are properly banded, or otherwise restrained, prior to stuffing in containers.
- (7) Palletized unit loads of general cargo on standard NATO 1000mm x 1200mm (40- by 48-inch) pallets for container shipments should not exceed the length and width dimensions of the pallet. Underhang on a pallet should also be avoided and is not acceptable for ammunition unit loads.
- (8) Cargo will be handled in accordance with special precautionary or handling/storage markings, such as, "FRAGILE", "UP/ARROW", "TOP/ARROW", and "THIS SIDE UP".
- (9) Placards and signs necessary for movement of hazardous cargo will be posted on the container exterior in accordance with applicable directives and regulations.
- (10) Required documentation for movement in containers should be placed on the inside of the container at the righthand doorway, readily visible, and accessible to unloading personnel.
- (11) After a container has had the cargo and dunnaging removed, it should be cleaned inside to remove all foreign substances accumulated during movement and be inspected for serviceability. All mechanical components of self-contained restraint systems should be replaced and locked into place. Doors should be tightly closed and secured to preclude damage before it is again moved.

IMPLEMENTATION OF THE AGREEMENT

9. This STANAG is implemented when the necessary orders/instructions have been issued to ensure compliance with the contents of this STANAG.

- 6 -

NATO UNCLASSIFIED

NATO UNCLASSIFIED

ANNEX A TO
STANAG 2926
(Edition 1)

NATIONAL STANDARDS FOR CARGO RESTRAINT

COUNTRY	AMMUNITION		Vertical	Longitudinal	OTHER Lateral	Longitudinal	COMMENT
	Vertical	Lateral					
BE							
CA	2 G*	1 G	2 G	2.5 G	0.6 G	0.4 G	APPLIES TO RAIL AND ROAD MOVEMENT ONLY
DA							
FR							
GE							
GR							
IT							
LU							
NL							
NO							
PO							
TU							
UK	1.5 G	0.75 G	1.5 G	2.5 G	0.75 G	2.5 G	APPLIES TO RAIL AND ROAD MOVEMENT ONLY
US	2 G*	1 G	2 G*	2.5 G	0.6 G	0.4 G	

G: Gravity. In this application, G is a unit of force equal to the force exerted on the load by gravity. For example, a 2G restraint criteria means that the restraint system must contain a 40,000 pound load when subjected to a force of 80,000 pounds.

*Downward direction only, tumbling not required for palletized, skidded, or unitized loads.

A-1

NATO UNCLASSIFIED

NATO UNCLASSIFIED

ANNEX A TO
STANAG 2926
(Edition 1)

ISO STANDARD FREIGHT CONTAINER

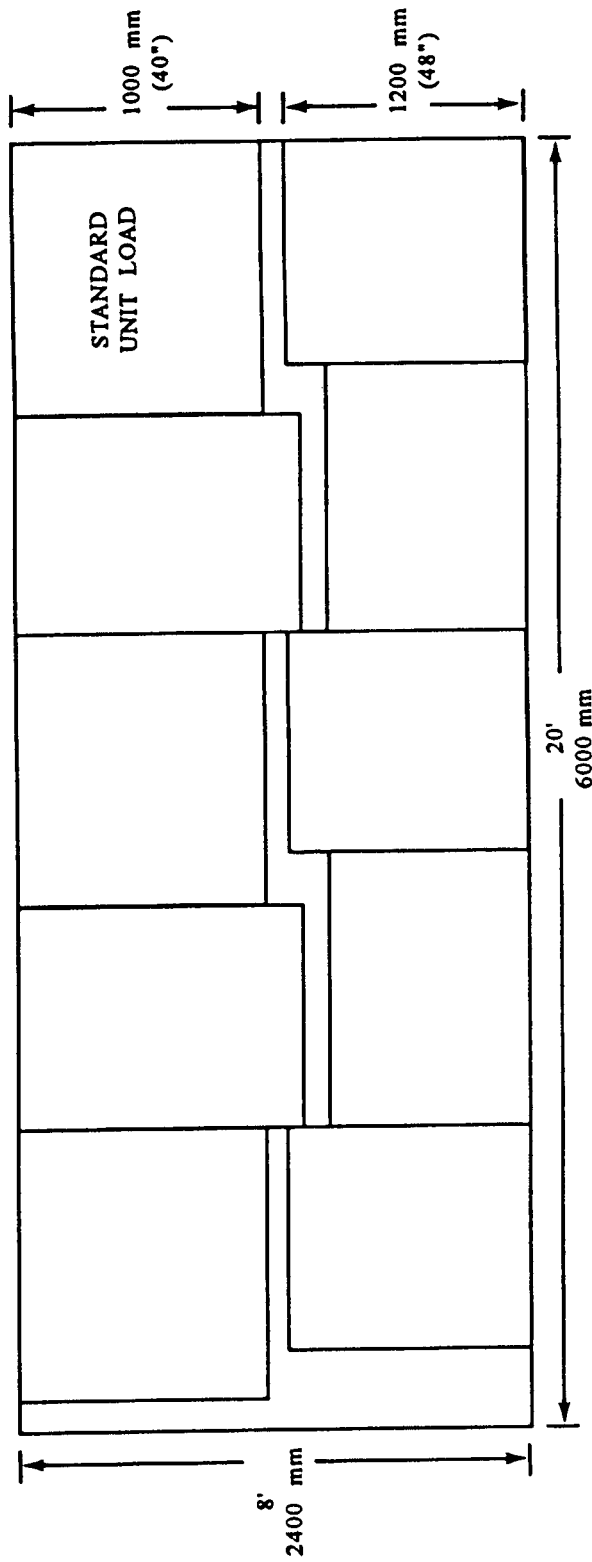

STUFFING PATTERN, STANDARD UNIT LOADS

FIGURE 1

B-1

NATO UNCLASSIFIED

NATO UNCLASSIFIED

STANAG 2926
(Edition 1)

RATIFICATION AND IMPLEMENTATION DETAILS
STADE DE RATIFICATION ET DE MISE EN APPLICATION

N A T I O N	NATIONAL RATIFICATION REFERENCE DE LA RATIFICATION NATIONALE	NATIONAL IMPLEMENTING DOCUMENT NATIONAL DE MISE EN APPLICATION	IMPLEMENTATION/MISE EN APPLICATION							
			FORECAST DATE DATE PREVUE			ACTUAL DATE DATE REELLE				
			NAVY MER	ARMY TERRE	AIR	NAVY MER	ARMY TERRE	AIR		
BE	Does not ratify/ Ne ratifie pas									
CA	2441-2926 (DTRP) of/du 27.5.83	CFTOC-01-060-001/ AX/000;C.09-153-001/TS 000;A-LM-186-001/IS-001; A-ALM-158-004/AG-001;B- GL.303-001 FP-0021/ 003/005				.8.87	8.87	8.87		
DA	M.204.66/S2926/MAS/ARMY 21226 of /du 19.9.83	HRN 717-1				7.84	7.84	7.84		
FR	No. 2026/MMF/BMS of/du 4.9.84									
GE	BMVg-FuS IV 1, Az 03-51-60 of/du 13.2.85	Does not implement/ Ne met pas en application								
GR	069/19/450271/DN 356/HAGS/ DPPD of/du 25.4.84	STANAG 2926								
IT										
LU	Does not ratify/ Ne ratifie pas									
NL	NAS 45.653/43.257/NU of/du 9.5.83	Does not implement/ Ne met pas en application								
NO	MAS/322/83/HST ODRG2/KM/ ABS/STANAG 2926 of/du 14.9.83									
PO	RRN 115/83/DD of/du 29.11.83							2.87	2.87	
TU	MAS/TU ARMY/229/83 of/du 11.7.83	Does not implement/ Ne met pas en application								
UK*	D/COSLOG(Sec)22/6/4 of/du 26.5.83	JSP336, Pamphlet 11				2.88	2.88	2.88		
US	DRCIP-P of/du 12.4.84	AR 55-1 AR 55-16				2.87	2.87	2.87		

*See reservation overleaf/Voir reserves au verso

OTAN SANS CLASSIFICATION

NATO UNCLASSIFIED

RESERVATION

UK: The UK does not regard this STANAG as being applicable to the handling and movement of ammunition and explosives, for which special procedures are required.

RESERVATION

UK: Le Royaume-Uni estime que le present STANAG ne s'applique pas a la manutention et au transport des munitions et explosifs, qui exigent des procedures speciales.

GLOSSARY

- ACV** air-cushion vehicle
- A/DACG** arrival/departure airfield control group
- ADP** automatic data processing
- aid cargo** cargo that is shipped for use by non-US forces
- ALOC** air lines of communication
- AMC** air mobility command
- AO** area of operation
- AOR** area of responsibility
- AR** Army regulation
- arrival/departure airfield control group** Army unit in the joint task force control element receives/releases Army units from/to the Air Force carrier and controls them until released to/from their parent unit or until their operational mission is assured
- ASMP** Army Strategic Mobility Program
- ATTN** attention
- AWR3** Army War Reserve 3
- bare beach operations** as the name implies, the beach is essentially as nature made it. Considerable engineer support is needed to provide a facility suitable for cargo operations. Using amphibians greatly reduces the engineer support required. Bare beach facilities are inefficient and only used when fixed or unimproved facilities are unavailable or inadequate. Since no facilities preexist, the LOTS site location should be near highway and rail facilities. All other capabilities (MHE, hardstand, communications, and support facilities) need to be provided
- BD** Battlefield Distribution
- beach capacity** an estimate expressed in terms of measurement tons, weight tons, or cargo that maybe unloaded over a designated strip of shore per day
- beach transfer points** those locations where cargo is transferred from amphibians for movement to a marshaling yard or to a clearance mode of transportation for delivery to its destination
- break-bulk** cargo other than RO/RO, containerized, or bulk
- CAA** Command Arrangement Agreements
- C&D** consolidation and distribution
- C-E** communications-electronics
- CDI** cargo disposition instructions
- CFR** Code of Federal Regulation
- CHE** container-handling equipment
- C3I** command , control, and communications integration
- CINC** commander in chief
- CINCCENT** Commander in Chief, Central Command
- CIV** civilian
- COL** colonel
- combi-terminal** combination terminal
- COMMZ** communications zone
- CONUS** continental United States
- CORE-OTT** contingency response-ocean terminal teams
- COSCOM** corps support command
- CP** command post
- CPU** central processing unit
- CRT** cathode ray tube
- CSS** combat service support
- CTF** commander, task force

FM 55-60

CWR calm-water ramp
CZ combat zone
DA Department of the Army
DC District of Columbia
DCSLOG deputy chief of staff for logistics
DD Department of Defense
DISCOM division support command
DOD Department of Defense
DS direct support
EAC echelons above corps
ECCM electronic counter-countermeasures
ELCAS elevated causeway
ETA estimated time of arrival
FC floating causeway
fixed-pier discharge operations operations where the vessel is discharged direct to land or land transportation
fixed-port facility a facility designed to accommodate cargo discharge or back-load operations. Characterized by sophisticated equipment and procedures, fixed-port facilities are often oriented toward a specific type of cargo (container, RO/RO, hazardous, and general cargo). However, a recent trend is toward combination facilities. Fixed piers normally have extensive hardstand areas, transit sheds, shore cranes, and access to well-established, well-defined rail and road nets
FM field manual; frequency modulation
FSS fast sealift ship
GS general support
HAZMAT hazardous material
HET heavy equipment transporter
HHC headquarters and headquarters company
HN host nation
HNS host nation support
HQ headquarters
IAW in accordance with

IBS Integrated Booking System
ICODES Improved Computerized Deployment System
inland waterways all navigable inland waterways such as rivers, lakes, inland channels, and canals
intermediate staging area a general locality between the marshaling area and the objective of an airborne or air-landed force. The force or parts thereof pass through it after mounting for refueling, regrouping the aircraft, redistributing personnel and equipment, inspection, and exercises preparatory to an airborne or air-landed assault
ITV in-transit visibility
IWWS inland waterway system
IWWT inland waterway terminal
JCS Joint Chief of Staff
JLOTS joint, logistics over-the-shore
JTF joint task force
LASH lighter aboard ship
LCL less than carload
LCM landing craft, mechanized
LCU landing craft, utility
LN local national
LOA length overall
LOGCAP Logistics Civil Augmentation Program
logistics over-the-shore historically, operations where a vessel anchored in open water was discharged into lighterage; the lighterage was then discharged over a bare beach. This perception is narrow and restrictive. Now LOTS includes any vessel discharge operations other than one conducted at a fixed-pier facility; the vessel is directly discharged to other than land or land transportation. Logically, LOTS includes vessel discharge to lighterage and subsequent discharge over the shore. Neither the type of beach nor the vessel anchorage plays any part in defining LOTS
LOGMARS logistics application of marking and reading symbols
LOTS logistics over-the-shore

LRC lesser regional contingency	ORP ocean reception point
LST landing ship, tank	Pam pamphlet
LTC lieutenant colonel	Panamax those vessels that can transit the Panama Canal because of length, width, and draft
MAJ major	PCCP port cargo clearance plan
marshaling yard area in which units are reorganized; vehicles and equipment are prepared for departure	PERSCOM personnel command
MCA movement control agency	POL petroleum, oils, and lubricants
MCC movement control center	port and beach clearance clearing of cargo from a water terminal and the beach on which it is located
MCO movement control officer	PREPO prepositioned afloat
MCT movement control team	PSC port security company
METT-T mission, enemy, terrain, troop, and time available	Pub publication
MHE materials-handling equipment	QM quartermaster
MIL military	QSTAG quadripartite standardization agreement
MILSTAMP Military Standard Transportation and Movement Procedures	RAOC rear area operation center
MILVAN military-owned remountable container	RC reserve component
MLW mean low water	roll-on/roll-off vessel vessel designed with stern and/or side ramps and internal ramps to permit the loading and off-loading of self-propelled vehicles
MMC materiel management center	RO/RO roll-on/roll-off
MP military police	RRF ready reserve force
MSC Military Sealift Command	RTOC rear tactical operations center
MSG master sergeant	S3 operational training officer (US Army)
MSR main supply route	SEAVAN commercial- or government-owned (or leased) shipping container
MTMC Military Traffic Management Command	SEABEE sea-going
MTON measurement ton	SFC sergeant first class
NAVORD-OP Navy Ordnance-Ordnance Pamphlet	short ton unit of weight equal to 2,000 pounds
NBC nuclear, biological, chemical	SOFA Status of Forces Agreement
NCOIC noncommissioned officer in charge	SOP standing operating procedure
NEW net explosive weight	SPOD sea port of debarkation
No number	SPOE sea port of embarkation
OCCA ocean cargo clearance authority	SSN social security number
OCONUS outside continental United States	STANAG standardization agreement
OPCON operational control	STON short ton
OPLAN operations plan	

FM 55-60

TA theater Army

TAACOM theater Army area command

TACS Navy auxiliary crane ships

TAMCA theater Army movement control agency

TAV total asset visibility

TCDF temporary container discharge facility

TCMD transportation control and movement document

TCN transportation control number

terminal any facility, regardless of size or complexity, where cargo and personnel are loaded, unloaded, and handled in-transit between various transportation modes. Terminals are established at beginning and destination points for cargo being carried and at in-transit points

TEU twenty-foot equivalent unit

TM technical manual

TO theater of operations

TOE table(s) of organization and equipment

TPFDD time-phased force and deployment data

TRADOC United States Army Training and Doctrine Command

TRANSCOM transportation command

unimproved facility a fixed facility not specifically designed for cargo operations. An example of this type of facility is a pier facility used by fishing vessels. It has a hardstand or hard surface beside a shallow body of water and perhaps some type of simple shore crane to load and discharge fishing boats. The facility is characterized by a lack of sophisticated facilities and equipment. Water depth and pier length are inadequate for oceangoing vessels. Road nets are sparse and rail probably nonexistent. Existing facilities may be adapted for use in cargo operations, but MHE, transit sheds, marshaling area, and communications must be provided to support operations

US United States (of America)

USTRANSCOM United States Army transportation command

VA Virginia

WPS worldwide port system

REFERENCES

SOURCES USED

These are the sources quoted or paraphrased in this publication.

- AR 40-12.** *Quarantine Regulations of the Armed Forces.* 24 January 1992.
- AR 55-38/NAVSUPINST 4610.33C/AFR 75-18/MCO P4610.19D/DLAR 4500.15.** *Reporting of Transportation Discrepancies in Shipments.* 31 August 1992.
- AR 55-228.** *Transportation by Water of Explosives and Hazardous Cargo.* 30 April 1969.
- AR 220-1.** *Unit Status Reporting.* 31 July 1993.
- AR 310-25.** *Dictionary of United States Army Terms (Short Title: AD).* 15 October 1983.
- AR 700-65.** *Nuclear Weapons and Nuclear Weapons Materiel.* 29 August 1985.
- AR 725-50.** *Requisition and Issue of Supplies and Equipment; Requisitioning, Receipt, and Issue System.* 26 January 1993.
- CFR 49.** *Transportation.* 1 October 1993.
- DA Form 12-11-E.** *Subscription Numbers, Part V (FMs, MQSs, STPs, and TCs).* March 1988.
- DA Form 2028.** *Recommended Changes to Publications and Blank Forms.* February 1974.
- DD Form 1384.** *Transportation Control and Movement Document.* April 1966.
- DOD Regulation 4500.32-R, Volume I.** *Military Standard Transportation and Movement Procedures.* 15 March 1987.
- DOD Regulation 4500.32-R, Volume II.** *Military Standard Transportation and Movement Procedures (MILSTAMP): Transportation Account Codes (TACS).* 15 February 1987.
- FM 3-5.** *NBC Decontamination.* 17 November 1993.
- FM 8-285/AFM 160-12/NAVMED P-5041.** *Treatment of Chemical Agent Casualties and Conventional Military Chemical Injuries.* 28 February 1990.
- FM 19-4.** *Military Police Battlefield Circulation Control, Area Security, and Enemy Prisoner of War Operations.* 7 May 1993.
- FM 19-30.** *Physical Security.* 1 March 1979.
- FM 55-12/AFM 76-6/FMFM 4-6/OPNAVINST 4630.27A.** *Movement of Units in Air Force Aircraft.* 10 November 1989.
- FM 55-17.** *Terminal Operations Coordinator's Handbook.* 9 September 1990.
- FM 55-20.** *Army Rail Transport Units and Operations.* 31 October 1986.
- FM 55-30.** *Army Motor Transport Units and Operations.* 14 March 1980.
- FM 55-50.** *Army Water Transport Operations.* 30 September 1993.
- FM 90-23/TACP 5049/USAFEP 5049/PAC 5049/AACP 5049.** *(Rear Security Operations) Army - Tactical Air Forces Procedures for Rear Security Operations at Echelons Above Corps.* 14 November 1989.
- FM 100-15.** *Corps Operation.* 13 September 1989.
- FM 101-10-1/1.** *Staff Officers Field Manual - Organizational, Technical, and Logistical Data (Volume 1).* 7 October 1987.
- FM 101-10-1/2.** *Staff Officers Field Manual - Organizational, Technical, and Logistical Data, Planning Factors (Volume 2).* 7 October 1987.
- FM 101-40/NWP 36(D)/AFR 355-5 /FMFM 11-6.** *Armed Forces Doctrine for Chemical and Biological Weapon Defense.* 30 June 1976.

FM 55-60

JCS Pub 4-01.6. *Joint Tactics, Techniques, and Procedures for Joint Logistics Over-the-Shore (JLOTS).* 22 August 1991.

NAVORD-OP 5. *Ammunition and Explosives Ashore Safety Regulations for Handling, Storing, Production, Renovation, and Shipping.* 1 August 1990.

QSTAG 590. *Marking of Military Cargo for International Movement by All International Means of Support.* 2 May 1983.

QSTAG 592. *Forecast Movement Requirements, Rail, Road, and Inland Waterways.* 21 December 1979.

STANAG 2166. *Movements and Transport Documents Used for Movement by Ship.* 31 March 1988.

STANAG 2926. *Procedures for the Use and Handling of Freight Containers for Military Supplies.* 17 February 1987.

TM 3-250. *Storage, Shipment, Handling, and Disposal of Chemical Agents and Hazardous Chemicals.* 7 March 1969.

TM 9-1300-206. *Ammunition and Explosives Standards.* 30 August 1973.

DOCUMENTS NEEDED

These documents must be available to the intended users of this publication. These sources were also used to develop this publication.

AR 200-1. *Environmental Protection and Enhancement.* 23 April 1990.

AR 200-2. *Environmental Effects of Army Actions.* 23 December 1988.

AR 310-50. *Authorized Abbreviations and Brevity Codes.* 15 November 1985.

CFR 40. *Protection of Environment.* 1 October 1993.

DA Pamphlet 25-30. *Consolidated Index of Army Publications and Blank Forms.* 1 October 1994.

FM 55-15. *Transportation Reference Data.* 9 June 1986.

INDEX

- Air terminals, 7-3 and 7-4
- Ammunition and hazardous cargo, 3-7 and 3-8

- Bare beach facilities, 1-2
- Beach capacity, 4-6 through 4-8
- Beach management, 4-9
- Beach transfer points, 4-8
- Block stacking, 6-6, 6-8

- Capacity
 - IWWS, 5-6
 - IWWT, 5-3
 - terminal throughput, 3-8 and 3-9
- Cargo clearance, 3-13 and 3-14
- Cargo disposition instructions, 6-14
- Classification of terminals by cargo type, 1-3
- Classified cargo, 3-7
- Cluster plans
 - frontloader turret stacking of 20-foot containers (50-foot working aisles), 6-15
 - frontloader turret stacking of 35-foot containers (60-foot working aisles), 6-16
 - frontloader turret stacking of 40-foot containers (70-foot working aisles), 6-17
 - sideloader turret, 6-20
 - sideloader turret stacking of 20-foot containers (15-foot working aisles), 6-18
 - sideloader turret stacking of 35-foot containers (15-foot working aisles), 6-19
 - 20-foot container, 6-21
- Combi-terminals, 1-4
- Command organizations
 - TA, 1-5
 - transportation, 1-5
- Communications, 3-19
- Computing container space requirements, 6-29 through 6-31
- Computing space requirements, 6-12, 6-15 through 6-21

- Container marshaling area, 6-5
- Container marshaling yard, suggested organization, 6-3
- Container-on-chassis marshaling system, 6-9, 6-11
- Container terminals, 1-3 and 1-4
- Containers
 - computing space requirements, 6-6, 6-12 through 6-14
 - stacking configurations, 6-6 through 6-10

- Daily operations report, 3-17
- Direct pierside discharge, 1-2
- Discharge
 - break-bulk berth, 3-10
 - developed fixed container terminal, 3-10
 - lighters berth, 3-10
 - RO/RO berth, 3-10
 - underdeveloped container berth, 3-10
- Discharge capacity worksheet, 3-11
- Documentation
 - automated cargo, 7-6
 - daily operations report, 3-17
 - DD Form 1384, 3-15 through 3-17
 - manual cargo, 7-6

- Fixed-port facilities, 1-2
- Fixed-port and semifixed ports, 6-5 and 6-6
- Fixed-port container transfer facility, example organization and traffic flow, 6-4
- Floating craft maintenance, 3-17 and 3-18

- General cargo terminals, 1-3

- Import cargo, 6-9
- Inbound movements, 3-16
- Inland terminal operations
 - air terminals, 7-3 and 7-4
 - documentation, 7-6
 - inland waterway terminals, 7-5

- motor transport terminals, 7-4 and 7-5
- operational planning, 7-2 and 7-3
- personnel and equipment requirements, 7-3
- personnel movements, 3-18 and 3-19, 7-6
- rail terminals, 7-5
- staff and unit planning, 7-2
- Inland terminals, 1-2 and 1-3
- Inland waterway operations
 - IWWS, 5-1 and 5-2
 - IWWT, 5-2
 - operational planning, 5-2 and 5-3
- Inland waterway organization, 5-2
- Inland waterway system, 5-1 and 5-2
- Inland waterway terminal, 5-2, 7-5
- IWWS capacity, 5-6
- IWWT capacity, 5-3

- LOTS operations
 - beach capacity, 4-6 through 4-8
 - beach management, 4-9 and 4-10
 - beach transfer points, 4-8
 - operation planning, 4-1 through 4-4
 - reconnaissance and site selection, 4-4 through 4-6
 - shore-to-shore operations, 4-10
 - temporary holding areas, 4-8 and 4-9
 - traffic control, 4-9
 - unimproved facility or bare beach, 6-5
 - unloading operations, 4-10
- LOTS terminals, 6-6

- Management and operation of strategic, common-user contingency seaports, 3-2
- Marine maintenance system, 3-17 and 3-18
- Marine terminal operations
 - operational planning, 3-7
 - planning considerations, 3-6 and 3-7
 - planning phases, 3-1
 - planning steps, 3-6
- Marine terminal units
 - organization, 2-1 and 2-2
 - transportation cargo transfer company, 2-6 and 2-7
 - transportation terminal service company (break-bulk), 2-4 through 2-6
 - transportation terminal service company (container/break-bulk), 2-2 through 2-4
 - transportation terminal service detachment, 2-7 and 2-8

- Marine terminals
 - bare beach facilities, 1-2
 - fixed-port facilities, 1-2
 - unimproved facilities, 1-2
- Marshaling area
 - clearance operations, 6-13
 - hypothetical, 6-23
 - suggested design for a security storage area, 6-25
 - suggested traffic flow in fixed terminal, 6-24
 - traffic pattern in on chassis, 6-22
- Marshaling yard operations
 - fixed and semifixed ports, 6-5 and 6-6
 - location of the container marshaling area, 6-5 and 6-6
 - LOTS terminal (unimproved facility/bare beach operations), 6-6
 - organization and functions, 6-2 through 6-5
 - procedures, 6-13 and 6-14
 - rail movement, 6-13, 6-26
 - security, 6-27 through 6-29
 - space requirements, 6-12
 - stacking configurations, 6-6 through 6-10
 - surface requirements, 6-5
 - terminal activities, 6-12 and 6-13
- Motor transport terminals, 7-4 and 7-5
- Movements
 - inbound, 3-16
 - outbound, 3-16 and 3-17
 - personnel, 3-18 and 3-19
 - rail, 6-13, 6-26
 - retrograde, 6-14
- MTMC port management cell, 3-5

- Nonbulk terminals, dry cargo, types of, 3-8

- Ocean reception point, 5-6
- Operational planning, 3-7
- Operations
 - back-load, 6-12 and 6-13
 - off-load, 6-12 and 6-13
- Outbound movements, 3-16 and 3-17

- Patient evacuations, 7-6
- Perimeter security, 6-28
- Personnel and equipment requirements, 7-3

- Personnel movement
 - inbound (debarcation), 3-18 and 3-19
 - intraterminal unit moves, 7-6
 - outbound (embarkation), 3-19
 - patient evacuations, 7-6
 - prisoners of war, refugees, and displaced persons, 7-6
- Planning considerations
 - cargo, 3-7
 - countering the threat, 3-6
 - personnel and equipment requirements, 3-7
 - port security, 3-6 and 3-7
 - theater geophysical characteristics, 3-7
- Planning phases
 - initial phase, 3-2
 - sustained resupply phase, 3-2
 - tactical resupply phase, 3-2
- Productivity, 3-13
- Rail terminals, 7-6 and 7-7
- Reconnaissance
 - aerial, 4-2
 - completion, 4-4
 - ground and water, 4-2 and 4-3
 - initial, 4-1
 - map, 4-2
 - personnel, 4-3 and 4-4
 - site selection, 4-2
- Retrograde
 - cargo, 6-2
 - containers, 6-10
 - movement, 6-10
- Ribbon stacking, 6-5 and 6-6, 6-15
- RO/RO terminals, 1-4
- Security, 6-10 and 6-12
- Semifixed port
 - construction, 6-4
 - surface requirements, 6-3
- Ship destination meeting, 3-11
- Shore-to-shore operations, 4-9
- Special operations, 1-4
- Stacking
 - areas, 6-7
 - block, 6-5 and 6-6, 6-15
 - configurations, 6-5 and 6-6
 - location, 6-9
 - ribbon, 6-5 and 6-6, 6-15
 - turret, 6-5 and 6-6, 6-15 and 6-16
- Stacking configurations
 - off chassis, 6-5 and 6-6
 - on chassis, 6-5 and 6-6, 6-16 and 6-17
- Surface requirements
 - fixed and semifixed ports, 6-5
 - LOTS operations (unimproved facility or bare beach), 6-5
- Sustained resupply phase, 3-2
- Tactical resupply phase, 3-2
- TCMD, 3-15, through 6-12, 7-8
- Temporary holding areas, 4-8 and 4-9
- Temporary in-transit storage areas, 4-7, 7-3
- Terminal activities, 6-7
- Terminal throughput capacity estimation checklist, 3-9
- Terminal clearance capacity, 3-10
- Terminal discharge capacity, 3-9 and 3-10
- Terminal operations
 - inland, 1-2 and 1-3
 - marine, 1-2
- Terminal planning, 7-2 through 7-5
- Terminal throughput capacity estimation, five functional areas
 - clearance, 3-10
 - discharge, 3-9 and 3-10
 - reception, 3-8
 - storage, 3-10
 - transfer, 3-10
- Terminal activities, 6-12
- Terminal capacity
 - clearance, 3-10
 - discharge, 3-9
 - reception, 3-8
 - storage, 3-10
 - throughput, 3-10
 - transfer, 3-10
- Terminal discharge capacity, 3-9
- Terminal planning, 7-2 through 7-5
- Terminal throughput capacity estimation checklist, 3-9
- Terminals
 - air, 7-3 and 7-4
 - classification, by cargo type, 1-3
 - combi-terminal, 1-4

FM 55-60

container, 1-3 and 1-4
general cargo, 1-3
inland, 1-2 and 1-3
inland waterway, 5-2, 7-5 and 7-6
LOTS, 6-5
marine, 1-2
motor transport, 7-4 and 7-5
nonbulk, dry cargo, 3-8
rail, 7-5
RO/RO, 1-4
types of, 1-1 through 1-3
Traffic control, 4-9
Transportation cargo transfer company, 2-6 and 2-7
Transportation composite group, 1-5 and 1-6
Transportation terminal battalion, 1-6 and 1-7
Transportation terminal service company (break-bulk),
2-4 through 2-6
Transportation terminal service company (container/
break-bulk), 2-2 through 2-4
Transportation terminal service detachment, 2-7 and
2-8
Turret stacking, 6-5 and 6-6, 6-15 and 6-16
Types of terminals, 1-1 through 1-3
Unimproved facility operations, 6-5
Unimproved port facilities, 1-2
Unloading operations, 4-10
Vessel loading, 3-14
Vessel unloading, 3-12 and 3-13

FM 55-60
15 APRIL 1996

By Order of the Secretary of the Army:

Official:



JOEL B. HUDSON

*Acting Administrative Assistant to the
Secretary of the Army*
01494

DENNIS J. REIMER
*General, United States Army
Chief of Staff*

DISTRIBUTION:

Active Army, USAR, and ARNG: To be distributed in accordance with DA Form 12-11E, requirements for FM 55-60, *Army Terminal Operations* (Qty rqr block no. 0398)

PIN: 021682-000